

Vaney-Shinde Residence

OWNERS:
Pashmi Vaney & Rahul Shinde
4207 W. Mercer Way, Mercer Island, WA 98040

PROJECT ADDRESS:
4207 W. Mercer Way
Mercer Island, WA 98040

TAX PARCEL NUMBER:
936570-0163

LEGAL DESCRIPTION:
THE WEST 82 FEET OF THAT PORTION OF TRACT 13 IN HARRY WHITE'S PLAT OF EAST SEATTLE ACRE TRACTS, AS PER PLAT RECORDED IN VOLUME 3 OF PLATS, PAGE 36, RECORDS OF KING COUNTY, LYING SOUTHERLY OF WEST MERCER WAY RIGHT-OF-WAY; TOGETHER WITH THAT PORTION OF THE EAST 1/2 OF VACATED SECOND STREET ADJOINING ON THE WEST; SITUATE IN THE CITY OF MERCER ISLAND, COUNTY OF KING, STATE OF WASHINGTON

PERMIT NUMBER:
2006-006
2008-191 - Foundation Permit

PROJECT DESCRIPTION:
Demolish existing residence and existing impervious surfaces. Build new single family residence and related site work.

GOVERNING AUTHORITY:
City of Mercer Island, Development Services Group.

ZONING CODE INFORMATION:
Zone: R 15
Lot Coverage Calculations: A1.0
ABE Calculations: A1.0
Lot Slope Calculation: A1.0
Allowed GFA: 40% x 26,673sf = 10,669sf
Proposed GFA: 3838sf (14.4% of lot area) see Shts. A2.1, A2.2 for GFA detail.

BUILDING CODE INFORMATION:
Building Code: IRC 2015
Occupancy: Group R-3 - Single Family Residence & Group U Garage
Construction Type: V - Wood Frame (VB)
Sprinkled: Per IRC2015 AV107.1 and City of Mercer Island Fire Marshall - NFPA 13D

ENERGY CODE INFORMATION: 2015 WSEC & IRC VENTILATION
Energy Conservation: Component Performance see attached calculations & sheets: A2.1, A2.2, A2.3, A3.1, A3.2, A4.1, A5.1, A9.1, E2.1, E2.2
Energy Credits - 3.5: See this sheet for detailed description of each credit.
1a - Efficient Building Envelope (shts. A3.1, A3.2, A4.1, A5.1, A9.1) .5 credit
2a - Air Leakage Control and Efficient Ventilation (shts. E2.1, E2.2) .5 credit
3a - High Efficient HVAC Equipment (sht. A2.1) 1 credit;
4 - High Efficiency Distribution System: (sht. A2.1, A2.2) A4.1, A5.1) 1 credit
4a - High Efficiency Water Heating (shts. A2.1, A2.2) 1 credit;
Whole House Ventilation: Prescriptive Intermittent Whole House Ventilation Integrated with a Forced Air System per IRC M1507.3.5 with a Whole-House Ventilation Rate of 150 cfm each of (2) fans (see sheets A2.1, A2.2, E2.1 & E2.2).

PROJECT DIRECTORY:

Architect:	Studio Ectypos Contact: Lucia Pirzio-Biroli, Architect 4212 W. Mercer Way Mercer Island, WA 98040 Phone: (206) 232-9147 Fax: (206) 275-0312
Surveyor:	Terrane (formerly Geo-Dimensions) Contact: Ken Green 10801 Main Street, Ste. 102 Bellevue, WA 98004 Phone: (425) 458-4488
Geotechnical Engineer:	Geotech Consultants, Inc. Contact: Marc McGinnes 2401 10th Ave. E. Seattle, WA 98199 Phone: (425) 747-5618
Civil Engineer	WR Consulting Contact: John W. Rundall 820 John St. Seattle, WA 98109 Phone: (206) 264-7784 (x 202) Fax: (206) 264-7769
Structural Engineer:	Byknonen Carter Quinn Contact: Nick Carter 2033 6th Ave, Suite 995 Seattle, WA 98121 Phone: (206) 264-7784
General Contractor:	Mercer Builders Contact: Thomas M. Schultz 3860 76th Ave SE Mercer Island, WA 98040 Phone: (206) 275-1234

DOCUMENT LIST :

Permit Application
Intake Screening
City of Mercer Island Coversheet

Drawing schedule:

A0.1	Cover Sheet / Project Information
----	Site Survey
A1.0	Site Plan, Critical Area Plan and Site Calculations
A1.1	Construction Site Plan
A1.2	Original and Final Grading Plans
C1	General Notes
C2	TESC Plan and Details
C3	Drainage Plan
C4	Detention Tank Details
C5	Drainage Details
C6	Water Course Buffer Restoration
A2.1	Main Floor Plan
A2.2	Upper Floor Plan
A2.3	Roof Plan
A3.1	Elevations
A3.2	Elevations
A4.1	Building Sections
A5.1	Wall Section
A9.1	Window & Exterior Door Schedule
A9.2	Interior Door Schedule
E2.1	Main Floor Electrical Plan
E2.2	Upper Floor Electrical Plan
S0.1	Structural General Notes
S2.0	Foundation Plan
S2.1	Main Floor Framing Plan
S2.2	Upper Floor Framing
S2.3	Roof Framing
S5.1	Structural Details
S5.2	Structural Details
S5.3	Structural Details
S5.4	Structural Details
S5.5	Structural Details

Reports, Memos and City Forms:
Geotechnical Report and project memo
Arborist Report and tree inventory/replacement form
Civil Drainage Memo
Critical Areas Sequencing: Memo (Studio Ectypos);
Critical Areas Compliance and Mitigation Plan; Geotech Memo; Small Project Storm Water Site Plan/Report
Structural Calculations + Supplemental Calculations
Site Development Worksheet - revised
2015 WSEC & IRC Ventilation Worksheet
Fire Gross Square Footage
Water Meter Sizing Worksheet

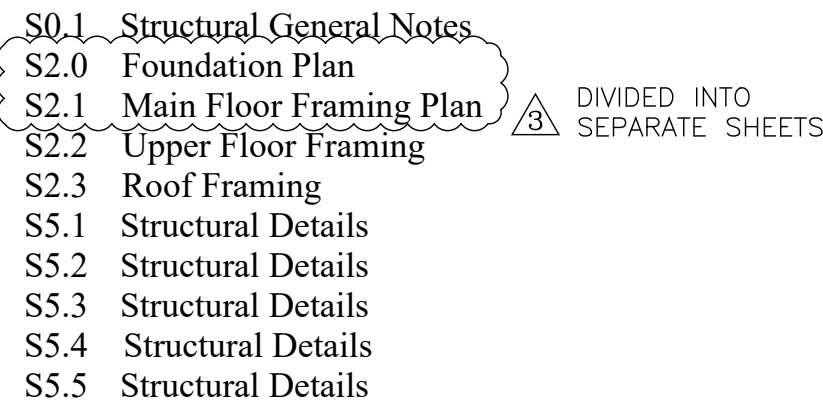

Energy Credit Description
1a - Efficient Building Envelope: Vertical fenestration U=0.28, Floor R=38, Slab on grade R=10 perimeter and under entire slab.
2a - Air Leakage Control and Efficient Ventilation: Compliance based on (WSEC 2015) R402.4.1.2: Reduce the tested air leakage to 3.0 air changes per hour maximum AND all whole house ventilation requirements as determined by Section M1507.3 of the IRC shall be met with a high efficiency fan (max. 0.35 watts/cfm), not interlocked with the furnace fan. Ventilation systems using a furnace including an ECM motor are allowed, provided that they are controlled to operate at low speed in ventilation only mode.
3a - High Efficiency HVAC Equipment: Gas, propane or oil-fired furnace with minimum AFUE of 94%, or Gas, propane or oil-fired boiler with minimum AFUE of 92%.
4 - High Efficiency HVAC Distribution System: All heating and cooling system components installed inside the conditioned space. This includes all equipment and distribution system components such as forced air ducts, hydronic piping, hydronic floor heating loop, convectors and radiators. All combustion equipment shall be direct vent or sealed combustion. For forced air ducts: A maximum of 10 linear feet of return ducts and 5 linear feet of supply ducts may be located outside the conditioned space. All metallic ducts located outside the conditioned space must be insulated to a minimum of R-8. Locating system components in conditioned crawl spaces is not permitted under this option. Electric resistance heat and ductless heat pumps are not permitted under this option. Direct combustion heating equipment with AFUE less than 80% is not permitted under this option.
5a - Efficient Water Heating: All showerhead and kitchen sink faucets installed in the house shall be rated at 1.75 GPM or less. All other lavatory faucets shall be rated at 1.0 GPM or less. Plumbing Fixtures Flow Ratings: Low flow plumbing fixture (water closets) and fittings (faucets and showerheads) shall comply with the following requirements:
1. Residential bathroom lavatory sink faucets: Maximum flow rate - 1.0 gal/min when tested in accordance with ASME A112.18.1/CSA B125.1
2. Residential kitchen faucets: Maximum flow rate - 1.75 gal/min when tested in accordance with ASME A112.18.1/CSA B125.1
3. Residential showerheads: Maximum flow rate - 1.75 gal/min when tested in accordance with ASME A112.18.1/CSA B125.1

VICINITY MAP



GENERAL NOTES:

(See specifications for supplemental information to the General Notes)

- Contractor shall verify all dimensions and conditions shown on drawings at the job site and shall notify the Architect of any omissions, discrepancies and/or conflicts before proceeding with the work.
- General Contractor to coordinate pre-construction site meeting w/ Owner, Architect, Structural Engineer and City of Mercer Island Building Inspector.
- Plumbing, mechanical and electrical work shall be under separate permits according to prevailing codes. Contractor shall obtain such permits.
- Special inspection that are required by the City of Mercer Island Development Services shall be coordinated by Contractor.
- Contractor shall verify existing grade conditions and height limits with Architect and surveyor on site prior to beginning work and shall notify Architect of any discrepancy in the site survey.
- Do not scale drawings, dimensions govern. Large scale dimensions govern over small scale dimensions. Notify Architect of discrepancies in dimensions prior to proceeding with work.
- Construction dimensions shown are to face of sheathing (FOS) on exterior walls, and top of (T.O.) slab at doors or sub-floor at floor levels.
- SPRINKLERS** An approved automatic fire sprinkler system shall be installed per IRC 2015 AV107.1
- DWELLING/GARAGE SEPARATION** shall meet the requirements of IRC R302.6. All habitable rooms shall be separated on the garage side by not less than 1/2" Type "X" gwb or equivalent.
DWELLING/GARAGE OPENING/PENETRATION PROTECTION shall meet the requirements of IRC R302.6.1-R302.6.3. Doors shall be minimum 20 minute fire rated doors equipped with a self-closing device.
- SMOKE DETECTION** shall meet the requirements of IRC R314. All smoke alarms shall be listed and labeled in accordance with UL217 and shall meet the provisions of NFPA 72. Smoke alarms shall be located as follows: each sleeping room; outside each separate sleeping area in the immediate vicinity of the bedrooms; on each floor of the dwelling.
- CARBON MONOXIDE ALARMS** shall meet the requirements of IRC R315. Carbon monoxide alarms shall be installed outside each separate sleeping area in the immediate vicinity of the bedrooms, on each floor level of the dwelling.
- EMERGENCY EGRESS WINDOWS** shall meet the requirements of IRC R310. Each sleeping room shall have an operable rescue opening. The sill height shall not be more than 44" from the finished floor to the bottom of the opening. Minimum net clear opening shall be 5.7 square feet; minimum clear width 20"; minimum clear height 24".
- STAIRWAYS** shall meet the requirements of IRC R311.7. Stairways shall have a minimum clear width of 36" above handrail, and be not less than 31 1/2" in width below handrail. Minimum headroom shall not be less than 6'-8". Maximum riser 7 3/4" / minimum tread 10". Handrails shall be not less than 34" or more than 38" above the slope of the plane of the stairs and shall be continuous for the full run of the flight and shall have a minimum space of 1 1/2" between wall and railing.
- FIREPLACES AND FLUES**
Factory built fireplaces shall meet the requirements of IRC R1004. Shall be listed and labeled and shall be installed in the accordance of the listing.
Factory built chimneys shall meet the requirements of IRC R1005. Shall be listed and labeled and shall be installed in the accordance of the listing.
- Provide fireblocking according to IRC R302.11 where applicable.
- See specifications for required shop drawings. Contractor shall prepare and submit shop drawings to governing authority.
- Provide mounting blocks at exterior walls behind all light fixtures, hosebibs, structural steel connectors, guardrails and any other exterior mounted accessories. Verify type of mounting block with Architect prior to installation.
- Provide dampproofing on all below grade foundation walls per IRC R406. Provide all accessories required for a completely watertight installation, including but not necessarily limited to: flashing, counterflashing, sealant, and caulking at all roof and wall penetrations; interlocking weatherstripping at all doors and windows; waterstops and other concrete inserts at below grade cold joints.
- Provide notching, drilled holes according to Structural Engineers's recommendations or run roof furring strips perpendicular to roof joists to allow crossventilation of roof joist spaces. Maintain 1" minimum clear from top of insulation to bottom of decking where occurs.
- Pressure treated lumber typically at all exterior applications and concrete surfaces.
- Pursuant to MICC 19.02.020(F)(3)(d) all Japanese Knotweed and regulated Class A, B & C weeds identified on the King County Noxious Weed List as amended, shall be removed from the property. New landscaping associated with New Single Family Home shall not include any weeds identified on the KC Noxious Weed List.
- Any excavation or foundation work performed between October 1st and April 1st shall be subject to wet season moratorium requirements per MICC 19.07.060(D)(4)
- Per IRC R312 guards shall be installed on all open sided walking surfaces including stairs, ramps, landings, that are located more than 30 inches measured vertically to the floor or grade below. Guards shall have openings small enough that a 4" sphere cannot pass. All guards shall have a minimum overturn resistance 200 lb. per IRC Table 301.5. See R311.7.8 for stair railing requirements.

SYMBOLS:

&	and
@	at
⊕	centerline
X	by
∅	diameter
#	pound/number
##	degree
±	plus or minus
⊕	revisions / window designation
⊕	door designation
⊕	material designation

ABBREVIATIONS:

AB	anchor bolt
ADJ	adjustable
AFF	above finish floor
ARCH	architect/ural
BLDG	building
BN	beam
B.O.	bottom of
B.O.F.	bottom of footing
BTWN	between
CB	catch basin
CIP	cast in place
CJ	control joint
CLG	ceiling
CMU	concrete masonry unit
COL	column
CONC	concrete
CONT	continuous
DIA	diameter
DIM	dimension
DN	down
DR(S)	door(s)
DS	downspout
DWG	drawing
EA	each
EL	elevation
ELEC	electrical
ELEV	elevations
EQ	equal
EXIST	existing
EXH	exhaust
EXT	exterior
FB	flat bar
FD	floor drain
FDN	foundation
FE	fire extinguisher
FIN	finish
FOC	face of conc.
FOS	face of stud
FLR	floor
FOC	furnished by owner installed
FPHB	frost proof hose bib
FRT	fire retardant treated
FS	full size
FT	foot
FTNG	footing
GA	gauge
GALV	galvanized
GL	glass
GWB	gypsum wallboard
HB	hose bib
HC	hollow core
HM	hollow metal
HOR	horizontal
HP	high point
HR	hour/handrail
HT	height
ID	inside diameter
IN	inch/inches
INSUL	insulation
INT	interior
JNT	joint
KD	kin dried
LNDSPOG	landscaping low point
LP	light
LT	maximum
MDF	medium density fiberboard
MDO	medium density overlay
MECH	mechanical
MFR	manufacturer
MISC	miscellaneous
MIN	minimum
MTL	metal
NIC	not in contract
NO	number
NOM	nominal
NTS	not to scale
OA	overall
OC	on center
OD	outside diameter
OPD	overflow drain
OPNG	opening
OS	overflow scupper
OVR	over
PAV	pavers, paving
PLYWD	plywood
PR	pair
PT	paint/point
RAD	radius
RB	reinforcing bar
RD	roof drain
REQ'D	required
RES	resilient
RL	rain leader
RO	rough opening
SCHED	schedule(s)
SD	smoke detector
SF	square feet
SHT	sheet
SIM	similar
SPEC	specification
SQ	square
SS	stainless steel
ST	stone
STL	steel
SAF	self adhering glassing
TG	tempered glass
T&G	tongue and groove
THK	thick
T.O.	top of
TYP	typical
V	variable
VERT	vertical
VG	vertical grain
VIN	vinyl
VTR	vent through roof
W/	with
WP	waterproof
W/O	without
WWF	welded wire fabric

Studio Ectypos

ARCHITECTURE

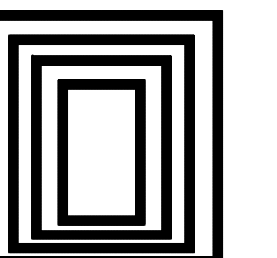

4212 W. Mercer Way
Mercer Island, WA 98040
t. (206)232-9147
www.studioectypos.com

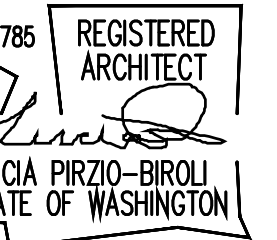

VANEY / SHINDE
 New Residence
 4207 West Mercer Way
 Mercer Island, WA 98040

Date:
 5/27/20 Permit Sub
 7/15/20 Early Comm't
 8/24/20 FND'N PERMIT
 9/8/20 FND'N REVISION
 10/30/20
 Sub-2 2006-006

Scale:

Sheet:

Project Information

A0.1

TOPOGRAPHIC & BOUNDARY SURVEY

SE 1/4 OF THE NE 1/4 OF SEC. 13, TWP. 24N., RGE. 4E., W.M.
CITY OF MERCER ISLAND, KING COUNTY, WA.

LEGAL DESCRIPTION:

THE WEST 82 FEET OF THAT PORTION OF TRACT 13 IN HARRY WHITE'S PLAT OF EAST SEATTLE ACRE TRACTS, AS PER PLAT RECORDED IN VOLUME 3 OF PLATS, PAGE 36, RECORDS OF KING COUNTY, LYING SOUTHERLY OF WEST MERCER WAY RIGHT-OF-WAY;

TOGETHER WITH THAT PORTION OF THE EAST 1/2 OF VACATED SECOND STREET ADJOINING ON THE WEST;

SITUATE IN THE CITY OF MERCER ISLAND, COUNTY OF KING, STATE OF WASHINGTON.

VERTICAL DATUM: (VISITED JANUARY 24, 2007) CITY OF MERCER ISLAND BENCH MARK # 4282 (NAVD 88)

FOUND 1" BRASS NAIL IN CONC (DN 0.95')
LOCATED 30' E DRIVEWAY #8005, EVERGREEN LANE.

ELEVATION ON NAIL = 141.19'

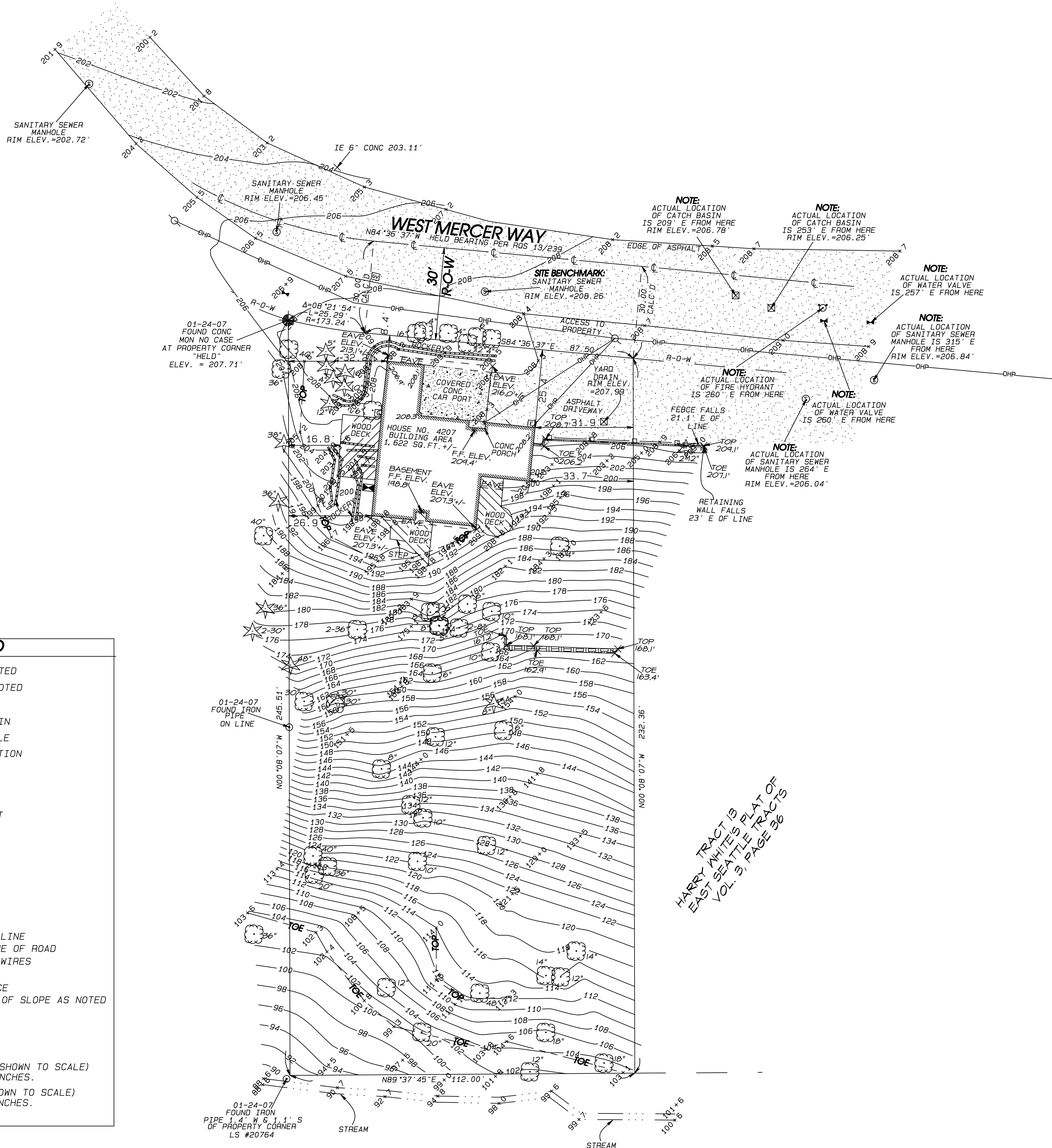

LEGEND	
	FOUND MONUMENT AS NOTED
	FOUND IRON PIPE AS NOTED
	UTILITY POLE
	CATCH BASIN/YARD DRAIN
	SANITARY SEWER MANHOLE
	FINISHED FLOOR ELEVATION
	ELECTRIC METER
	SPOT ELEVATION
	WATER VALVE
	AIR CONDITIONING UNIT
	FIRE HYDRANT
	GAS VALVE
	GAS METER
	ASPHALT SURFACE
	RET. WALL
	CONC SURFACE
	DECK
	BUILDING LINE
	CENTERLINE OF ROAD
	OVERHEAD WIRES
	ROCKERY
	WOOD FENCE
	TOP/ TOE OF SLOPE AS NOTED
	EAVES
	CONC CONCRETE R-O-W RIGHT-OF-WAY
	() RECORD
	DECIDUOUS TREE (NOT SHOWN TO SCALE) TRUNK DIA SHOWN IN INCHES.
	CONIFER TREE (NOT SHOWN TO SCALE) TRUNK DIA SHOWN IN INCHES.

HARRY TRACT 13
HARRY WHITE'S PLAT OF
EAST SEATTLE ACRE TRACTS
VOL. 3, PAGE 36

BEARING MERIDIAN:
A BEARING OF N84°36'37"W ON THE
CENTERLINE OF WEST MERCER WAY,
PER RECORD OF SURVEY AS RECORDED
IN BOOK 13, PAGE 239, RECORDS OF KING
COUNTY, WA.

SURVEYOR'S NOTES:

- 1) THE TOPOGRAPHIC SURVEY SHOWN HEREON WAS PERFORMED IN JANUARY OF 2007. THE FIELD DATA WAS COLLECTED AND RECORDED ON MAGNETIC MEDIA THROUGH AN ELECTRIC THEODOLITE. THE DATA FILE IS ARCHIVED ON DISC OR CD. WRITTEN FIELD NOTES MAY NOT EXIST. CONTOURS ARE SHOWN FOR CONVENIENCE ONLY. DESIGN SHOULD RELY ON SPOT ELEVATIONS.
- 2) SUBJECT PROPERTY TAX PARCEL NO. 936570-0163.
- 3) SUBJECT PROPERTY AREA PER THIS SURVEY IS 26,673 SQ. FT. ±.
- 4) A TITLE REPORT WAS NOT FURNISHED AND THEREFOR, EASEMENTS IF ANY, NOT SHOWN ON THIS MAP.

TOPOGRAPHIC & BOUNDARY SURVEY		
CHAN RESIDENCE 4207 W. MERCER WAY MERCER ISLAND, WA. 98040		
DWN. BY V.L.J.	DATE 01/26/2007	JOB NO. 7003
CHKD. BY K.B.G.	SCALE 1"=20'	SHEET 1 OF 1

GeoDimensions
6210 FAIRWAY PLACE SE
SNOQUALMIE, WA. 98065
PHONE (425) 458-4488
FAX (206) 686-2950

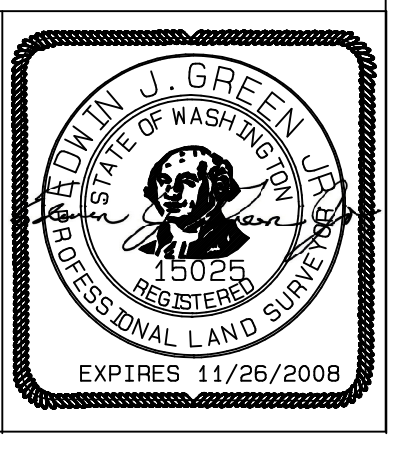

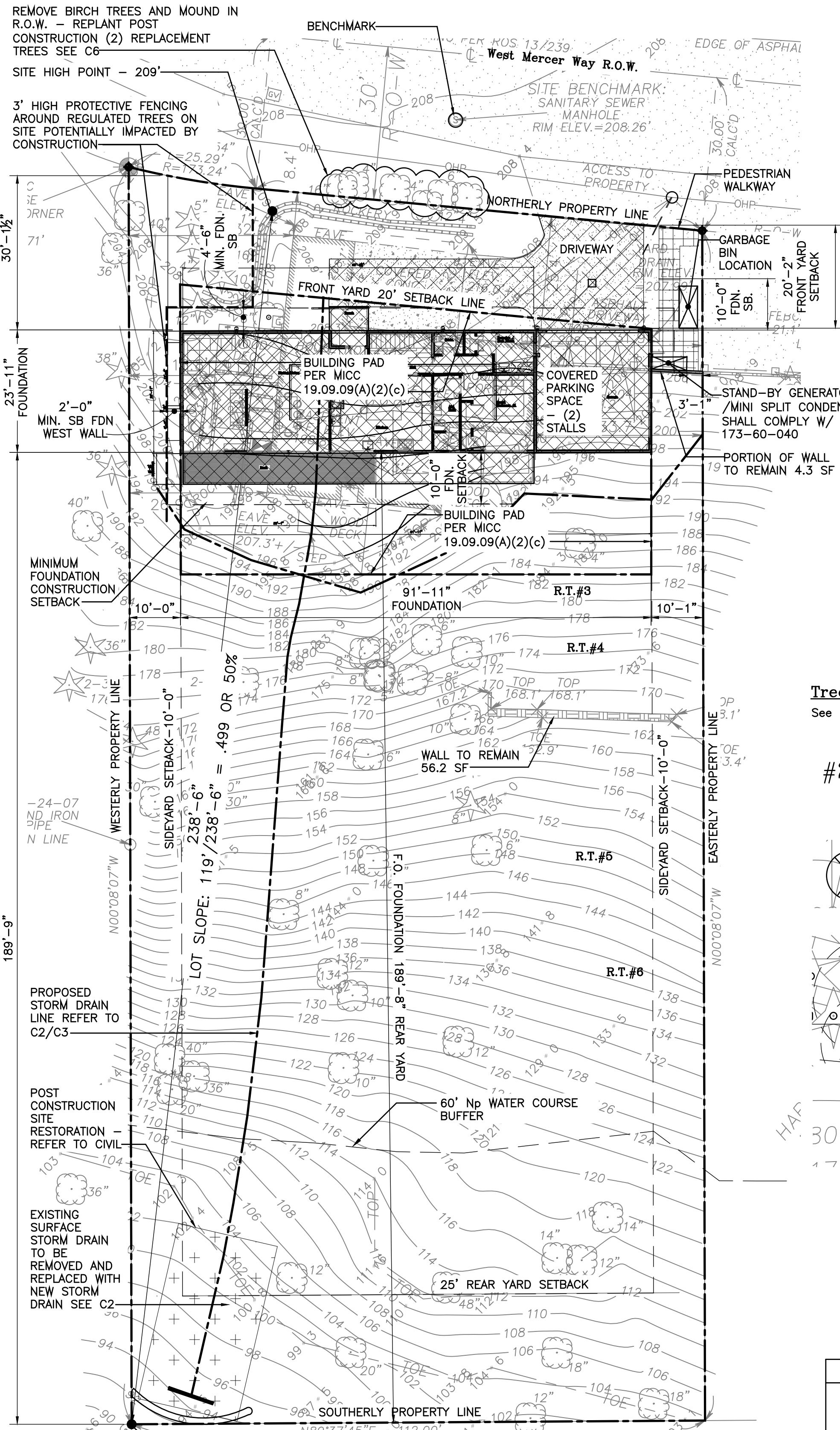

1 Site Plan
 Scale: 1/8"=1'-0"

- SITE PLAN NOTES:**
- All existing structures, paving and miscellaneous hard surfaces to be demolished and removed.
 - Pursuant to MICC 19.02.020(F)(3)(d) all Japanese Knotweed and regulated Class A, B & C weeds identified on the existing County Noxious Weed List as amended, shall be removed from the property. New landscaping associated with New Single Family Home shall not include any weeds identified on the KC Noxious Weed List. See A1.1 for construction layout during shoring pile installation, excavation and foundation installation.
 - R.T.# - Replacement tree number. See C6 for tree replacement schedule.
 - Eaves shall protrude no more than 18" into front yard setback.
 - No eave shall protrude within the minimum side yard setback.
 - See 2/A1.0 for tree information and 2 & 3 /A1.1 for tree protection information.

LOT COVERAGE - EXTENDED ROOF OVERHANG

Lot Coverage & Hardscape Calculation
 Allowed Lot Coverage: 30% OF 26,673 SF OR 8001.9 SF

ROOFS:	2645 SF
DRIVEWAY:	833 SF
PROPOSED LOT COVERAGE:	3478 SF OR 13%

Required Landscape: 70% OF 26,673 SF OR 21,338.4 SF. Allowed hardscape 9% lot area or 2,400.6 SF per MICC 19.02.020(F)(3)(b)

EXIST. RETAINING WALLS: 60.5 SF

PAVERS: 166 SF

PROPOSED HARDSCAPE: 226.5 SF OR .1%

2 Critical Area Site Plan
 Scale: 1/8"=1'-0"

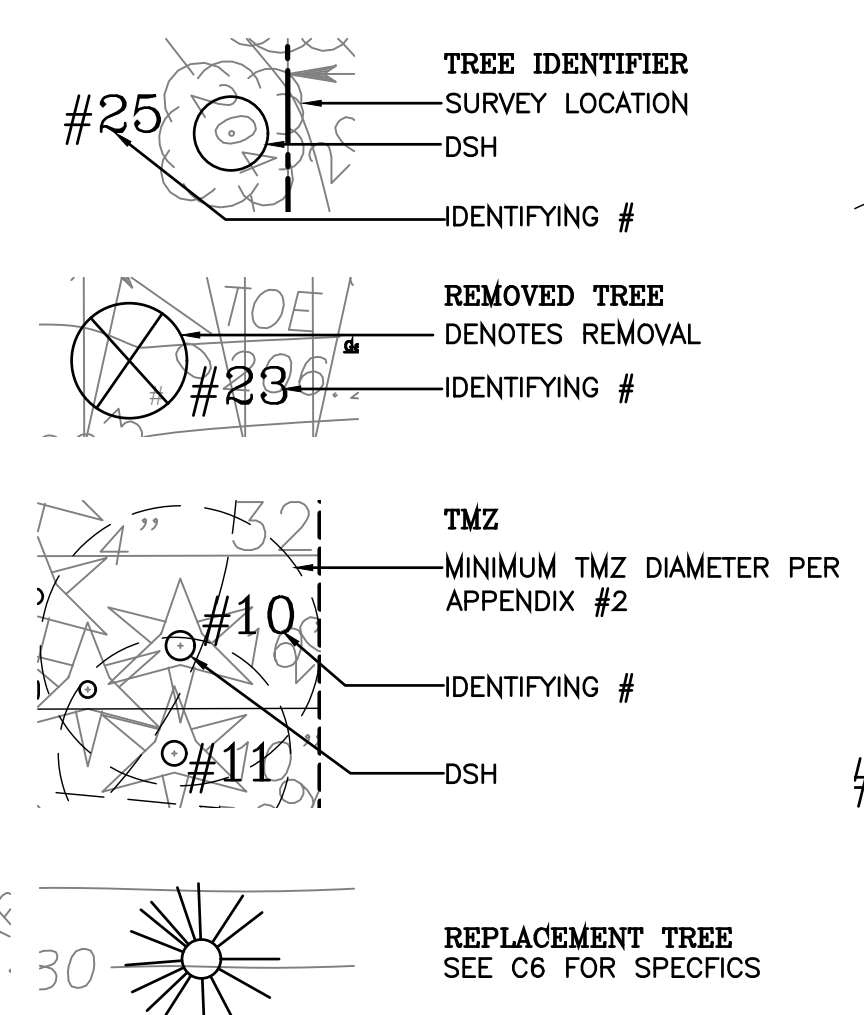

AVERAGE BUILDING ELEVATION

Mid-point Elev.	Wall Segment Length	Elev x Length
A= 204 ft	a= 23.9 ft	= 4875.6
B= 198.8 ft	b= 91.9 ft	= 18269.7
C= 204 ft	c= 23.9 ft	= 4875.6
D= 207 ft	d= 29.5 ft	= 6106.5
E= 208 ft	e= 3.0 ft	= 624.0
F= 208 ft	f= 6.9 ft	= 1435.2
G= 208 ft	g= 3.0 ft	= 624.0
H= 208 ft	h= 55.5 ft	= 11544.0
	total=	total=
	237.6 ft.	48354.6
Avg. Building Elevation =	203.5 ft.	
Allowed Building Height =	233.5 ft.	

3 Average Building Elevation Calculation
 Scale: 1/8"=1'-0"

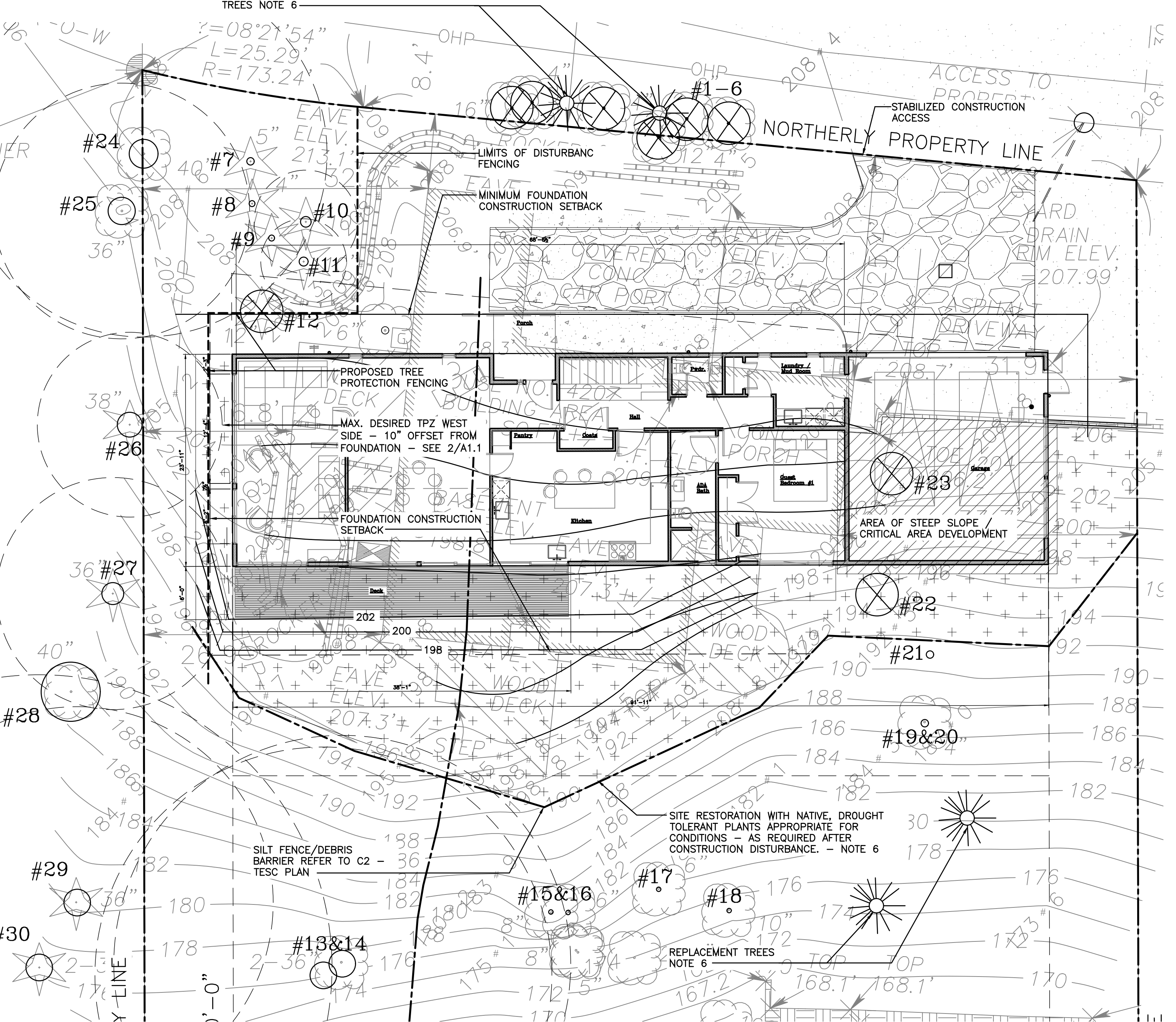

2 Critical Area Site Plan
 Scale: 1/8"=1'-0"

- Critical Area Plan Notes:**
- Coordinate BMP's per Civil design C2
 - Install erosion control BMP's prior to start of disturbance.
 - Protect stormwater BMP's before during and after construction.
 - Maintain and inspect BMP's
 - Site disturbance work performed during the wet season (between October 1 and April 1) requires Seasonal Development Limitation Waiver application from the City of Mercer Island.
 - See C6 for site restoration information: replacement trees; general planting restoration; restoration in watercourse setback. All trees and restoration plantings shall be placed on a hillside and planted by hand. No heavy machinery shall be used on hillside in restoration work.

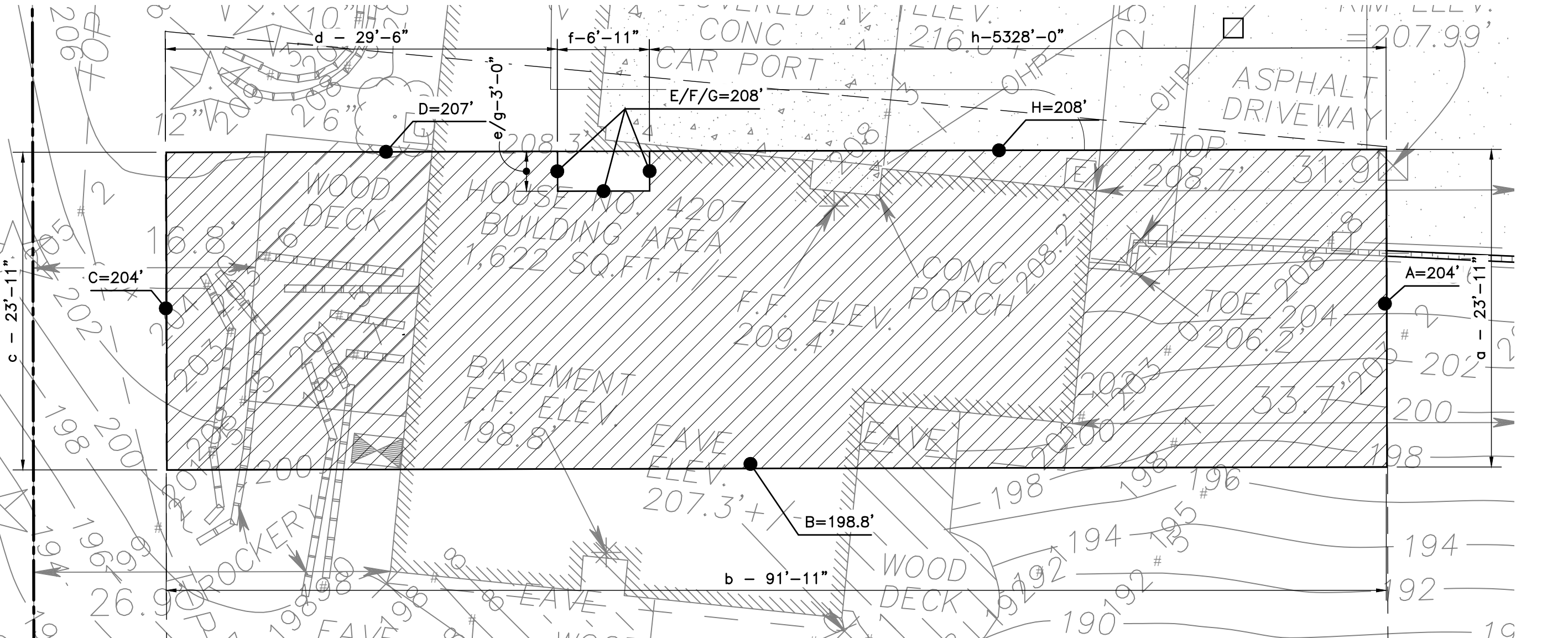

3 Average Building Elevation Calculation
 Scale: 1/8"=1'-0"

Date:
 5/27/20 Permit Sub
 7/15/20 Early Com'nts
 8/24/20 FND N PERMIT
 9/8/20 FND N REVISION
 10/30/20
 Sub-2 2006-006

Scale:
 Sheet:

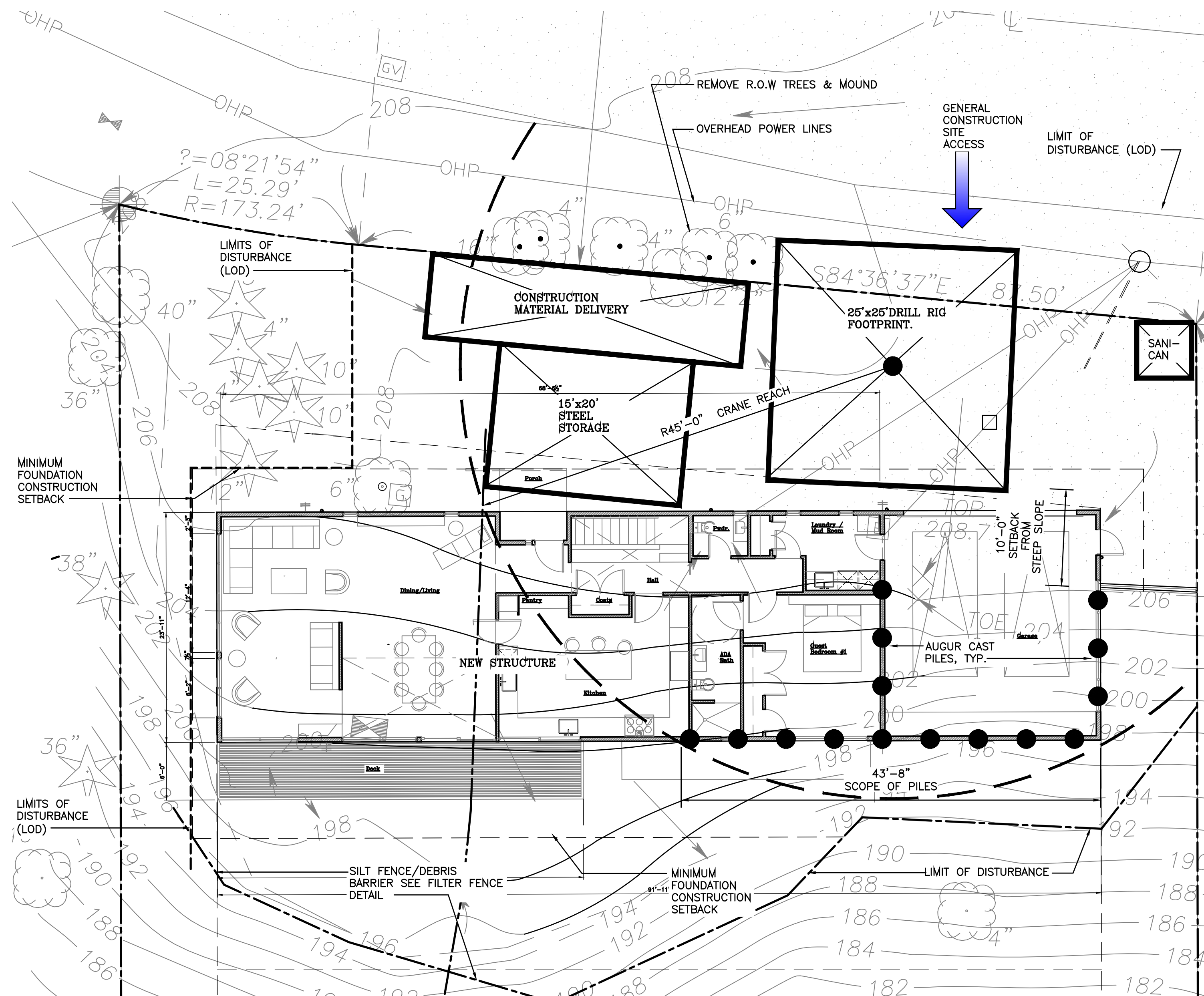

1 Site Plan - Shoring Layout
Scale: 1/8"=1'-0"

Shoring Layout Site Plan Notes:
1. See S2.1 for scope of shoring piles
2. Setback from steep-slope to minimize impact.
3. All spoils from pile drilling shall be immediately removed. No spoils shall remain on the hillside.

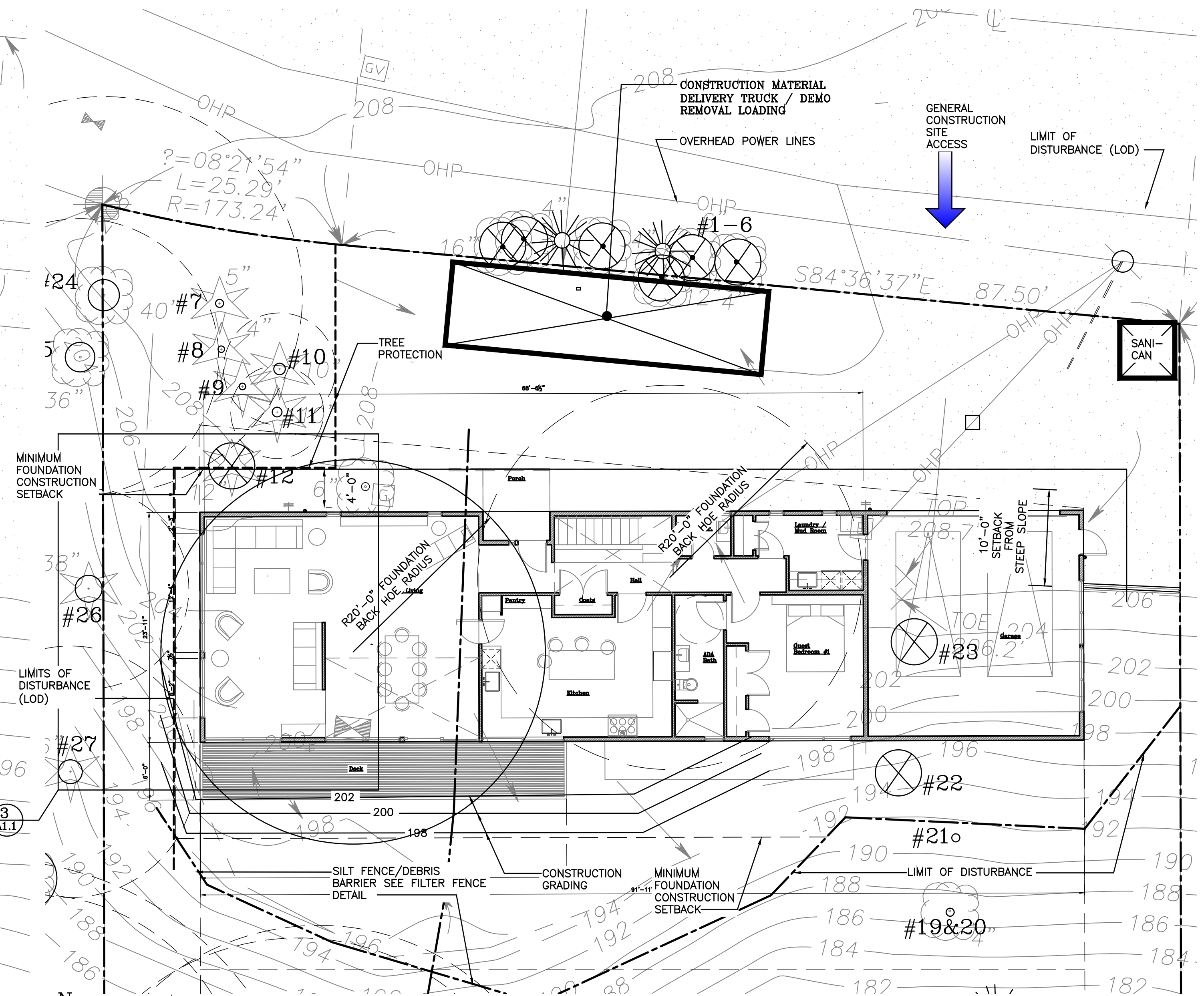

2 Site Plan - Footing Layout
Scale: 1/8"=1'-0"

Footing Layout Site Plan Notes:
1. See S2.1 for scope of pin piles
2. Setback from steep-slope to minimize impact.
3. See 3/A1.1 for tree protection strategy
4. After foundation work redistribute excavation soil to original profile. No soil export from site except soil displaced by foundation

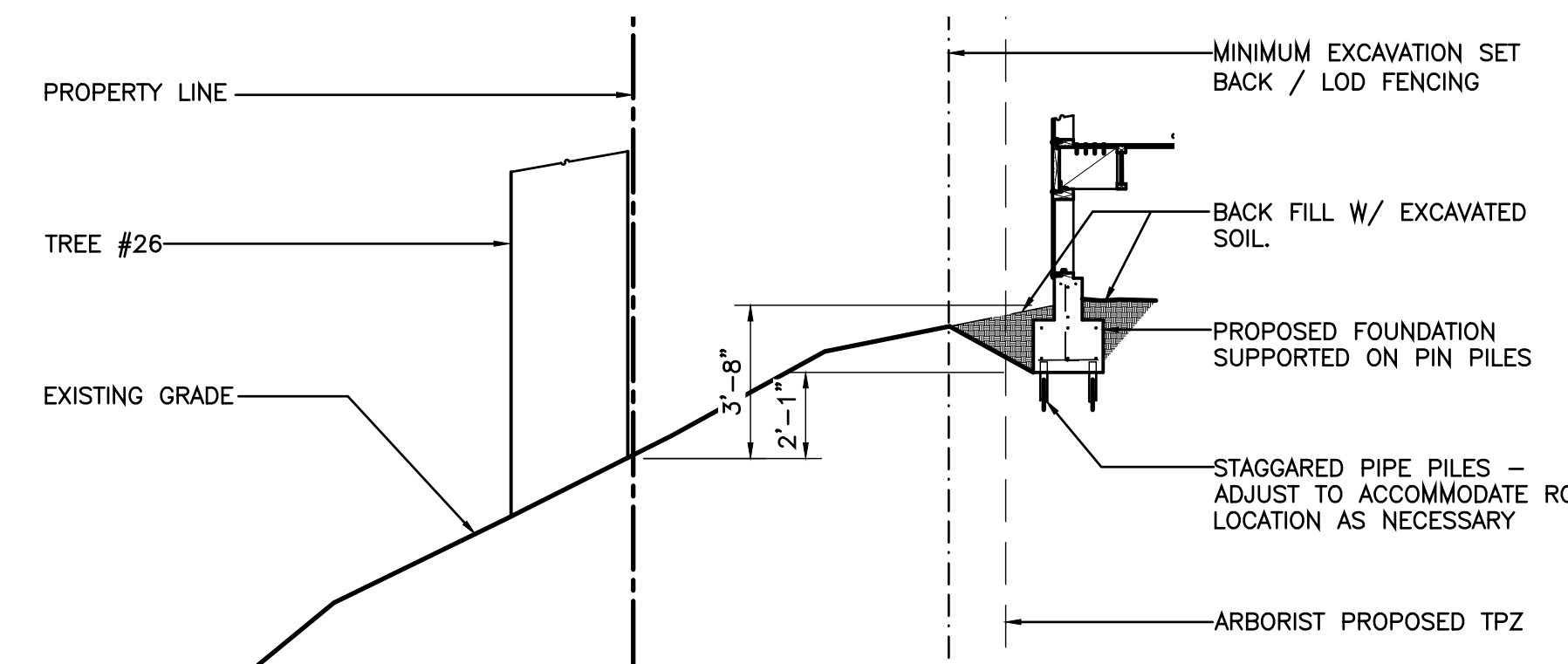

4 Section @ Tree #26
Scale: 1/4"=1'-0"

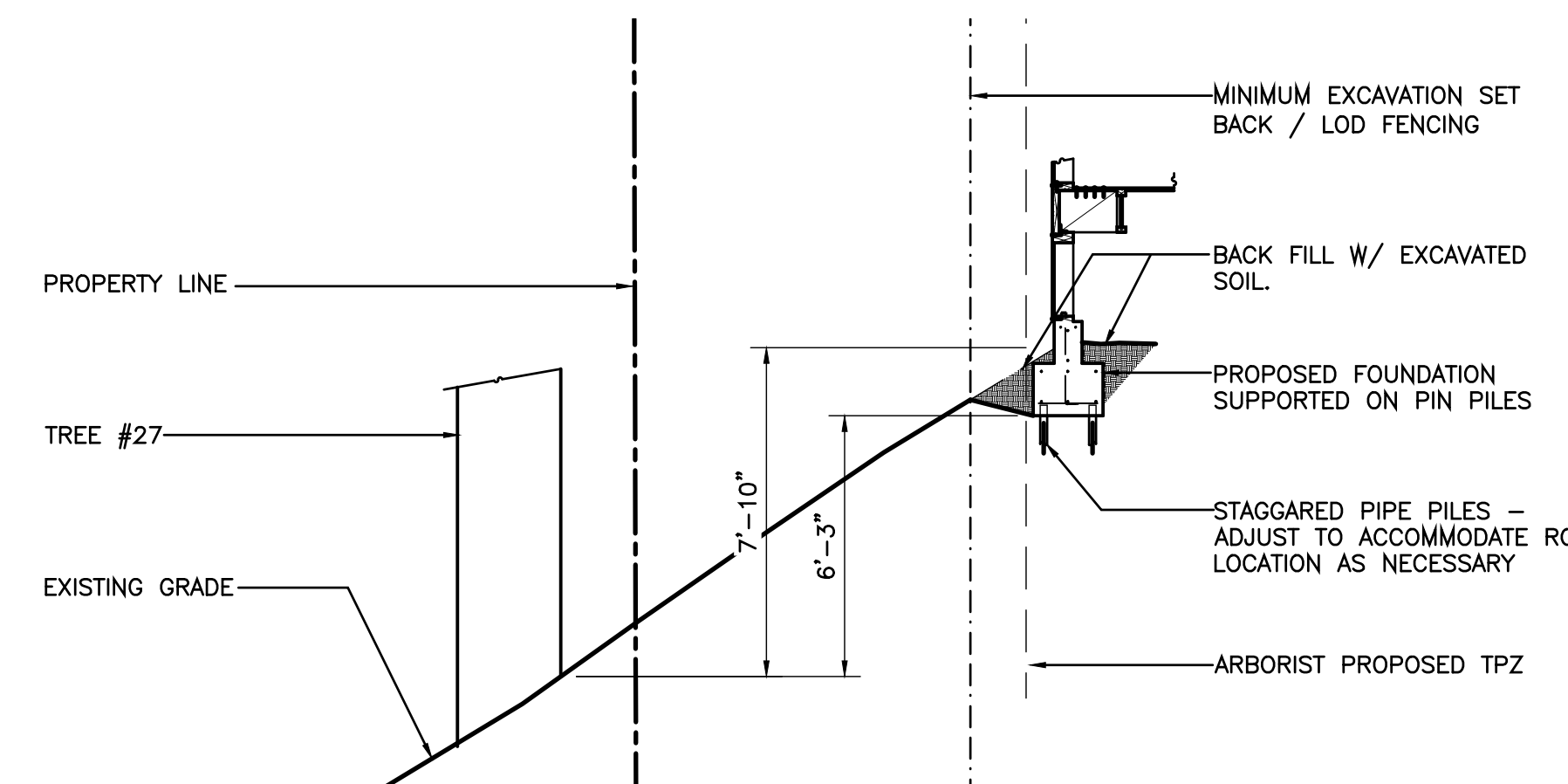

5 Section @ Tree #27
Scale: 1/4"=1'-0"

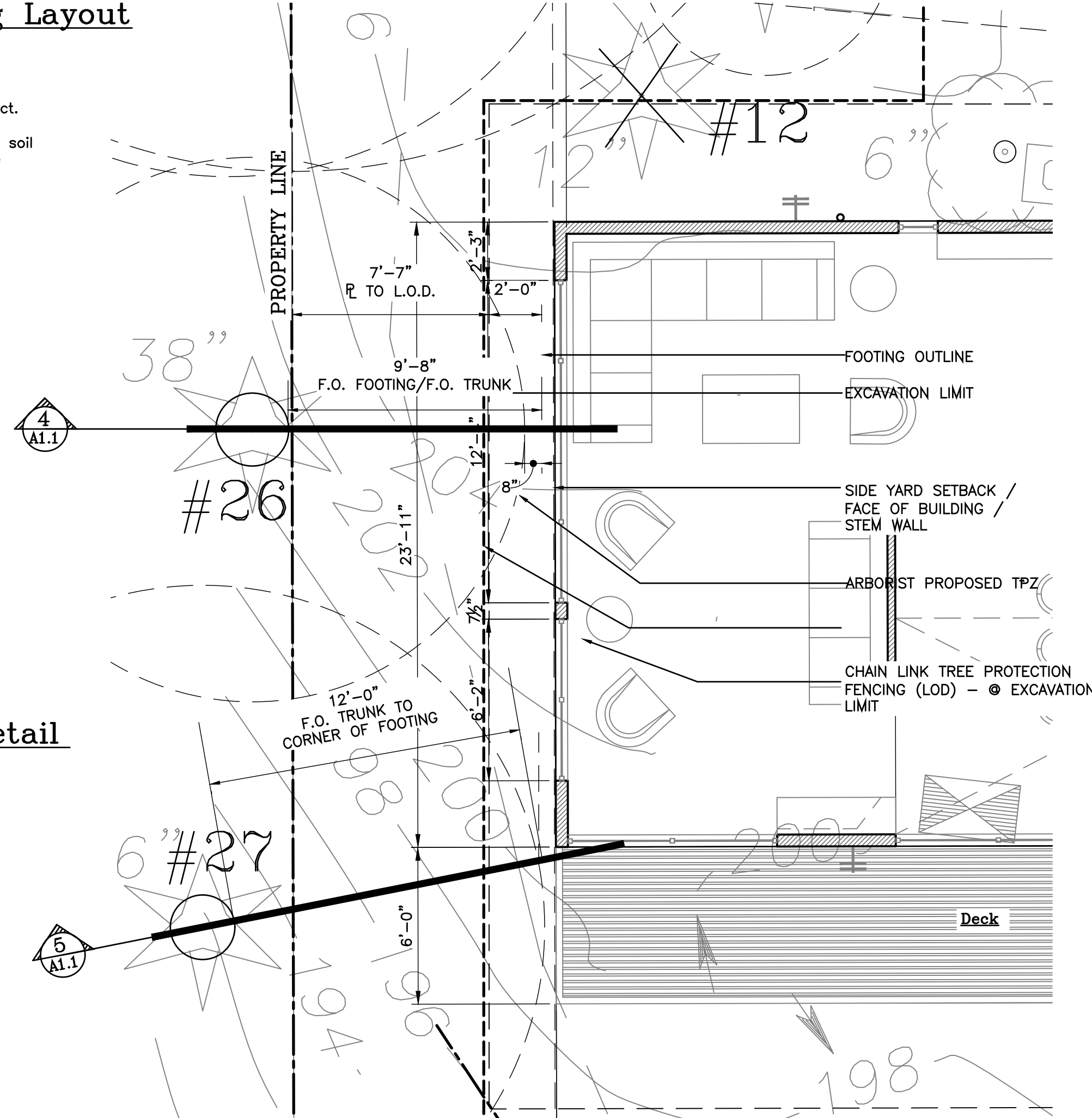

3 Site Plan - TPZ Detail
Scale: 1/4"=1'-0"

Site Plan - TPZ Detail Notes:
1. Tree protection fencing required prior to any work in the proximity of the tree root zone.
2. Prior to any excavation, air excavation under the direction of a certified arborist is required to determine if there is a need for an above grade beam design to avoid root damage. Also, call for an inspection by the city arborist at 206-275-7713. If an above grade beam is required, the design shall be submitted to the city as a deferred submittal for review and approval.

Date:
5/27/20 Permit Sub
7/15/20 Early Com's
8/24/20 FND N PERMIT
9/8/20 FND N REVISION
10/30/20
Sub-2 2006-006

Scale:
Sheet:

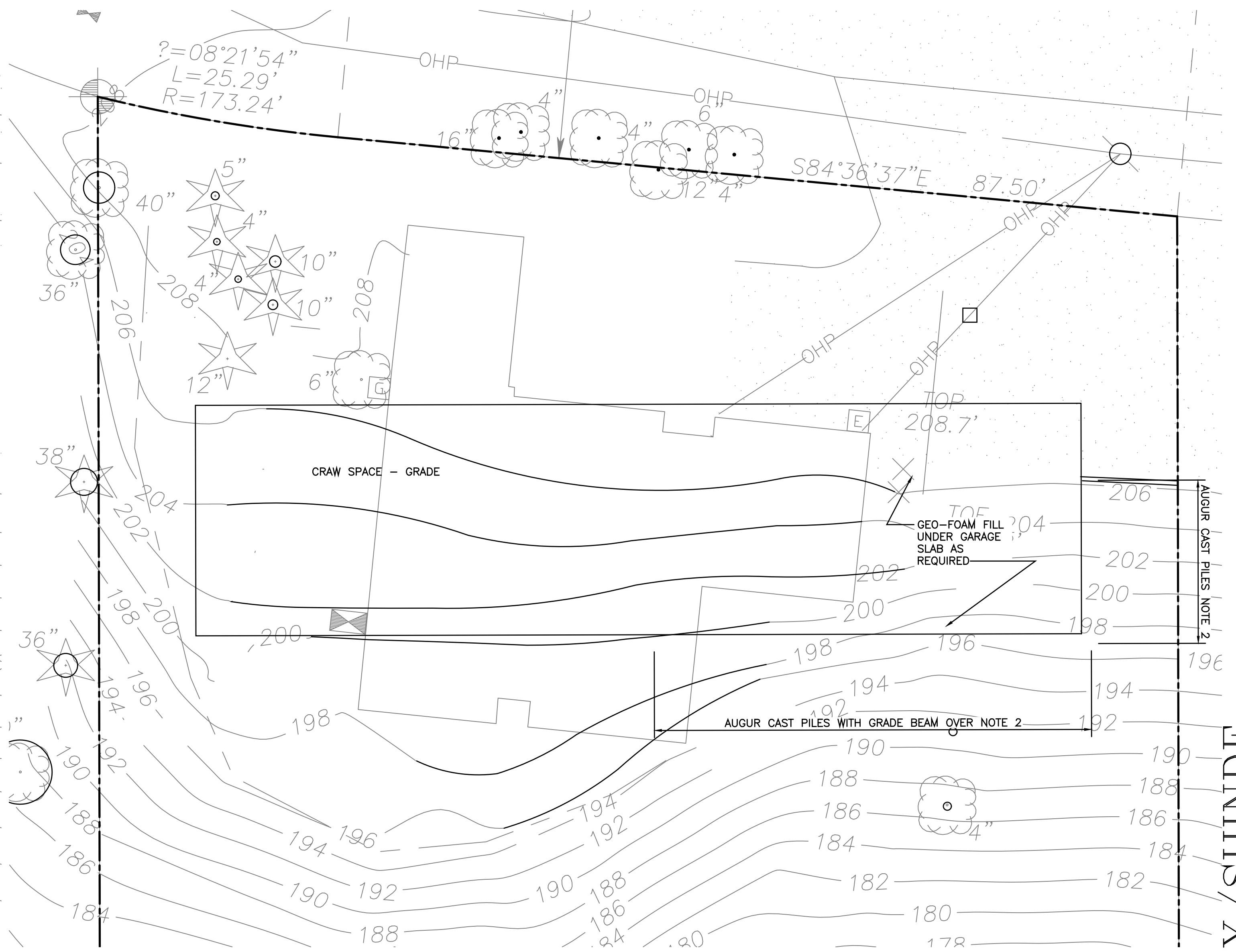
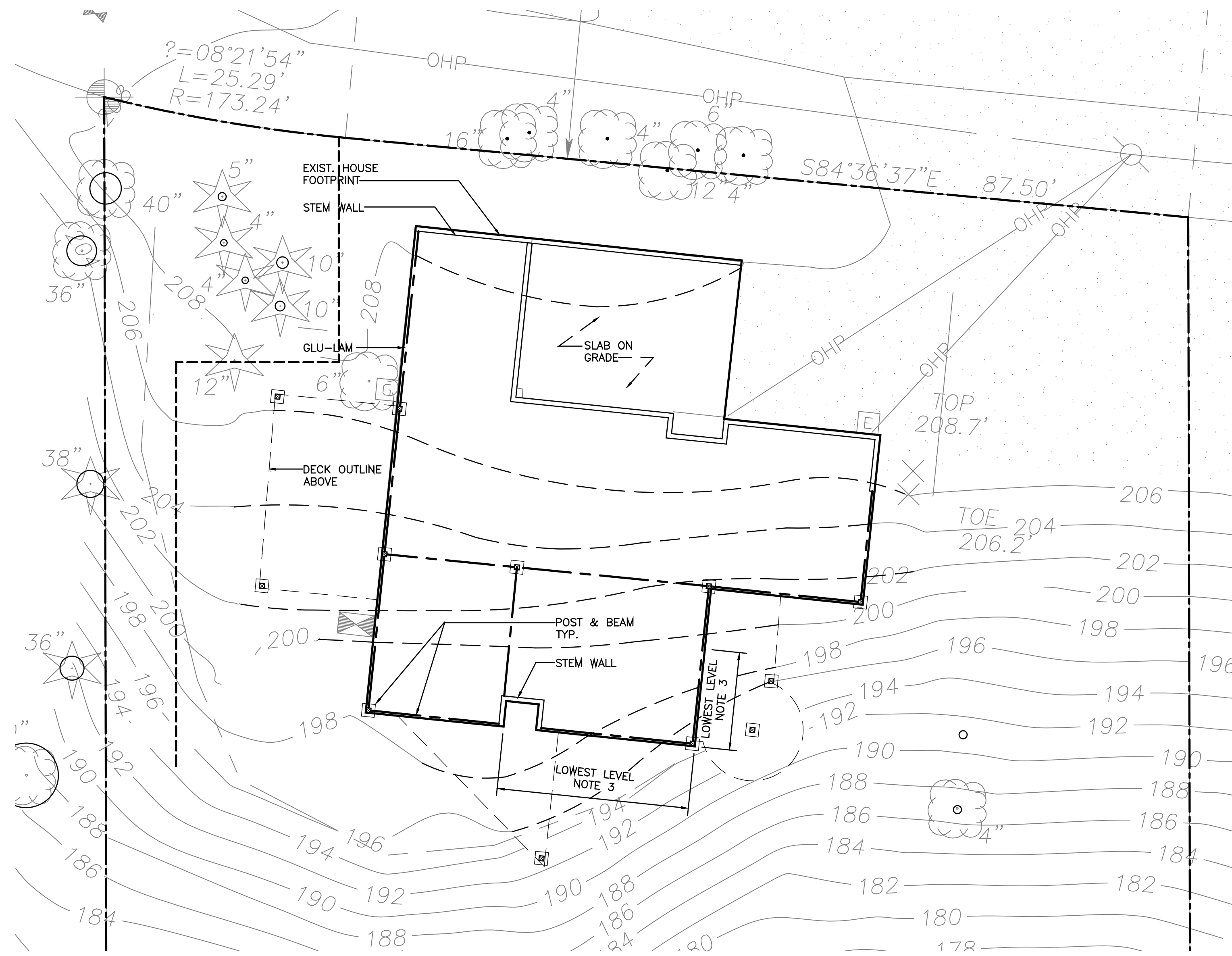

1 Existing Grading & Foundation Plan
Scale: 1/8"=1'-0"

1 Finish Grading @ Proposed Foundation
Scale: 1/8"=1'-0"

- EXISTING GRADING NOTES**
- Existing structure is primarily post and beam on hillside with little to no grading - natural slope carries through under decks and the crawl space
 - Existing post and beam on concrete pads - to be removed
 - Existing lowest level - wood framed floor resting on grade where occurs.
 - Existing glu-lams resting on dirt where occurs.

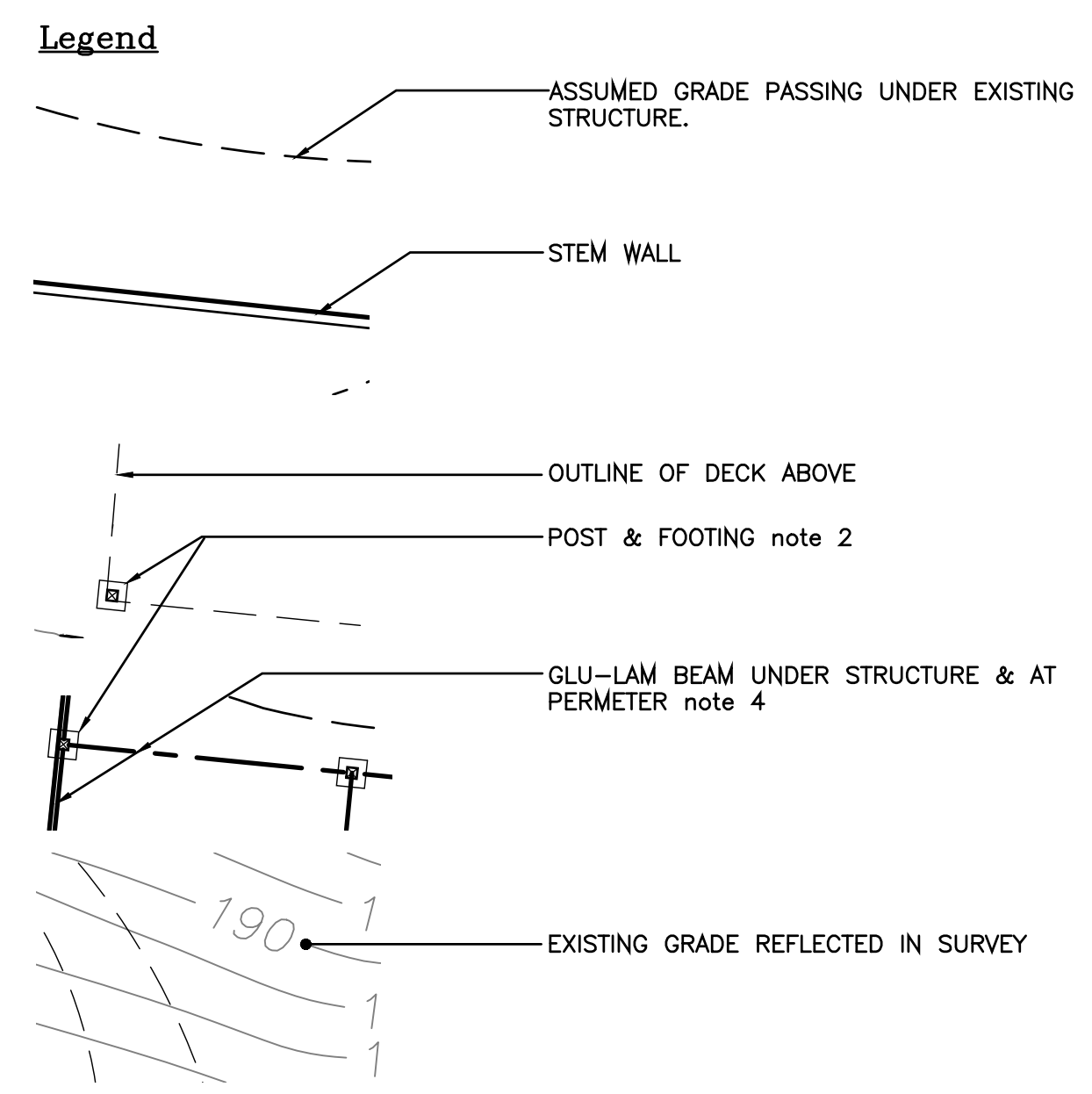

- PROPOSED GRADING NOTES**
- Proposed foundations intended to minimize grading. Post construction any disturbance shall be returned original grade.
 - Augur cast piles - drilled without excavation with grade beam poured over top.
 - Pipe piles minimize excavation for footings to meet bearing.
 - All grading returned to pre-construction condition. No export outside foundation foot print.

VANEY / SHINDE
New Residence
4207 West Mercer Way
Mercer Island, WA 98040

Date:
5/27/20 Permit Sub
7/15/20 Early Comm'ts
8/24/20 FND N PERMIT
9/8/20 FND N REVISION
10/30/20
Sub-2 2006-006

Scale:
Sheet:

Demo/Grading
Site Plan
A1.2

GENERAL NOTES

- ALL WORK AND MATERIALS SHALL BE IN ACCORDANCE WITH THE LATEST EDITION OF THE CITY OF MERCER ISLAND STANDARD SPECIFICATIONS, AND WSDOT/APWA STANDARD SPECIFICATIONS, LATEST EDITION. THE CITY OF MERCER ISLAND RESERVES THE RIGHT TO REJECT ANY DAMAGED AND/OR NON-COMPLIANT CONSTRUCTION MATERIAL.
- PRIOR TO ANY CONSTRUCTION ACTIVITY, THE CONTRACTOR SHALL SCHEDULE AND ATTEND A PRE-CONSTRUCTION CONFERENCE WITH THE CITY OF MERCER ISLAND CONSTRUCTION INSPECTION PERSONNEL.
- AN APPROVED PLAN SET MUST BE ON THE JOB SITE WHENEVER CONSTRUCTION IS IN PROGRESS.
- ALL SITE WORK IMPROVEMENTS SHALL BE CONSTRUCTED TO OBTAIN STREET USE AND ANY OTHER RELATED PERMITS PRIOR TO ANY CONSTRUCTION ACTIVITY.
- IT SHALL BE THE SOLE RESPONSIBILITY OF THE CONTRACTOR TO OBTAIN STREET USE AND ANY OTHER RELATED PERMITS PRIOR TO ANY CONSTRUCTION ACTIVITY.
- ANY APPROVED CUTS OF EXISTING PUBLIC ROADWAYS SHALL BE BACK FILLED AND COMPACTED IN ACCORDANCE WITH CITY OF MERCER ISLAND STANDARDS. ALL CUTS INTO EXISTING ASPHALT SHALL BE ALONG NEAT, CONTINUOUS, SAWED, OR WHEEL CUT LINES. A TEMPORARY COLD MIX PATCH MUST BE PLACED IMMEDIATELY AFTER BACKFILL AND COMPACTION. THIS EXISTING ROAD CUT SHALL BE REPLACED WITH AT LEAST THREE (3) INCHES OF COMPACTED CL "B" ASPHALT CONCRETE, SIX (6) INCH CRUSHED ROCK SURFACING TOP COURSE (5/8 INCH MINUS), AS REQUIRED DEPENDENT UPON A SOILS ENGINEER'S RECOMMENDATION AND TESTS. IN NO CASE SHALL THE REPLACEMENT BE LESS THAN THE EXISTING SECTION.
- PAVED SURFACES INCLUDING ROADWAYS, SIDEWALKS, AND CURBS THAT ARE DAMAGED BY NEW CONSTRUCTION SHALL BE REPAIRED AS REQUIRED BY THE CITY OF MERCER ISLAND INSPECTOR.
- ALL LOCATIONS OF EXISTING UTILITIES SHOWN HEREON HAVE BEEN ESTABLISHED BY FIELD SURVEY OR OBTAINED FROM AVAILABLE RECORDS AND SHOULD THEREFORE BE CONSIDERED APPROXIMATE ONLY AND NOT NECESSARILY COMPLETE. IT IS THE SOLE RESPONSIBILITY OF THE CONTRACTOR TO INDEPENDENTLY VERIFY THE ACCURACY OF ALL UTILITY LOCATIONS SHOWN AND TO FURTHER DISCOVER AND AVOID ANY OTHER UTILITIES NOT SHOWN HEREON WHICH MAY BE AFFECTED BY THE IMPLEMENTATION OF THIS PLAN.
- THE CONTRACTOR SHALL LOCATE AND PROTECT ALL CASTINGS AND UTILITIES DURING CONSTRUCTION AND SHALL CONTACT THE UNDERGROUND UTILITIES LOCATOR SERVICE (1-800-424-5555) AT LEAST 48 HOURS PRIOR TO CONSTRUCTION.
- THE CONTRACTOR SHALL ADJUST ALL EXISTING MANHOLE RIMS, DRAINAGE STRUCTURE LIDS, VALVE BOXES, AND UTILITY ACCESS STRUCTURES TO FINISH GRADE WITHIN AREAS AFFECTED BY THE PROPOSED IMPROVEMENTS.
- UTILITY SERVICE CONNECTIONS SHOWN ON THIS PLAN ARE TO BE MAINTAINED PRIVATELY AND NOT BY THE CITY MERCER ISLAND.
- THE CONTRACTOR SHALL PROVIDE AND MAINTAIN TEMPORARY SEDIMENTATION COLLECTION FACILITIES TO ENSURE THAT SEDIMENT-LADEN WATER DOES NOT ENTER THE NATURAL OR PUBLIC DRAINAGE SYSTEM. AS CONSTRUCTION PROGRESSES AND UNEXPECTED (SEASONAL) CONDITIONS DICTATE, MORE SILTATION CONTROL FACILITIES MAY BE REQUIRED TO INSURE COMPLETE SILTATION CONTROL OF THE PROJECT. THEREFORE, DURING THE COURSE OF CONSTRUCTION IT SHALL BE THE OBLIGATION AND RESPONSIBILITY OF THE CONTRACTOR TO ADDRESS ANY NEW CONDITIONS THAT MAY BE CREATED BY HIS ACTIVITIES AND TO PROVIDE ADDITIONAL FACILITIES THAT MAY BE NEEDED TO PROTECT ADJACENT PROPERTIES.
- THE CONTRACTOR SHALL KEEP OFF-SITE STREETS CLEAN AT ALL TIMES BY SWEEPING. WASHING OF THESE STREETS WILL NOT BE ALLOWED WITHOUT PRIOR CITY OF MERCER ISLAND APPROVAL.
- ALL TRAFFIC CONTROL SHALL BE IN ACCORDANCE WITH THE TRAFFIC CONTROL MANUAL.
- CARE SHALL BE EXERCISED WHEN EXCAVATING NEAR EXISTING CHARGED WATER MAINS.

SURVEY NOTE:

UNDERGROUND UTILITIES AND EXISTING IMPROVEMENTS SHOWN ARE BASED UPON THE SURVEY "TOPOGRAPHIC AND BOUNDARY SURVEY, 4207 W. MERCER WAY, BY GOEDIMENSIONS, DATED JANUARY 26, 2007 AND RECORD DRAWINGS. NO WARRANTY OR GUARANTEE OF ACCURACY OR COMPLETENESS IS EITHER IMPLIED OR EXPRESSED. EXISTING UNDERGROUND UTILITIES AND IMPROVEMENTS HAVE BEEN SHOWN ON THIS DRAWING FOR THE PURPOSE OF ASSISTING THE CONTRACTOR IN LOCATING SAID UTILITIES AND IMPROVEMENTS IN THE FIELD. THE CONTRACTOR SHALL BE RESPONSIBLE FOR CHECKING WITH APPROPRIATE AGENCIES THAT MAY HAVE UNDERGROUND UTILITIES AND IMPROVEMENTS WITHIN THE PROJECT LIMITS AND FOR CHECKING LOCATIONS IN THE FIELD. THE CONTRACTOR SHALL BE SOLELY RESPONSIBLE FOR ANY AND ALL DAMAGE TO UNDERGROUND UTILITIES AND IMPROVEMENTS RESULTING FROM HIS OPERATION.

VERTICAL DATUM

PER SURVEY, CITY OF MERCER ISLAND BENCH MARK (NAVD 88) FOUND 1" BRASS NAIL IN CONC.(DN 0.95) LOCATED 30 FT EAST DRIVEWAY #8005, EVERGREEN LANE.

ELEVATION ON NAIL = 141.19'

GENERAL DRAINAGE NOTES

- ALL WORK AND MATERIALS SHALL BE IN ACCORDANCE WITH THE LATEST EDITION OF THE CITY OF MERCER ISLAND STANDARD SPECIFICATIONS AND WSDOT/APWA STANDARD SPECIFICATIONS, LATEST EDITION AND THE REQUIREMENTS OF THE DEPARTMENT OF ECOLOGY STORMWATER MANAGEMENT MANUAL FOR WESTERN WASHINGTON.
- PRIOR TO ANY CONSTRUCTION ACTIVITY, THE CONTRACTOR SHALL SCHEDULE AND ATTEND A PRE-CONSTRUCTION CONFERENCE WITH CITY OF MERCER ISLAND CONSTRUCTION INSPECTION PERSONNEL.
- ALL STORM DRAINAGE IMPROVEMENTS SHALL BE CONSTRUCTED IN ACCORDANCE WITH THESE APPROVED PLANS. ANY DEVIATION FROM THESE PLANS WILL REQUIRE APPROVAL FROM THE OWNER, ENGINEER AND APPROPRIATE PUBLIC AGENCIES.
- IT SHALL BE THE SOLE RESPONSIBILITY OF THE CONTRACTOR TO OBTAIN STREET USE AND ANY OTHER RELATED PERMITS PRIOR TO ANY CONSTRUCTION ACTIVITY.
- ALL STORM DRAIN PIPE MAY BE CONSTRUCTED OF ONE OF THE FOLLOWING MATERIALS UNLESS OTHERWISE SPECIFIED IN THE PLANS. ALL PIPE JOINTS MUST BE GASKETED WATERTIGHT AND MUST BE OF THE SAME MATERIAL AS THE PIPE. ALL PIPE SHALL HAVE A MINIMUM COVER AS SPECIFIED AND SHALL BE ADEQUATELY PROTECTED DURING CONSTRUCTION (REFER TO THE MANUFACTURE'S RECOMMENDATIONS FOR MINIMUM COVER FOR HEAVY EQUIPMENT LOADINGS). THE CITY OF MERCER ISLAND PUBLIC WORKS DEPARTMENT SHALL EXERCISE THE OPTION TO ACCEPT OR REJECT ALL DAMAGED OR NON-COMPLIANT CONSTRUCTION MATERIAL. THE CONTRACTOR/DEVELOPER SHALL BE RESPONSIBLE FOR ALL COSTS ASSOCIATED WITH REJECTED OR SUBSTITUTED CONSTRUCTION MATERIAL.
- PIPE SHALL BE AS FOLLOWS: PVC - FOUR (4) INCH THROUGH EIGHTEEN (18) INCH DIAMETER PIPE, WITH TWENTY FOUR (24) INCH TO THIRTY SIX (36) INCH OF COVER SHALL BE IN ACCORDANCE WITH ASTM D3034 SDR 21. FOUR (4) INCH THROUGH EIGHTEEN (18) INCH DIAMETER PIPE, WITH ASTM D3034 SDR 35 SHALL HAVE THIRTY SIX (36) INCHES MINIMUM COVER. ALL JOINTS SHALL BE PUSH-ON WITH RUBBER GASKETS. PVC STORM PIPE REQUIRES SAND COLLARS MEETING ASTM D-3034-78 SDR 35 SPECIFICATIONS (I.E. CATCH BASIN CONNECTION) OR KOR-N-SEAL BOOTS.
- ALL PIPE BEDDING SHALL BE APWA TYPE "F" FOR FLEXIBLE PIPE (I.E. PVC, SMP OR ADS). BEDDING MATERIAL SHALL BE 5/8 INCH MINUS CRUSHED ROCK ONLY.
- ALL TRENCH BACKFILL IN AREAS OF FUTURE PAVEMENT OR STRUCTURAL LOADING SHALL BE COMPACTED TO AT LEAST 95 PERCENT OF THE MAXIMUM DRY DENSITY PER ASTM D 1557-70 (MODIFIED PROCTOR). ALL OTHER AREAS SHALL BE COMPACTED TO 90 PERCENT MINIMUM).
- CONSTRUCTION OF DEWATERING (GROUNDWATER INTERCEPTION) SYSTEMS SHALL BE IN ACCORDANCE WITH THE APWA STANDARD SPECIFICATIONS, SECTION 61-3.02.
- THE CONTRACTOR SHALL KEEP OFF-SITE STREETS CLEAN AT ALL TIMES BY SWEEPING. WASHING THESE STREETS WILL NOT BE ALLOWED WITHOUT PRIOR CITY OF MERCER ISLAND APPROVAL.
- ALL STORMWATER FACILITIES WILL BE INSTALLED AND IN OPERATION PRIOR TO OR IN CONJUNCTION WITH ALL CONSTRUCTION ACTIVITY UNLESS THAT ACTIVITY EXCEEDS THE CAPACITY AND INTENT OF THE EROSION/SEDIMENTATION CONTROL FACILITY OR UNLESS OTHERWISE APPROVED BY THE CITY.
- RELAY EXISTING SERVICE DRAINS AND SIDE SEWERS TO CLEAR OVER OR UNDER THE NEW UTILITY AS APPROVED BY THE INSPECTOR.

EROSION CONTROL/CONSTRUCTION SEQUENCE

- ARRANGE AND ATTEND PRE-CONSTRUCTION MEETING WITH BETWEEN OWNER OR OWNER'S REPRESENTATIVE AND CITY OF MERCER ISLAND SITE INSPECTOR.
- CONTRACTOR'S SURVEYOR TO ESTABLISH AND STAKE OUT CONTROL POINTS FOR WORK.
- INSTALL STRAW WATTLE BARRIERS AND GRATE INLET PROTECTION.
- CONSTRUCT STABILIZED CONSTRUCTION ENTRANCE (IF REQUIRED).
- CLEAR AND GRUB AREA.
- REMOVE EXISTING PAVEMENT, SURFACE FEATURES AND MISCELLANEOUS ITEMS AS NOTED.
- COORDINATE REMOVAL AND CAPPING OF EXISTING UTILITY LINES WITH APPROPRIATE PURVEYOR.
- GRADE SITE PER PLAN. STABILIZE GRADED AREAS WITH TEMPORARY EROSION CONTROL MEASURES AS REQUIRED.
- CONSTRUCT SITE IMPROVEMENTS.
- HYDROSEED REMAINING DISTURBED AREAS.
- RETURN SILTATION CONTROL AREAS TO ORIGINAL GROUND CONDITIONS.
- REMOVE REMAINING TEMPORARY EROSION/SEDIMENTATION CONTROL ONLY AFTER SITE HAS BEEN STABILIZED AND CITY OF MERCER ISLAND SITE INSPECTOR HAS APPROVED THE REMOVAL.

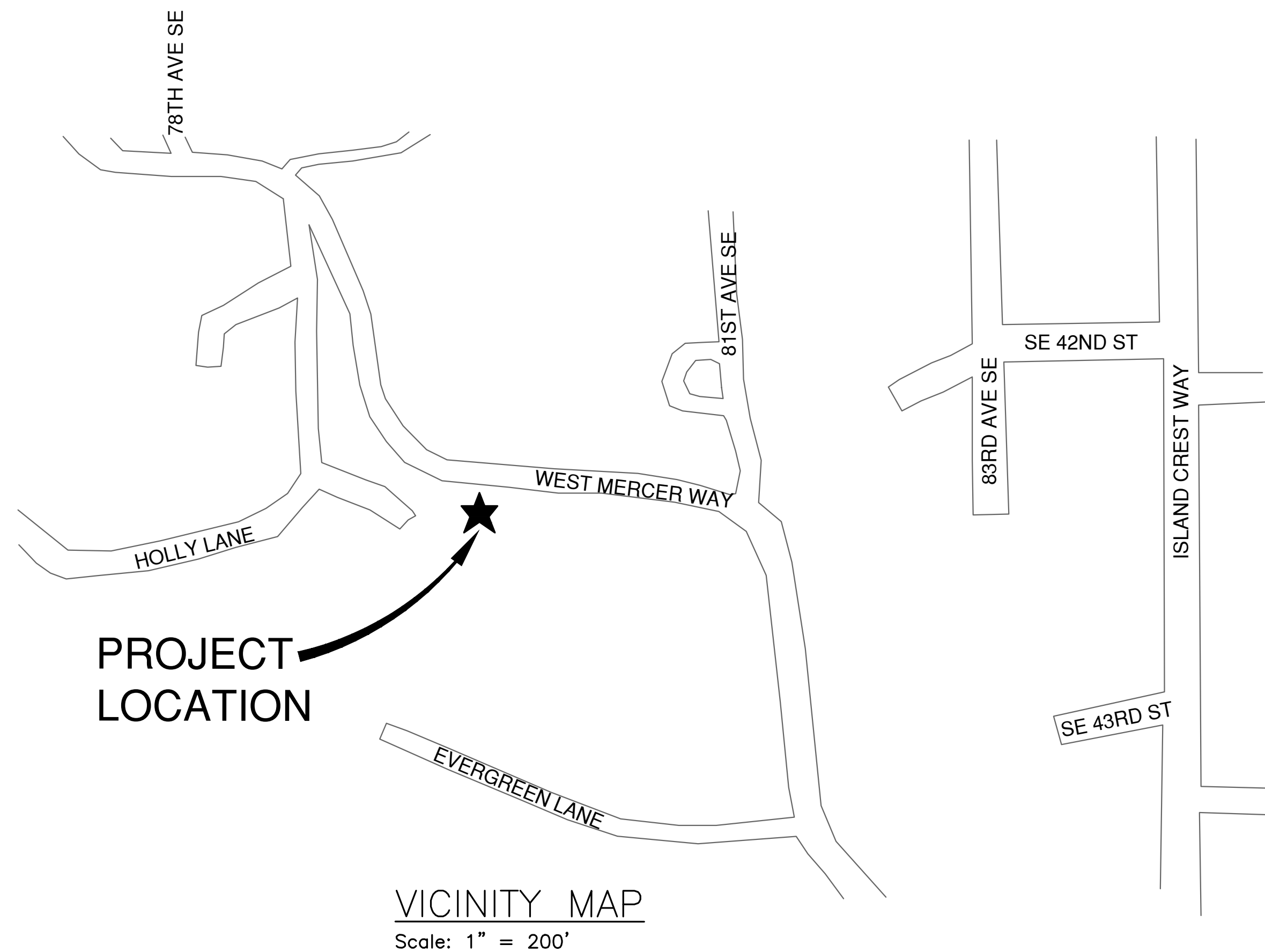

TEMPORARY EROSION/SEDIMENTATION CONTROL (ESC) NOTES

- APPROVAL OF THIS TEMPORARY EROSION/SEDIMENTATION CONTROL PLAN (TESC) DOES NOT CONSTITUTE AN APPROVAL OF PERMANENT ROAD OR DRAINAGE DESIGN (E.G. SIZE AND LOCATION OF ROADS, PIPES, RESTRICTORS, CHANNELS, RETENTION FACILITIES, UTILITIES, ETC.)
- THE IMPLEMENTATION OF THESE TESC AND THE CONSTRUCTION, MAINTENANCE, REPLACEMENT AND UPGRADING OF THESE TESC FACILITIES IS THE RESPONSIBILITY OF THE APPLICANT/CONTRACTOR UNTIL ALL CONSTRUCTION IS APPROVED.
- THE TESC FACILITIES SHOWN ON THIS PLAN MUST BE CONSTRUCTED PRIOR TO ALL CLEARING AND GRADING ACTIVITIES, AND IN SUCH A MANNER TO ENSURE THAT SEDIMENT LADEN WATER DOES NOT ENTER THE DRAINAGE SYSTEM OR VIOLATE APPLICABLE WATER STANDARDS.
- THE TESC FACILITIES SHOWN ON THIS PLAN ARE THE MINIMUM REQUIREMENTS FOR ANTICIPATED SITE CONDITIONS. DURING THE CONSTRUCTION PERIOD, THESE TESC FACILITIES SHALL BE UPGRADED (E.G. ADDITIONAL SUMPS, RELOCATION OF DITCHES AND SILT FENCES, ETC.) AS NEEDED FOR UNEXPECTED STORM EVENTS AND AS THE CITY REQUIRES.
- THE TESC FACILITIES SHALL BE INSPECTED DAILY BY THE APPLICANT/CONTRACTOR AND MAINTAINED AS NECESSARY TO ENSURE THEIR CONTINUED FUNCTIONING AND OPERATION.
- ANY AREA STRIPPED OF VEGETATION, INCLUDING ROADWAY EMBANKMENTS, WHERE NO FURTHER WORK IS ANTICIPATED FOR A PERIOD OF TWO (2) DAYS, SHALL BE IMMEDIATELY STABILIZED WITH THE APPROVED TESC METHODS (E.G. SEEDING, MULCHING, NETTING, EROSION BLANKETS, ETC.) GRASS SEEDING ALONE WILL BE ACCEPTABLE ONLY DURING THE MONTHS OF APRIL THROUGH OCTOBER INCLUSIVE.
- ANY AREA NEEDING TESC MEASURE, NOT REQUIRING IMMEDIATE ATTENTION, SHALL BE ADDRESSED WITHIN FIFTEEN (15) DAYS.
- THE TESC FACILITIES ON INACTIVE SITES SHALL BE INSPECTED AND MAINTAINED A MINIMUM OF ONCE A MONTH OR WITHIN 48 HOURS FOLLOWING A STORM EVENT AND AS THE CITY DEEMS NECESSARY.
- AT NO TIME SHALL MORE THAN ONE (1) FOOT OF SEDIMENT BE ALLOWED TO ACCUMULATE WITHIN A CATCH BASIN. ALL CATCH BASINS AND CONVEYANCE LINES SHALL BE CLEANED PRIOR TO PAVING. THE CLEANING OPERATION SHALL NOT FLUSH SEDIMENT LADEN WATER INTO THE DOWNSTREAM SYSTEM.
- STABILIZED CONSTRUCTION ENTRANCES AND WASH PADS PER CITY STANDARDS, SHALL BE INSTALLED AT THE BEGINNING OF CONSTRUCTION AND MAINTAINED FOR THE DURATION OF THE PROJECT. ADDITIONAL MEASURES MAY BE REQUIRED TO ENSURE THAT ALL PAVED AREAS ARE KEPT CLEAN FOR THE DURATION OF THE PROJECT.
- DURING THE TIME PERIOD OF NOVEMBER 1ST THROUGH MARCH 31ST, ALL PROJECT DISTURBED AREAS THAT ARE TO BE LEFT UNWORKED FOR MORE THAN TWO (2) DAYS SHALL BE COVERED BY ONE OF THE FOLLOWING COVER MEASURES: MULCH, SODDING OR PLASTIC COVERING.
- WHERE SEEDING FOR TEMPORARY EROSION CONTROL IS REQUIRED, FAST GERMINATING GRASSES SHALL BE APPLIED AT AN APPROPRIATE (E.G. ANNUAL OR PERENNIAL RYE APPLIED AT APPROXIMATELY 80 POUNDS PER ACRE).
- WHERE STRAW MULCH FOR TEMPORARY EROSION CONTROL IS REQUIRED, IT SHALL BE APPLIED AT A MINIMUM THICKNESS OF THREE (3) INCHES OR 3,000 LBS/ACRE.
- AS CONSTRUCTION PROGRESSES AND UNEXPECTED SEASONAL CONDITIONS DICTATE, AND AS THE CITY REQUIRES, THE PERMITTEE SHOULD ANTICIPATE THAT MORE TESC MEASURES WILL BE NECESSARY TO PROTECT ADJACENT PROPERTIES AND ENSURE MINIMUM WATER QUALITY FOR SITE RUNOFF. IT SHALL BE THE RESPONSIBILITY OF THE PERMITTEE TO ADDRESS DEFICIENT TESC CONDITIONS AND PROVIDE ADDITIONAL FACILITIES, OVER AND ABOVE MINIMUM REQUIREMENTS OUTLINED ON THE APPROVED PLANS.
- FILTER FABRIC FENCE SHALL BE USED WHERE NOTED ON THE PLANS OR AS DIRECTED BY THE CITY.

CALL 48 HOURS BEFORE YOU DIG
1-800-424-5555
OR CALL 8-1-1

Studio Ectypos
ARCHITECTURE

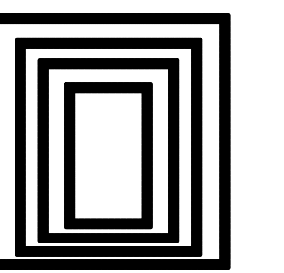

4212 W. Mercer Way
Mercer Island, WA 98040
t. (206)232-9147
www.studioectypos.com



Civil Engineer:

WR Consulting, Inc.
3611 45th Ave W.
Seattle, WA 98199
P: 206.285.1593

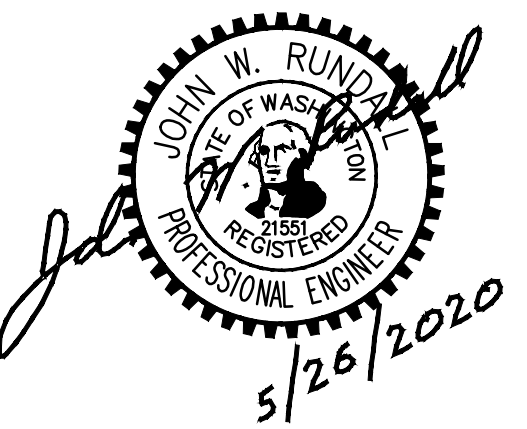

VANEY / SHINDE
 New Residence
 4207 West Mercer Way
 Mercer Island, WA 98040

PROJECT ADDRESS

4207 WEST MERCER WAY
MERCER ISLAND, WA 98040

LEGAL DESCRIPTION

THE WEST 82 FEET OF THAT PORTION OF TRACT 13 IN HARRY WHITE'S PLAT OF EAST SEATTLE ACRE TRACTS, AS PER PLAT RECORDED IN VOLUME 3 OF PLATS, PAGE 36, RECORDS OF KING COUNTY, LYING SOUTHERLY OF WEST MERCER WAY RIGHT OF WAY; TOGETHER WITH THAT PORTION OF THE EAST 1/2 OF VACATED SECOND STREET ADJOINING ON THE WEST; SITUATE IN THE CITY OF MERCER ISLAND, COUNTY OF KING, STATE OF WASHINGTON.

PARCEL NUMBER

936570-0163

Date:
5/21/20 Permit Set
8/19/20 Permit Rev.
9/16/20 Seasonal
Waiver Rev.
9/22/20 Permit Rev.

Scale: As Noted

Sheet: 1 of 6

GENERAL NOTES

C1

CALL 48 HOURS BEFORE YOU DIG
1-800-424-5555
OR CALL 8-1-1

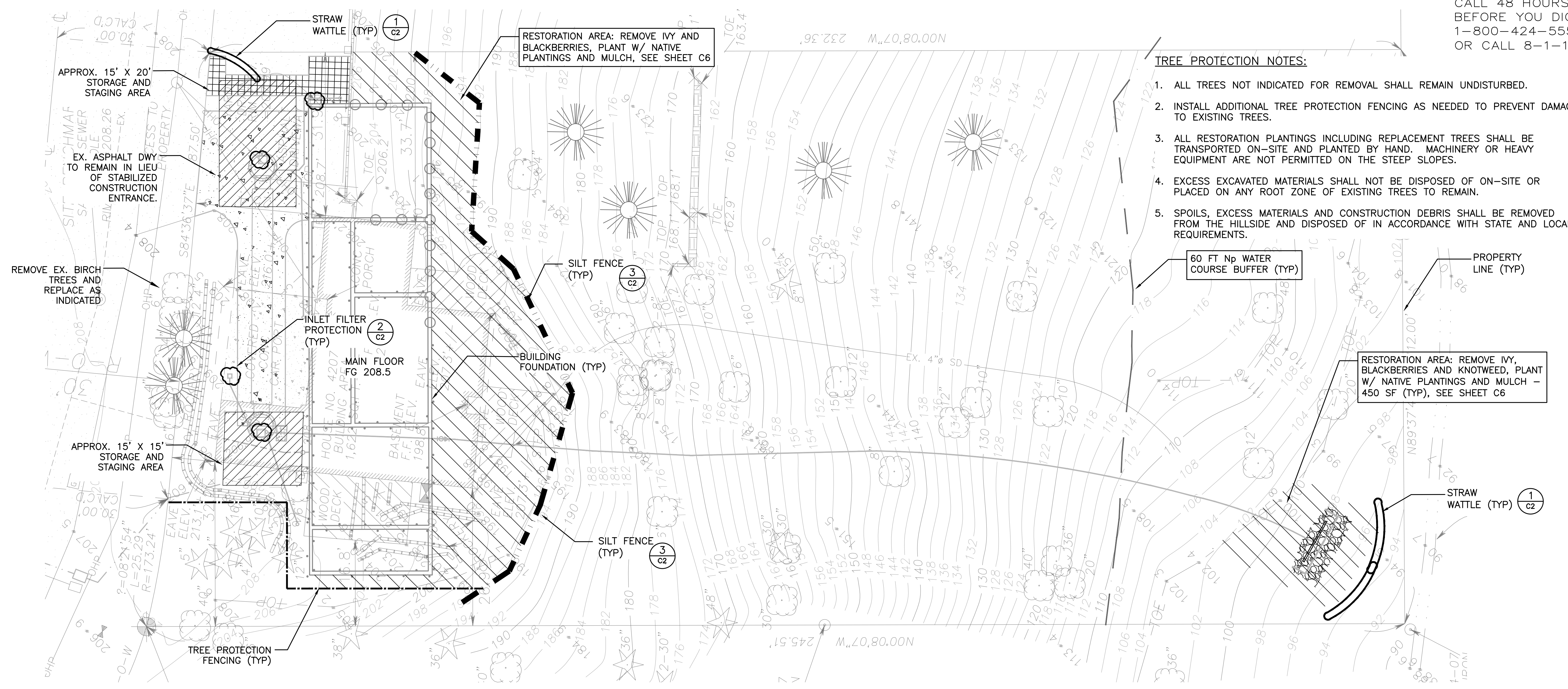

- TREE PROTECTION NOTES:**
1. ALL TREES NOT INDICATED FOR REMOVAL SHALL REMAIN UNDISTURBED.
 2. INSTALL ADDITIONAL TREE PROTECTION FENCING AS NEEDED TO PREVENT DAMAGE TO EXISTING TREES.
 3. ALL RESTORATION PLANTINGS INCLUDING REPLACEMENT TREES SHALL BE TRANSPORTED ON-SITE AND PLANTED BY HAND. MACHINERY OR HEAVY EQUIPMENT ARE NOT PERMITTED ON THE STEEP SLOPES.
 4. EXCESS EXCAVATED MATERIALS SHALL NOT BE DISPOSED OF ON-SITE OR PLACED ON ANY ROOT ZONE OF EXISTING TREES TO REMAIN.
 5. SPOILS, EXCESS MATERIALS AND CONSTRUCTION DEBRIS SHALL BE REMOVED FROM THE HILLSIDE AND DISPOSED OF IN ACCORDANCE WITH STATE AND LOCAL REQUIREMENTS.

- WATTLE DETAIL NOTES**
1. Install Wattles along contours. Installation shall be in accordance with Standard Specification 8-01.3(10).
 2. Securely knot each end of Wattle. Abut adjacent Wattles tightly, end to end, without overlapping the ends.
 3. Pilot holes may be driven through the Wattles and into the soil when soil conditions require.
 4. Live stakes may be used for Permanent installation and shall be in accordance with Standard Specification 9-14.6.
 5. Wattles shall be inspected regularly, and immediately after a rainfall produces runoff, to ensure they remain thoroughly entrenched and in contact with the soil.

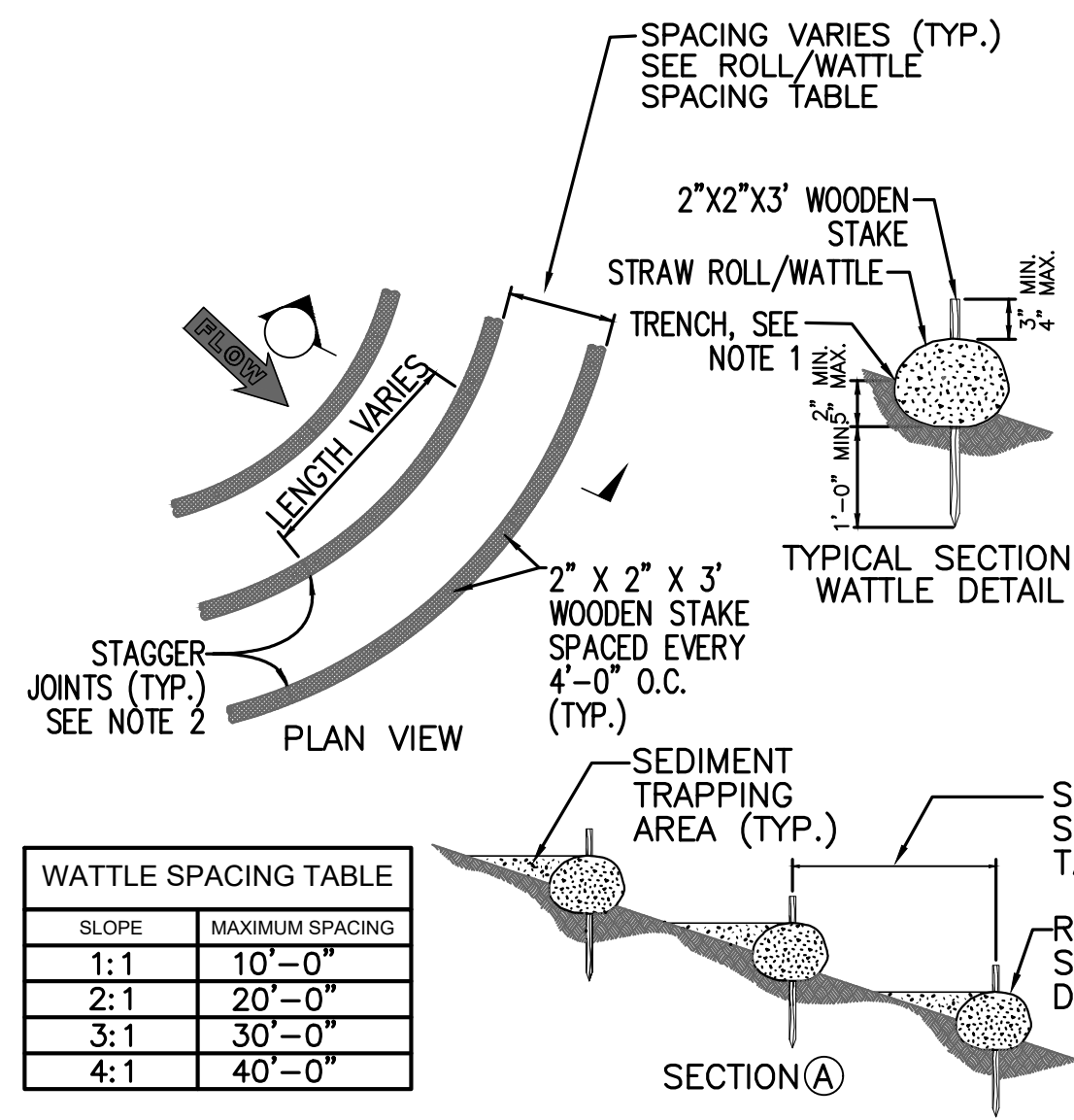

WATTLE SPACING TABLE

SLOPE	MAXIMUM SPACING
1:1	10'-0"
2:1	20'-0"
3:1	30'-0"
4:1	40'-0"

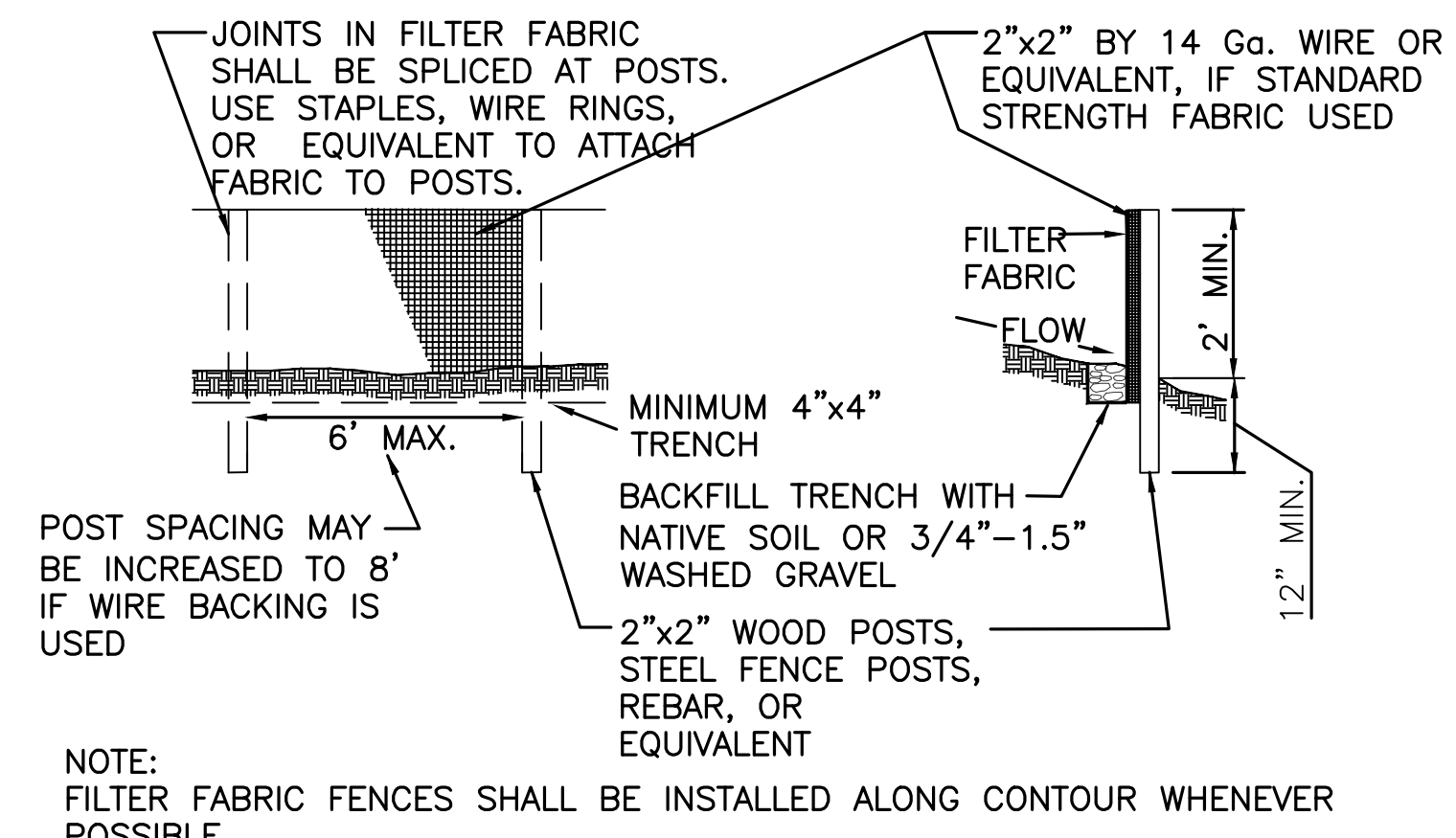
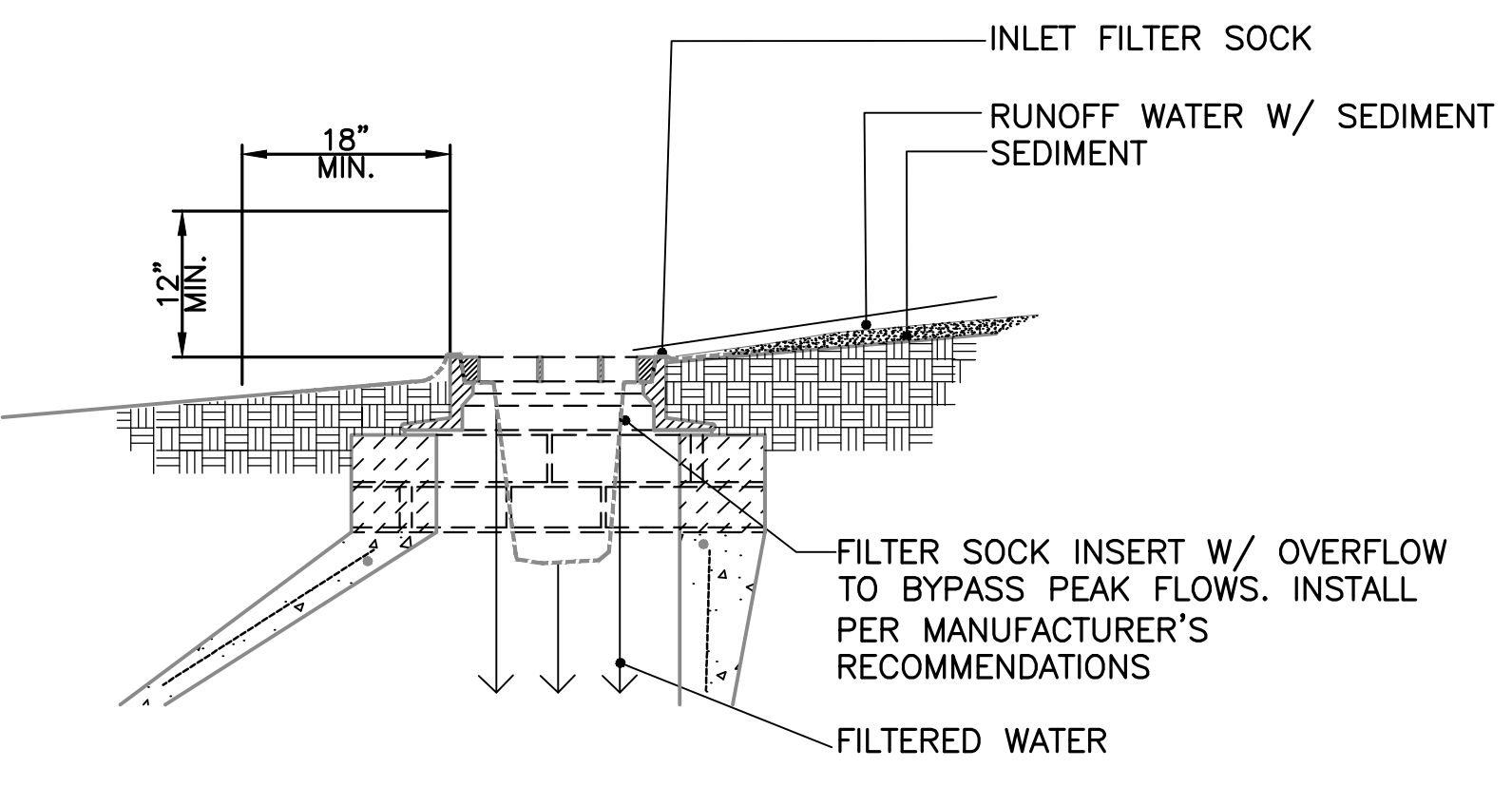
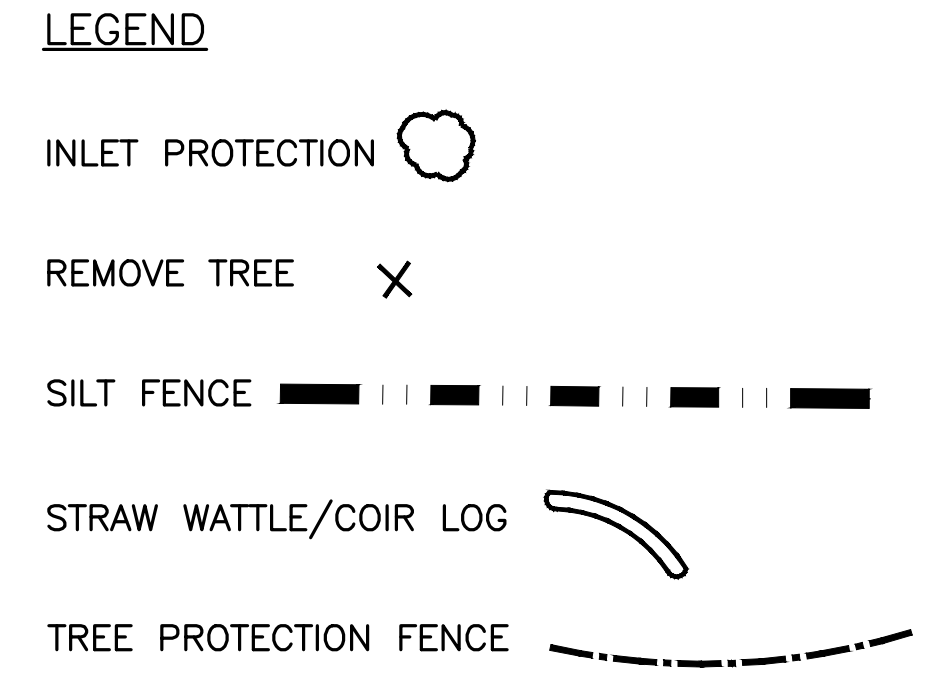

- TESC SEASONAL WAIVER NOTES:**
1. DURING CONSTRUCTION OF DETENTION SYSTEM OR OTHER SITE WORK, A STORMWATER MANAGEMENT FACILITY INCLUDING STORAGE (EG. BAKER TANKS), PUMPS, TREATMENT COMPONENTS AND SETTLING MEASURES SHALL BE IN PLACE AS NEEDED TO CONTROL SEDIMENT WHEN DISCHARGING STORMWATER TO THE STORM DRAIN SYSTEM.
 2. THE STORMWATER MANAGEMENT FACILITY SHALL BE MAINTAINED AND OPERATED AS REQUIRED TO PREVENT THE DISCHARGE OF SEDIMENT LADEN SOILS FROM THE SITE.

Date:
5/21/20 Permit Set
8/19/20 Permit Rev.
9/16/20 Seasonal Waiver Rev.
9/22/20 Permit Rev.

CALL 48 HOURS BEFORE YOU DIG
1-800-424-5555
OR CALL 811-1-1

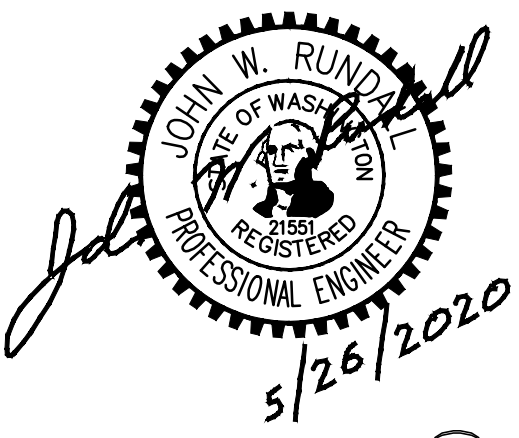

VANEY / SHINDE
New Residence
4207 West Mercer Way
Mercer Island, WA 98040

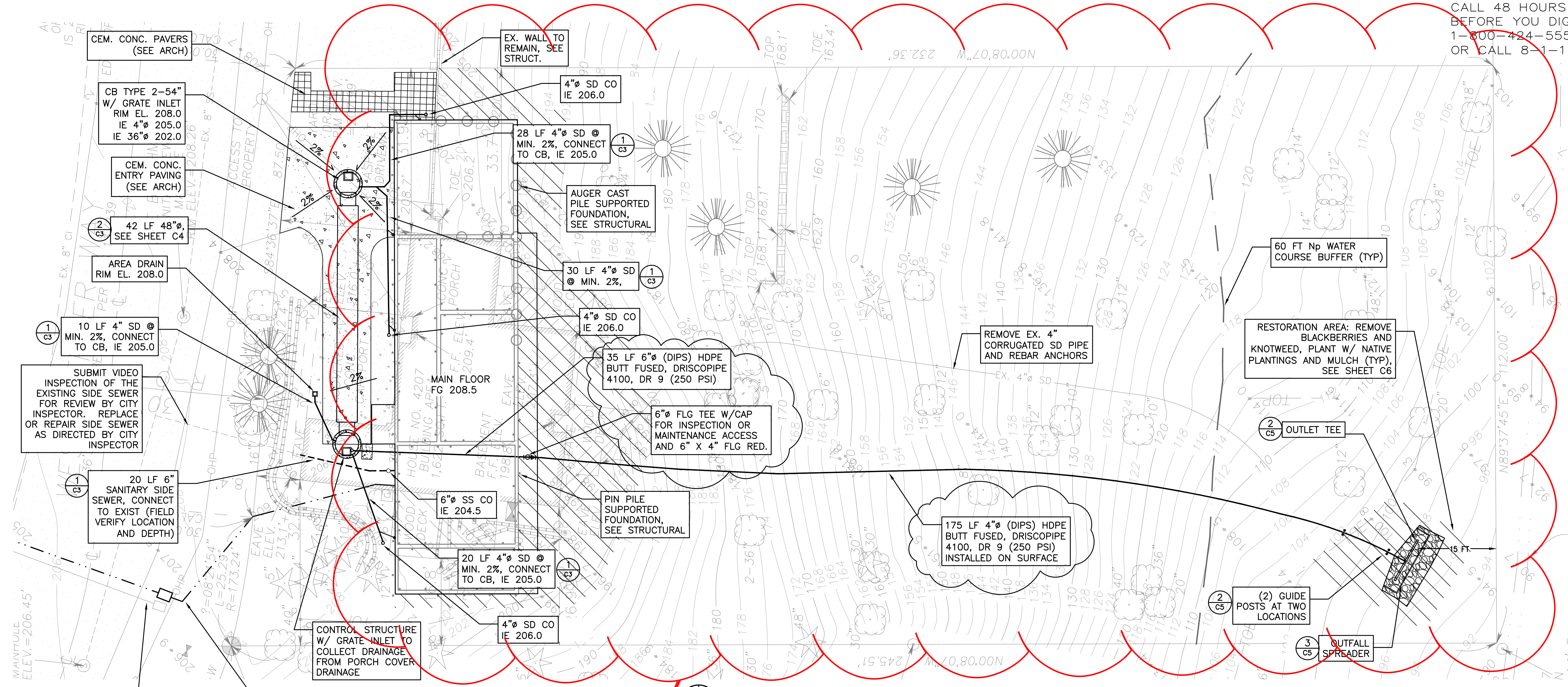

WORK TO BE COMPLETED DURING FOUNDATION - ALL CIVIL WORK FROM NORTH FACE OF FOUNDATION TO BOTTOM OF RAVINE.

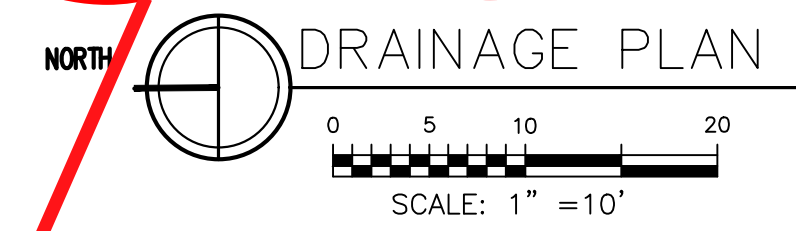

DETENTION TANK CONSTRUCTION SEQUENCING NOTES:

1. DETENTION TANK AND ASSOCIATED STRUCTURES SHALL BE INSTALLED ONLY AFTER PIN PILE AND AUGER CAST FOUNDATIONS ARE COMPLETE.
2. EXCAVATION FOR DETENTION TANK SHALL BE A SINGLE VERTICAL WALL TRENCH WITH TEMPORARY SHORING AND SAFETY SYSTEMS AS REQUIRED.
3. THE DETENTION TANK SHALL BE LOWERED INTO PLACE AND BACKFILLED AS INDICATED. EXCESS SPOILS SHALL BE REMOVED FROM THE SITE IMMEDIATELY.
4. HEAVY EQUIPMENT OR MACHINERY SHALL NOT ACCESS THE STEEP SLOPE BELOW THE HOUSE. THE STORM DRAIN PIPING AND OUTFALL WORK BELOW THE HOUSE SHALL BE BY HAND WORK AND PORTABLE TOOLS WITH FOOT ACCESS NOT HEAVY EQUIPMENT.

LEGEND

	AREA DRAIN
	CATCH BASIN, TYPE 2-54"
	CLEAN OUT
	DOWNSPOUT CONNECTION
	FOUNDATION DRAIN
	FOUNDATION DRAIN CLEANOUT
	PROPANE
	SANITARY SIDE SEWER
	STORM DRAIN
	WATER SERVICE

CONSTRUCTION NOTES:

1. FURNISH AND INSTALL ALL TRANSITION COUPLINGS (FERNCO REDUCERS AND COUPLINGS) AS NEEDED FOR CONNECTIONS TO BLDG UTILITIES
2. INVERT ELEVATIONS ARE APPROXIMATE. ADJUST INVERT ELEVATIONS AS NEEDED TO COORDINATE WITH BLDG UTILITIES AND EXISTING GRADES.
3. SEE ARCHITECTURE PLANS FOR BUILDING AND SITE FURNISHINGS DETAILS.

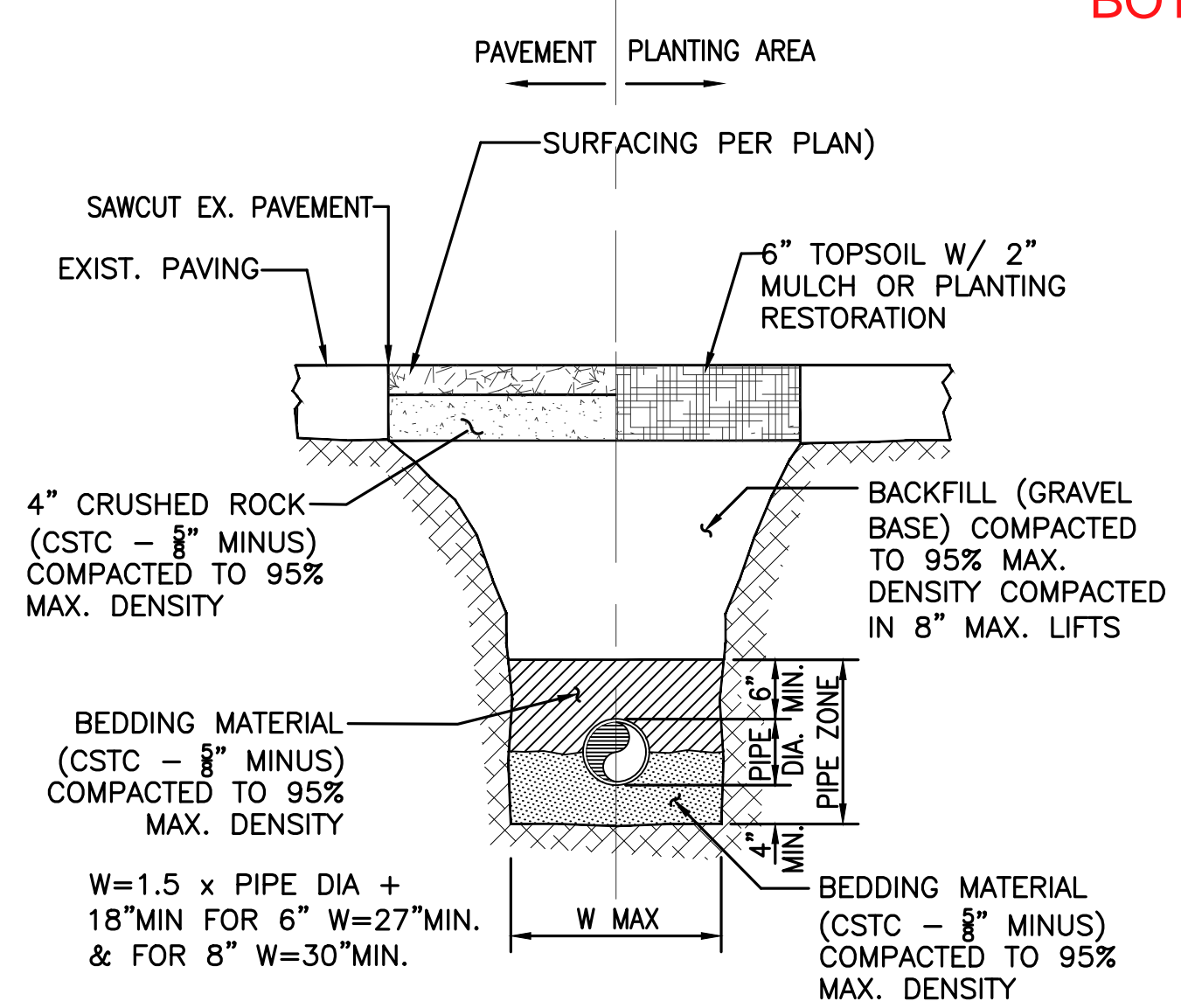

1 UTILITY TRENCH DETAIL
NTS

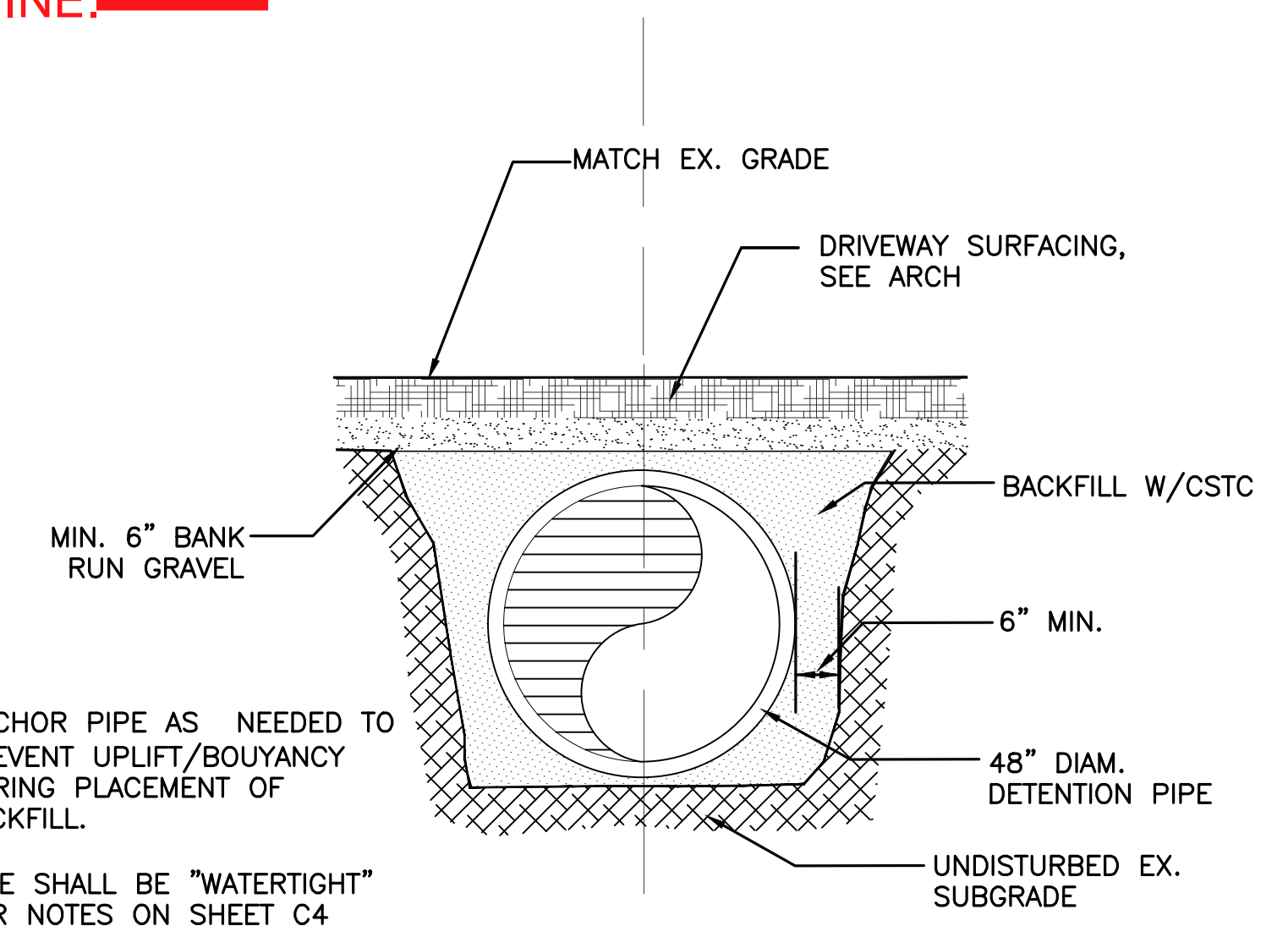

2 DETENTION PIPE DETAIL
NTS

- NOTE:**
1. ANCHOR PIPE AS NEEDED TO PREVENT UPLIFT/BOUYANCY DURING PLACEMENT OF BACKFILL.
 2. PIPE SHALL BE "WATERTIGHT" PER NOTES ON SHEET C4

Date:
5/21/20 Permit Set
8/19/20 Permit Rev.
9/16/20 Seasonal Waiver Rev.
9/22/20 Permit Rev.

Scale: 1" = 10'
Sheet: **3 of 6**

NOTE: SEE ADDITIONAL DETENTION PIPE DETAILS SHEET C4

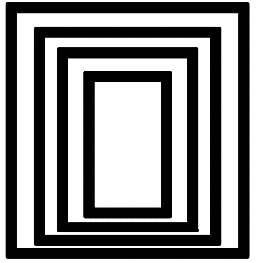

Civil Engineer:
WR Consulting, Inc.
3611 45th Ave W.
Seattle, WA 98199
P: 206.285.1593



VANEY / SHINDE
New Residence
4207 West Mercer Way
Mercer Island, WA 98040

ATTACHMENT 1
CITY OF MERCER ISLAND
ON-SITE DETENTION SYSTEM WORKSHEET
(FOR NEW PLUS REPLACED IMPERVIOUS
AREA OF 9,500 SF OR LESS)

NOTE:

1. THE DETENTION PIPE MATERIAL SHALL BE WATERTIGHT AS OPPOSED TO "SOIL TIGHT".
2. THE PIPE MATERIAL SELECTED SHALL CONFORM TO THE TESTING REQUIREMENTS IN SECTION 7-17.3(2)F OF THE 2020 WSDOT STANDARD SPECIFICATIONS EXCEPT THE DETENTION PIPE SHALL BE TESTED IN ITS ENTIRETY RATHER THAN ONE JOINT AT A TIME.

OWNER: PASHMI VANEY & RAHUL SHINDE	ADDRESS: 4207 WEST MERCER WAY	PREPARED BY: JOHN W. RUNDALL, P.E.
PERMIT #:	MERCER ISLAND, WA	PHONE: 206-850-1686
		DATE: May 19, 2020
NEW PLUS REPLACED IMPERVIOUS SURFACE AREA (SF): 3,485 SF	DETENTION PIPE DIA (INCH): 48" ϕ	DETENTION PIPE LENGTH (FT): 42
SOIL TYPE: TYPE C	PIPE MATERIAL: CORRUG. OR SPIRAL AL PIPE	ORIFICE #1 DIA 0.5 INCH, ELEV 200.0
		ORIFICE #2 DIA 1.30 INCH, ELEV 204.9

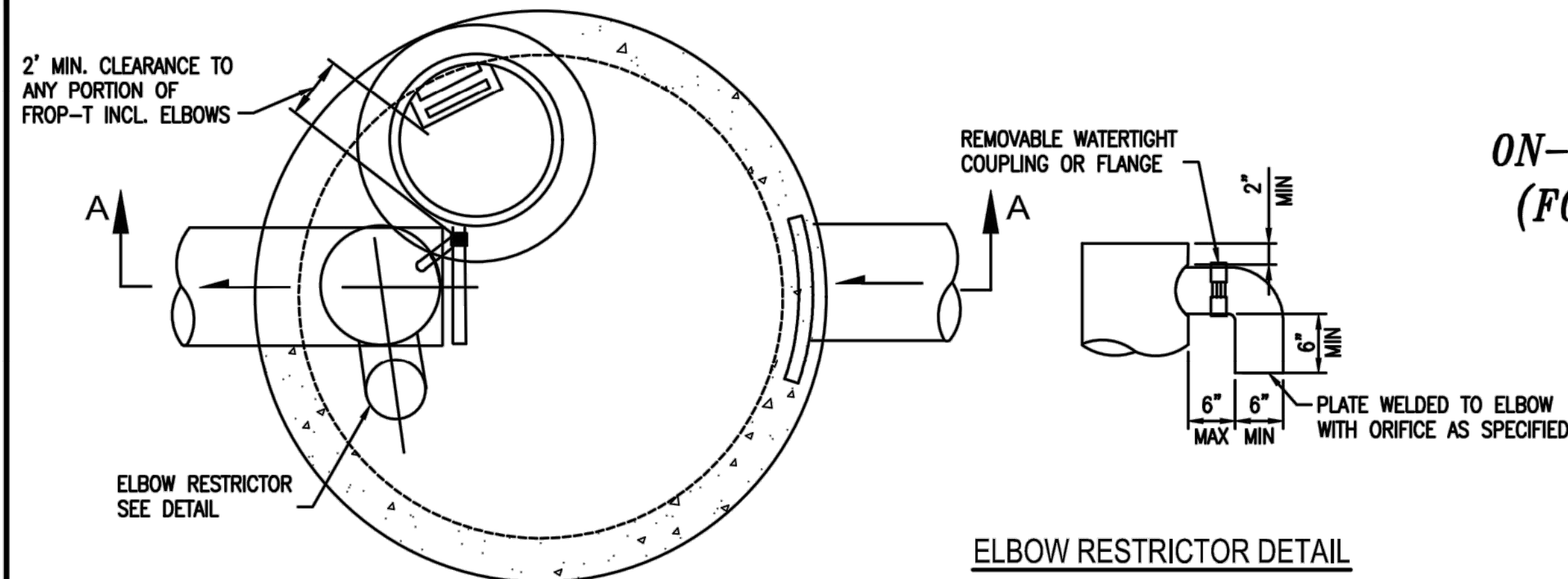

ELBOW RESTRICTOR DETAIL

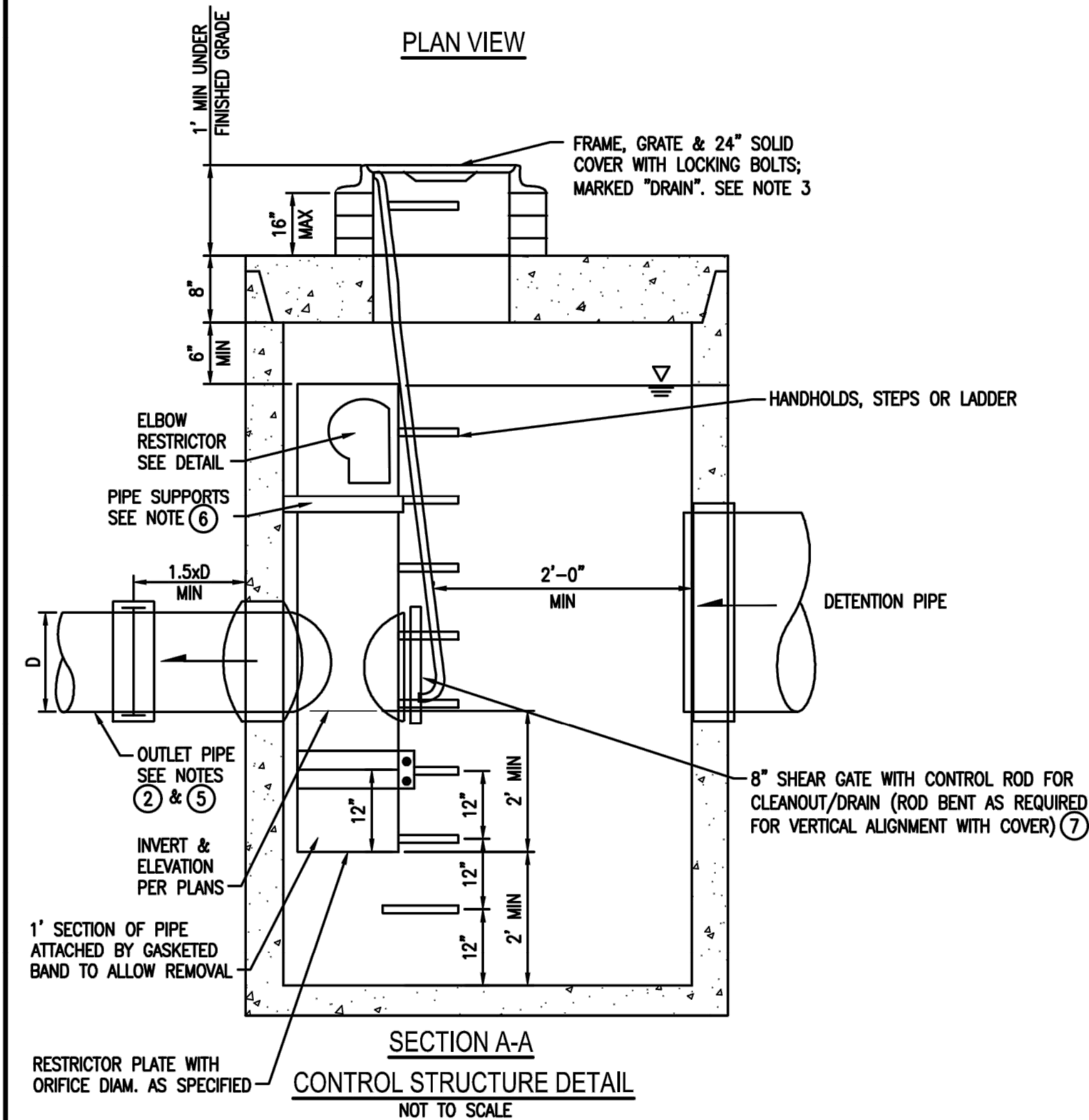

SECTION A-A
CONTROL STRUCTURE DETAIL
NOT TO SCALE

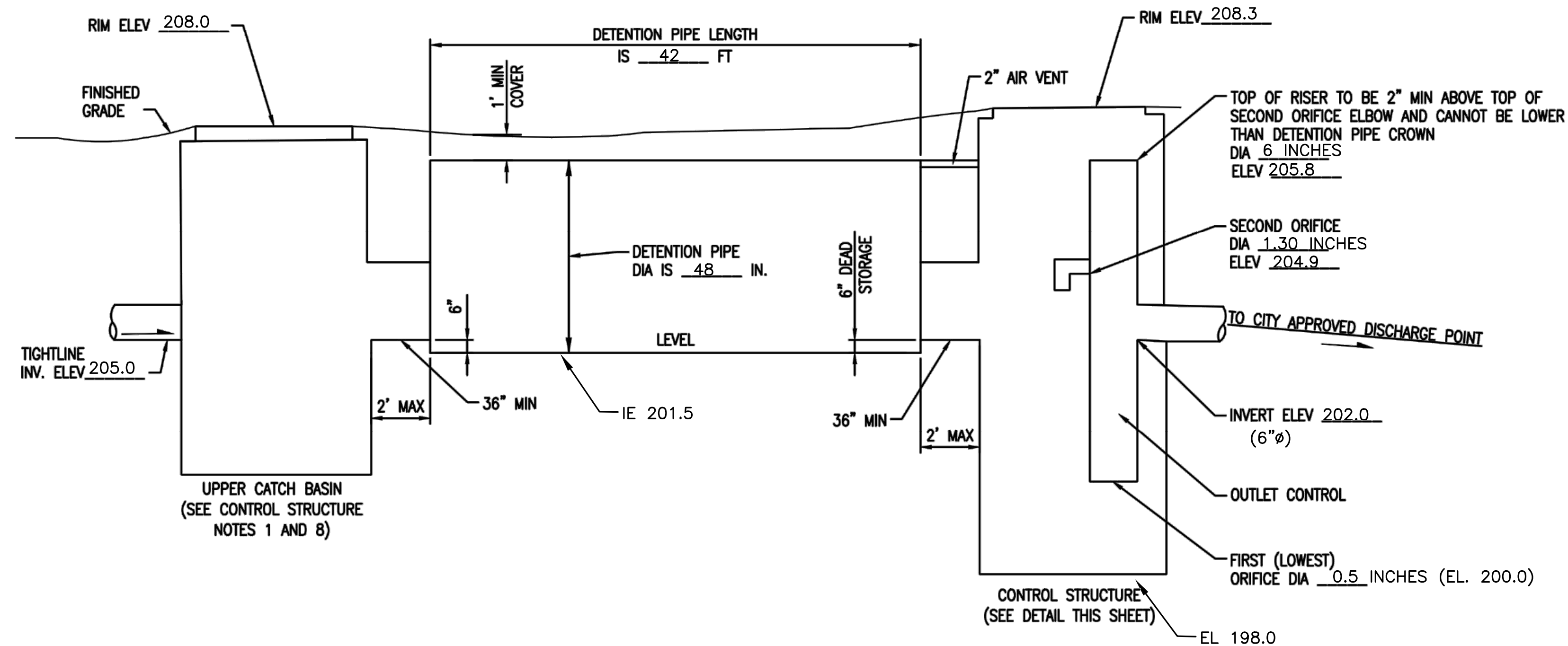

ON-SITE DETENTION SYSTEM
NOT TO SCALE (ENGINEER TO FILL IN BLANKS)

CONTROL STRUCTURE NOTES:

1. USE A MINIMUM OF A 54 IN. DIAM. TYPE 2 CATCH BASIN. THE ACTUAL SIZE IS DEPENDENT ON CONNECTING PIPE MATERIAL AND DIAMETER.
2. OUTLET PIPE: MIN. 6 INCH.
3. METAL PARTS: CORROSION RESISTANT. NON-GALVANIZED PARTS PREFERRED. GALVANIZED PIPE PARTS TO HAVE ASPHALT TREATMENT 1.
4. FRAME AND LADDER OR STEPS OFFSET SO:
 - A. CLEANOUT GATE IS VISIBLE FROM TOP;
 - B. CLIMB-DOWN SPACE IS CLEAR OF RISER AND CLEANOUT GATE;
 - C. FRAME IS CLEAR OF CURB.
5. IF METAL OUTLET PIPE CONNECTS TO CEMENT CONCRETE PIPE, OUTLET PIPE TO HAVE SMOOTH O.D. EQUAL TO CONCRETE PIPE I.D. LESS 1/4 IN.

6. PROVIDE AT LEAST ONE 3 X 0.090 GAUGE SUPPORT BRACKET ANCHORED TO CONCRETE WALL WITH 5/8 IN. STAINLESS STEEL EXPANSION BOLTS OR EMBEDDED SUPPORTS 2 IN. INTO CATCH BASIN WALL (MAXIMUM 3'-0" VERTICAL SPACING).
7. THE SHEAR GATE SHALL BE MADE OF ALUMINUM ALLOY IN ACCORDANCE WITH ASTM B 26M AND ASTM B 275, DESIGNATION ZG32A; OR CAST IRON IN ACCORDANCE WITH ASTM A 48, CLASS 30B. THE LIFT HANDLE SHALL BE MADE OF A SIMILAR METAL TO THE GATE (TO PREVENT GALVANIC CORROSION), IT MAY BE OF SOLID ROD OR HOLLOW TUBING, WITH ADJUSTABLE HOOK AS REQUIRED. A NEOPRENE RUBBER GASKET IS REQUIRED BETWEEN THE RISER MOUNTING FLANGE AND THE GATE FLANGE. INSTALL THE GATE SO THAT THE LEVEL-LINE MARK IS LEVEL WHEN THE GATE IS CLOSED. THE MATING SURFACES OF THE LID AND THE BODY SHALL BE MACHINED FOR PROPER FIT. ALL SHEAR GATE BOLTS SHALL BE STAINLESS STEEL.
8. THE UPPER CATCH BASIN IS REQUIRED IF THE LENGTH OF THE DETENTION PIPE IS GREATER THAN 50 FT.

ON-SITE DETENTION SYSTEM NOTES:

1. CALL DEVELOPMENT SERVICES (206-275-7605) 24 HOURS IN ADVANCE FOR A DETENTION SYSTEM INSPECTION BEFORE BACKFILLING AND FOR FINAL INSPECTIONS.
2. RESPONSIBILITY FOR OPERATION AND MAINTENANCE OF DRAINAGE SYSTEMS ON PRIVATE PROPERTY IS RESPONSIBILITY OF THE PROPERTY OWNER. MATERIAL ACCUMULATED IN THE STORAGE PIPE MUST BE REMOVED FROM CATCH BASINS TO ALLOW PROPER OPERATION. THE OUTLET CONTROL ORIFICE MUST BE KEPT OPEN AT ALL TIMES.
3. PIPE MATERIAL, JOINT, AND PROTECTIVE TREATMENT SHALL BE IN ACCORDANCE WITH SECTION 7.04 AND 9.05 OF THE WSDOT STANDARD SPECIFICATION FOR ROAD, BRIDGE, AND MUNICIPAL CONSTRUCTION, LATEST VERSION. SUCH MATERIALS INCLUDE THE FOLLOWING, LINED CORRUGATED POLYETHYLENE PIPE (LCPE), ALUMINIZED TYPE 2 CORRUGATED STEEL PIPE AND PIPE ARCH (MEETS AASHTO DESIGNATIONS M274 AND M36), CORRUGATED OR SPIRAL RIB ALUMINUM PIPE, OR REINFORCED CONCRETE PIPE. CORRUGATED STEEL PIPE IS NOT ALLOWED.
4. FOOTING DRAINS SHALL NOT BE CONNECTED TO THE DETENTION SYSTEM.

Date:
5/21/20 Permit Set
8/19/20 Permit Rev.
9/16/20 Seasonal
9/22/20 Permit Rev.

Scale: As Noted

Sheet: 4 of 6

DETENTION
TANK DETAILS

C4

CALL 48 HOURS
BEFORE YOU DIG
1-800-424-5555
OR CALL 8-1-1

**Studio
Ectypos**
ARCHITECTURE

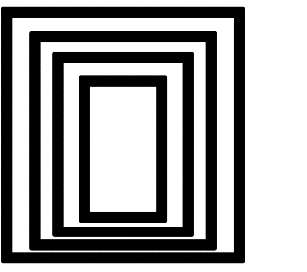

4212 W. Mercer Way
Mercer Island, WA 98040
t. (206)232-9147
www.studioectypos.com

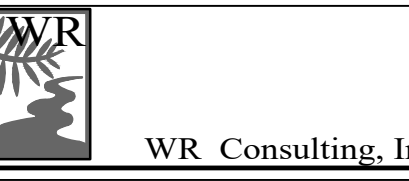

Civil Engineer:
WR Consulting, Inc.
3611 45th Ave W.
Seattle, WA 98199
P: 206.285.1593

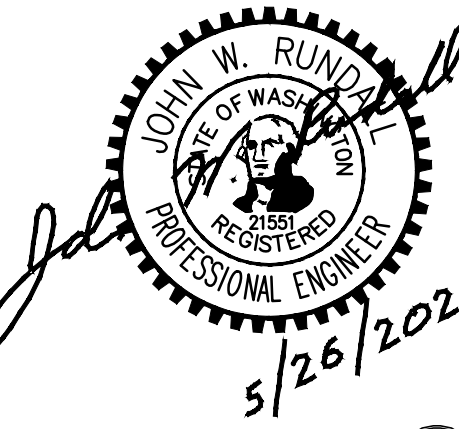

VANEY / SHINDE
New Residence
4207 West Mercer Way
Mercer Island, WA 98040

Date:
5/21/20 Permit Set
8/19/20 Permit Rev.
9/16/20 Seasonal
Waiver Rev.
9/22/20 Permit Rev.

Scale: As Noted
Sheet: 5 of 6

**DRAINAGE
DETAILS**

C5

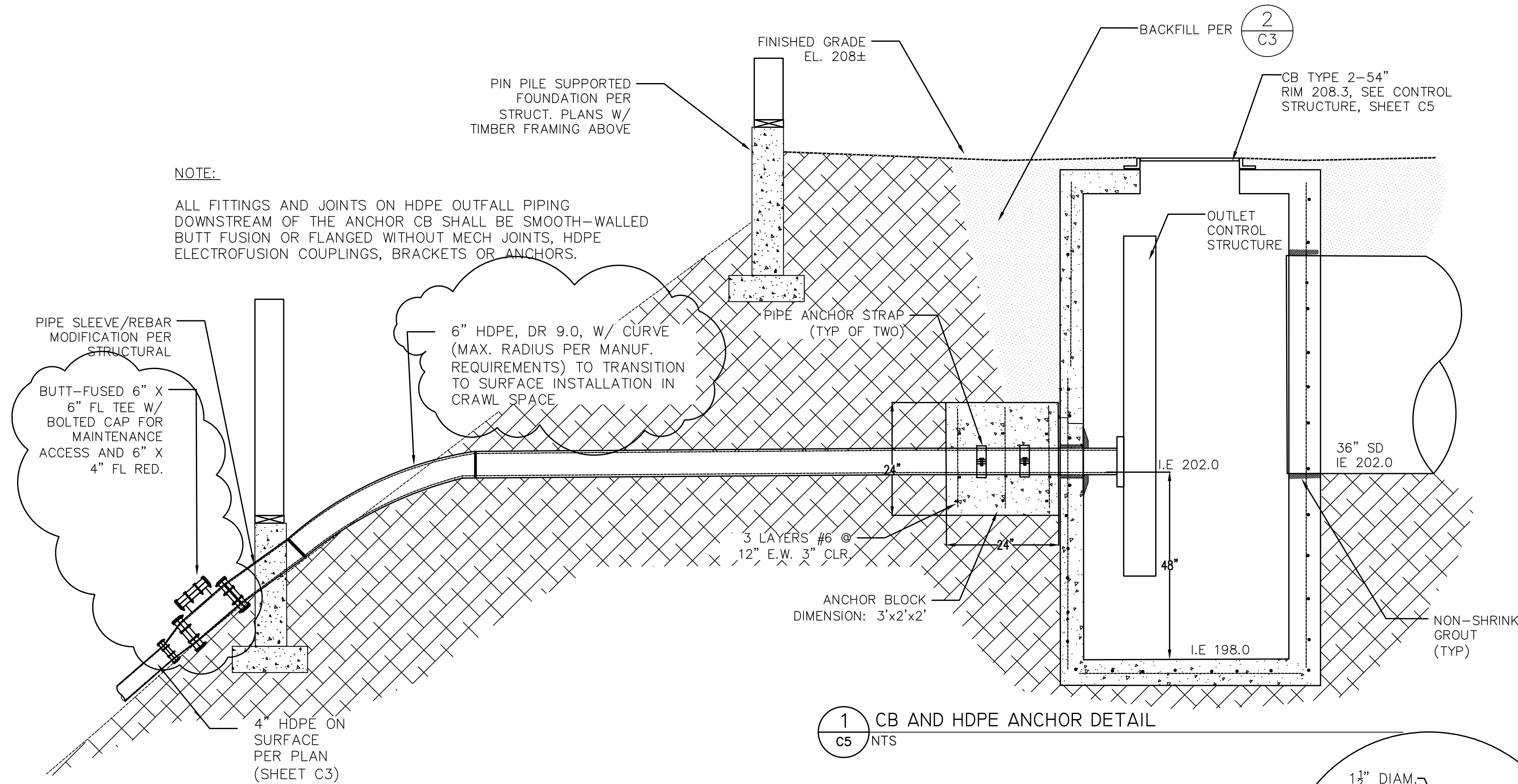

1
C5
NTS
CB AND HDPE ANCHOR DETAIL

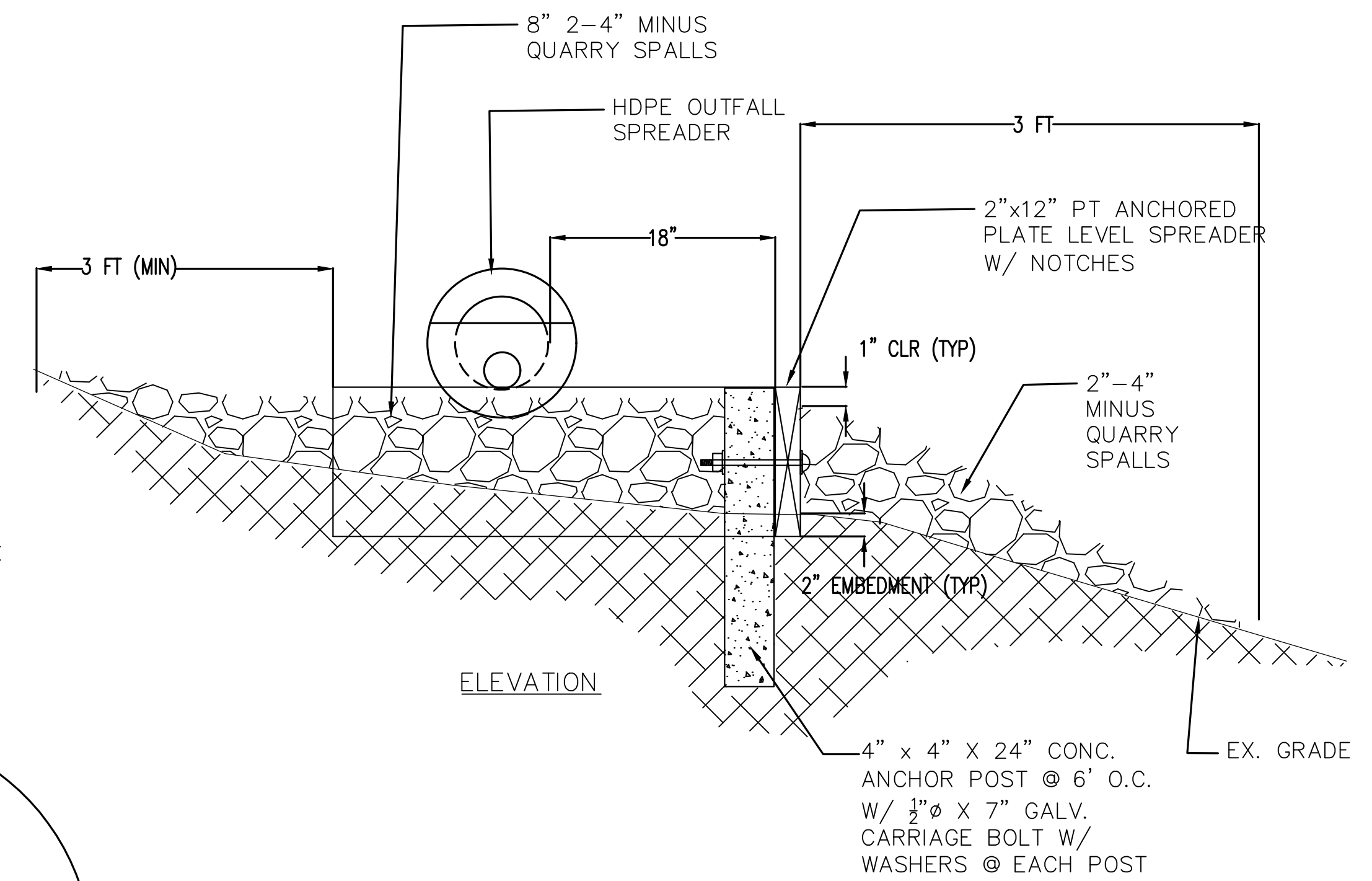

ELEVATION

HDPE OUTFALL NOTES:

1. NO TYPE OF ANCHORS SHALL BE USED ON THE SLOPE EXCEPT AT THE OUTLET/DISPERSAL TEE WHERE GUIDE POSTS ARE INDICATED. THE GUIDE POSTS SHALL NOT BE RIGIDLY COUPLED TO THE PIPE TO ALLOW THE PIPE TO MOVE AND FLOAT IF SOIL DEBRIS MOVES DOWNSLOPE FROM THE SLOPE ABOVE.
2. ALL FITTINGS AND JOINTS ON HDPE OUTFALL PIPING DOWNSTREAM OF THE ANCHOR CB SHALL BE SMOOTH-WALLED BUTT FUSION WITHOUT FLANGES JOINTS, HDPE ELECTROFUSION COUPLINGS, BRACKETS OR ANCHORS.

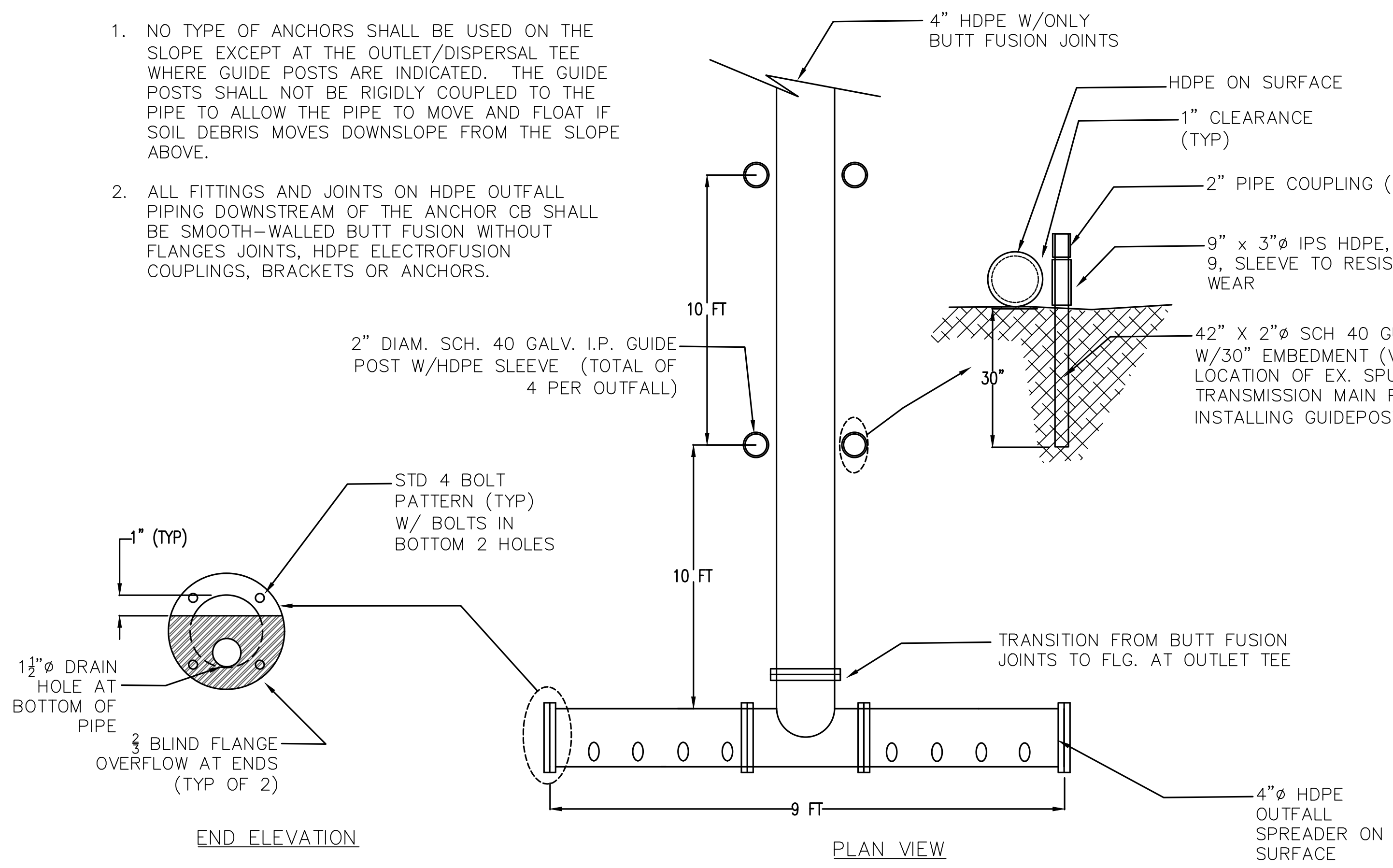

END ELEVATION

PLAN VIEW

2
C5
NTS
HDPE OUTFALL TEE DETAIL

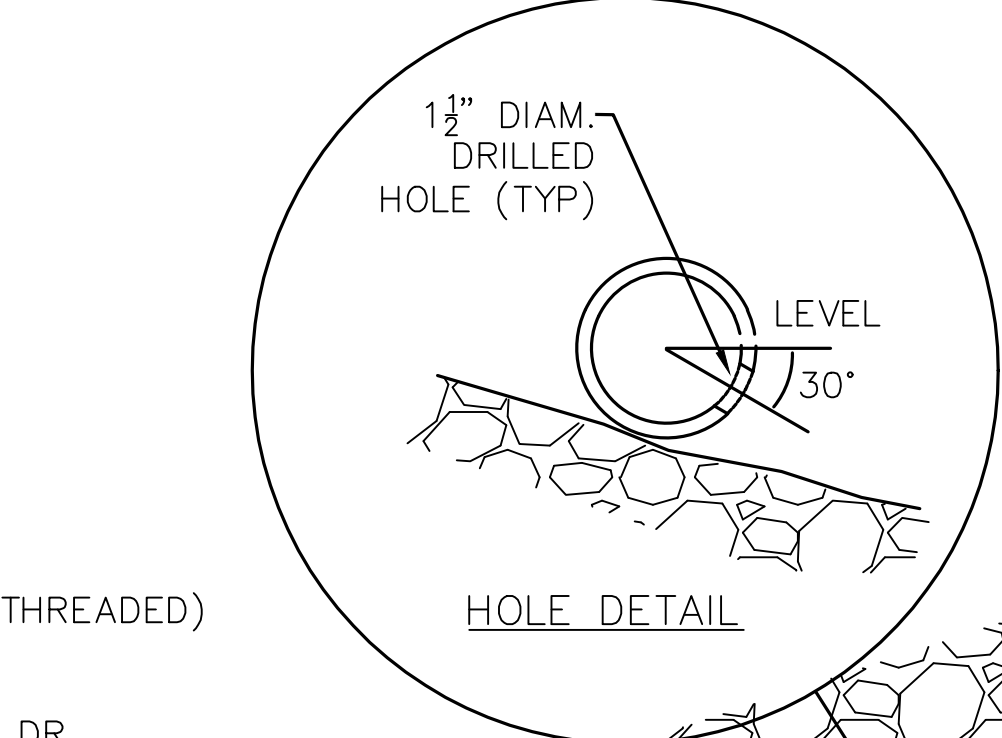

HOLE DETAIL

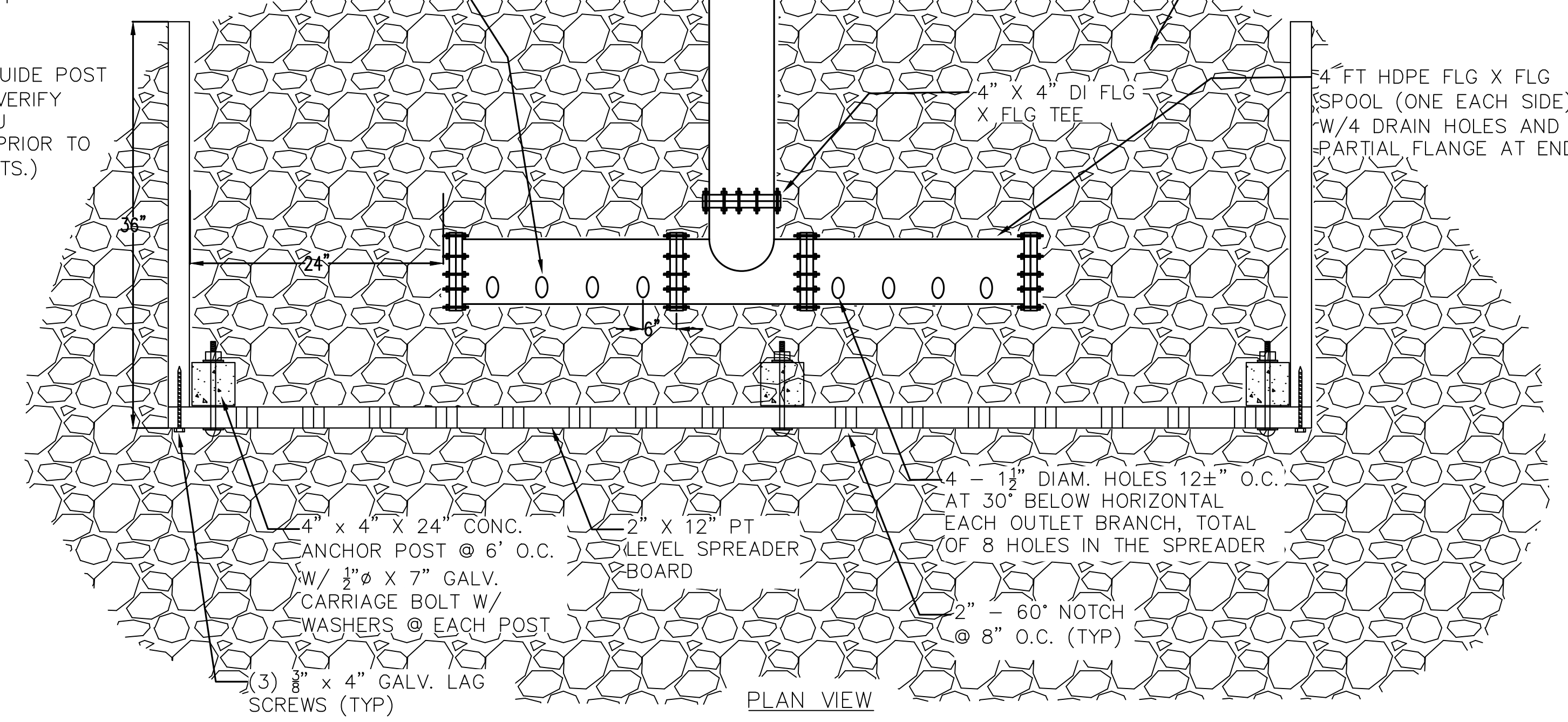

PLAN VIEW

3
C5
NTS
HDPE SPREADER OUTLET TEE DETAIL

NOTE: SEE ADDITIONAL DETENTION PIPE DETAILS SHEET C4

CALL 48 HOURS BEFORE YOU DIG
1-800-424-5555
OR CALL 8-1-1

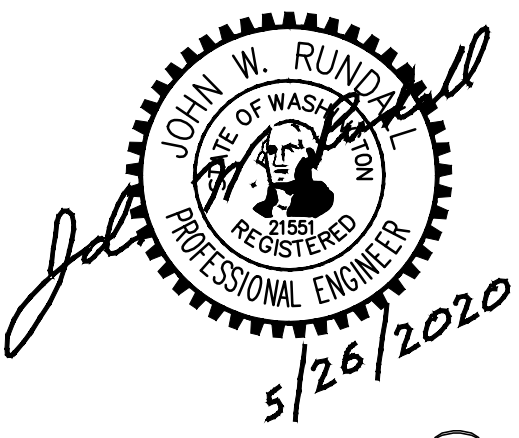

VANEY / SHINDE
New Residence
4207 West Mercer Way
Mercer Island, WA 98040

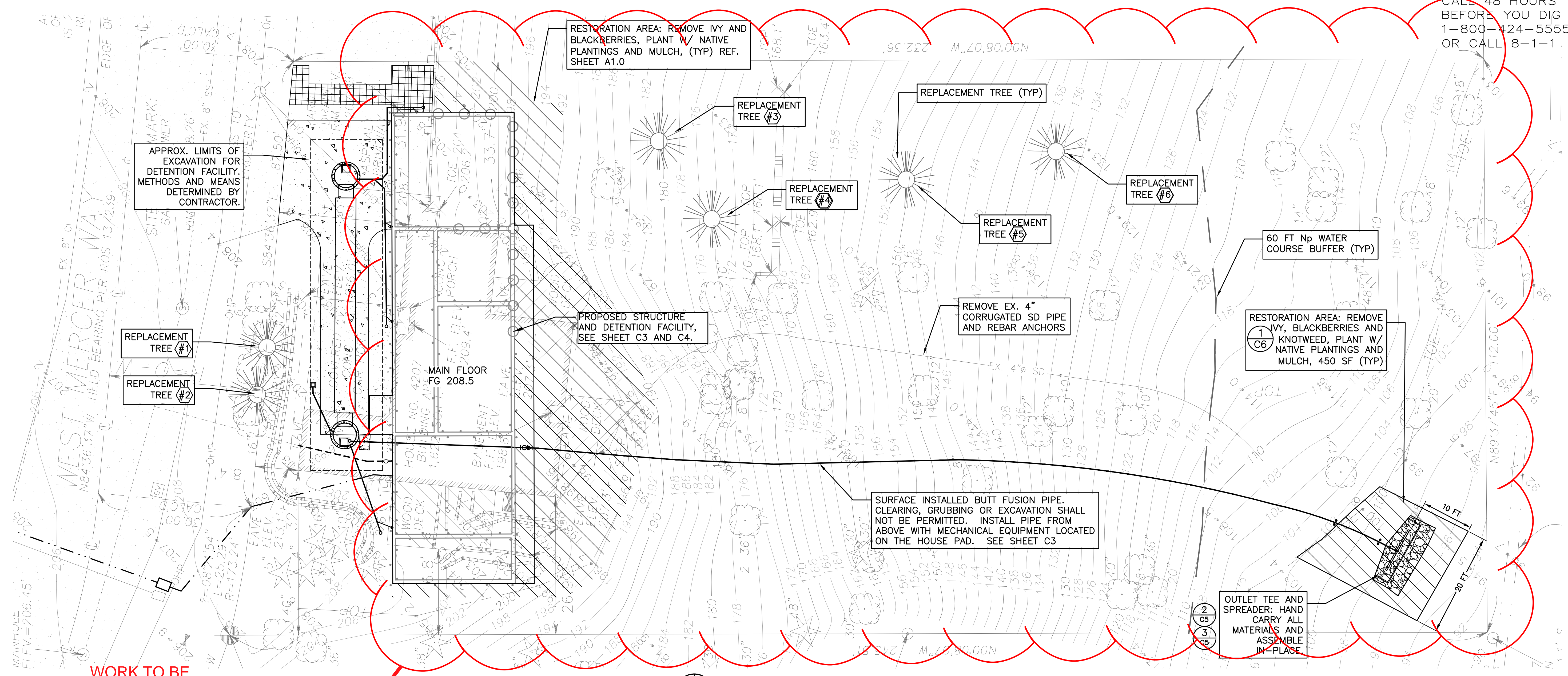

WORK TO BE COMPLETED DURING FOUNDATION - ALL CIVIL WORK FROM NORTH FACE OF FOUNDATION TO BOTTOM OF RAVINE.

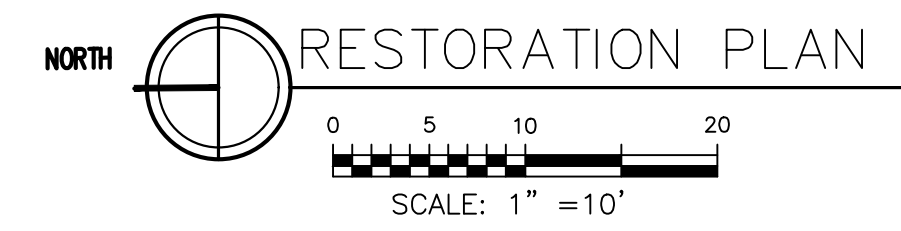

TREE REPLACEMENT SCHEDULE		
NUMBER	NAME/TYPE	HEIGHT
①	PACIFIC YEW (TAXIS BREVIFOLIA)	6 FT
②	PACIFIC YEW (TAXIS BREVIFOLIA)	6 FT
③	DOUGLAS FIR (PSEUDOTSUGA MENZIESII)	8-10 FT
④	SITKA SPRUCE (PICEA SITCHENSIS)	6 FT
⑤	DOUGLAS FIR (PSEUDOTSUGA MENZIESII)	8-10 FT
⑥	SITKA SPRUCE (PICEA SITCHENSIS)	6 FT

SOIL AND PLANTING NOTES:

- EXISTING INVASIVE WEEDS (PARTICULARLY HIMALAYAN BLACKBERRIES AND JAPANESE KNOTWEED) SHALL BE REMOVED IN THEIR ENTIRETY INCLUDING ROOTS (CORNS AND RHIZOMES).
- THE INVASIVE PLANT MATERIAL SHALL BE REMOVED FROM THE SITE AND DISPOSED OF IN ACCORDANCE WITH KING COUNTY NOXIOUS WEED CONTROL REQUIREMENTS.
- PRIOR TO PLANTING, THE SOIL SHALL BE SCARIFIED AND COVERED WITH A MINIMUM OF 6" OF ARBORISTS MULCH.
- PLANTINGS SHALL BE MINIMUM 1 GALLON.
- PLANTS SHALL BE SPACED AT 30" O.C., TRIANGULAR SPACING.
- PLANTINGS SHALL BE A RANDOM DISTRIBUTION OF A MIX OF THE PLANTS INDICATED ON THE PLANT LIST.

PLANT	COMMON NAME	QUANTITY
1. CORNUS STOLONIFERA	REDTWIG DOGWOOD	12
2. LONICERA INVOLUCRATA	TWINBERRY	12
3. PHILADELPHUS LEWISII	MOCK-ORANGE	12
4. RIBES SANGUINEUM	RED FLOWERING CURRRANT	12
5. ROSA NUTKANA	NOOTKA ROSE	12
6. RUBUS PARVIFLORA	THIMBLEBERRY	12
7. RUBUS SPECTABILIS	SALMONBERRY	12

LEGEND	
	AREA DRAIN
	CATCH BASIN, TYPE 2-54"
	CLEAN OUT
	DOWNSPOUT CONNECTION
	FOUNDATION DRAIN
	FOUNDATION DRAIN CLEANOUT
	PROPANE
	SANITARY SIDE SEWER
	STORM DRAIN
	WATER SERVICE

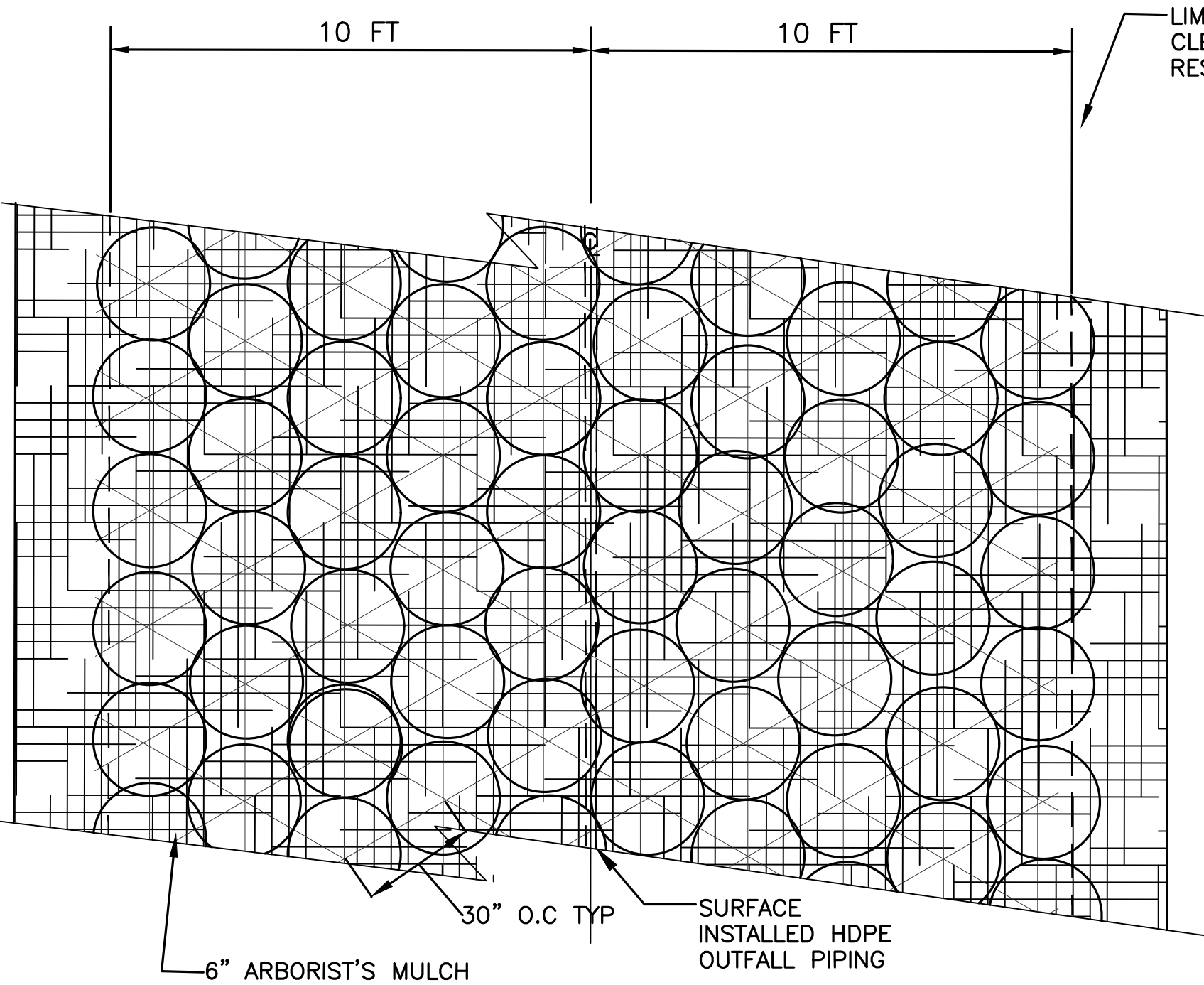
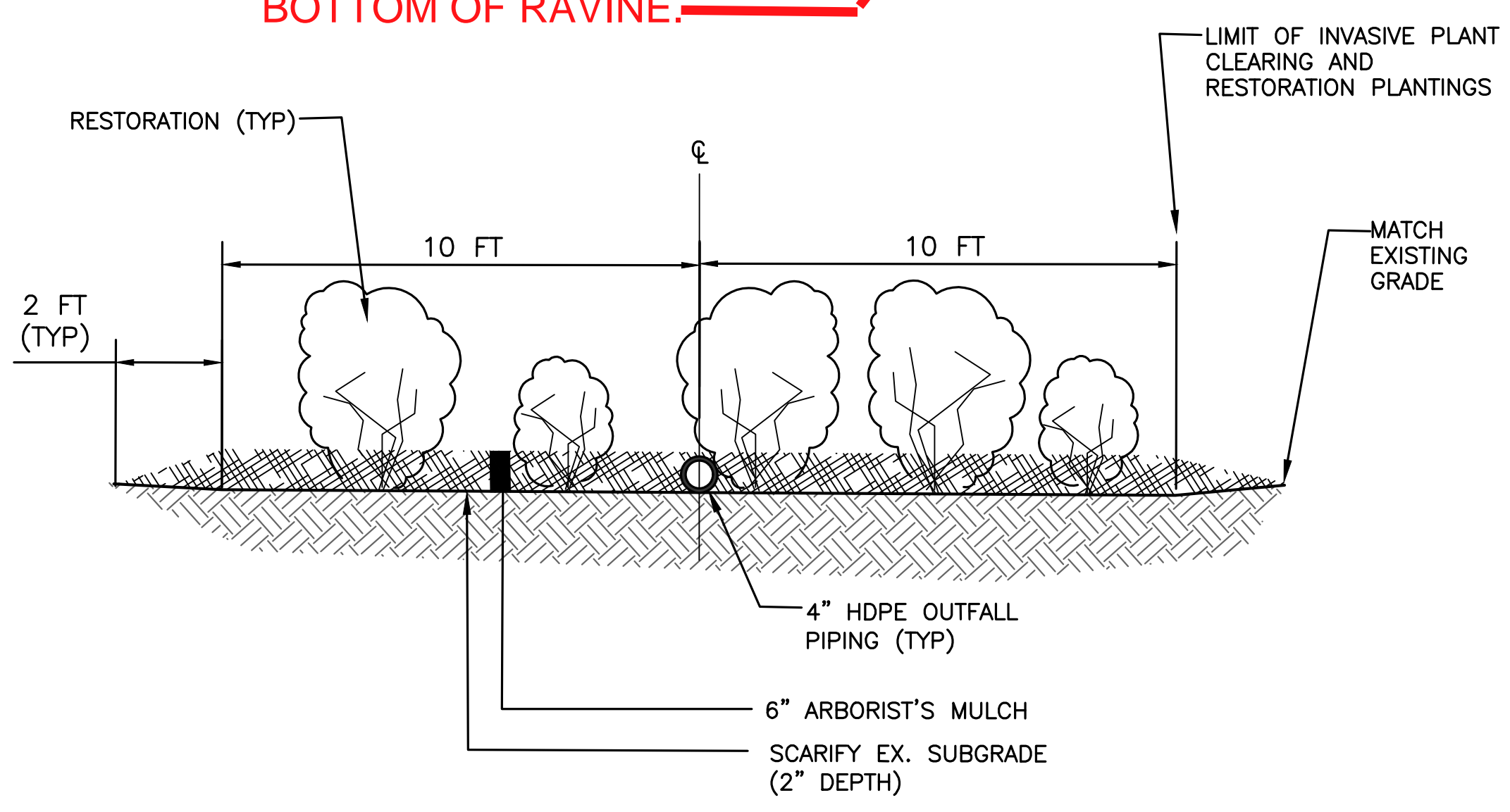

1 WATER COURSE BUFFER RESTORATION PLANTING PLAN
C6 NTS

Date:
5/21/20 Permit Set
8/19/20 Permit Rev.
9/16/20 Seasonal
Waiver Rev.
9/22/20 Permit Rev.

Scale: 1" = 10'
Sheet: 6 of 6

RESTORATION PLAN

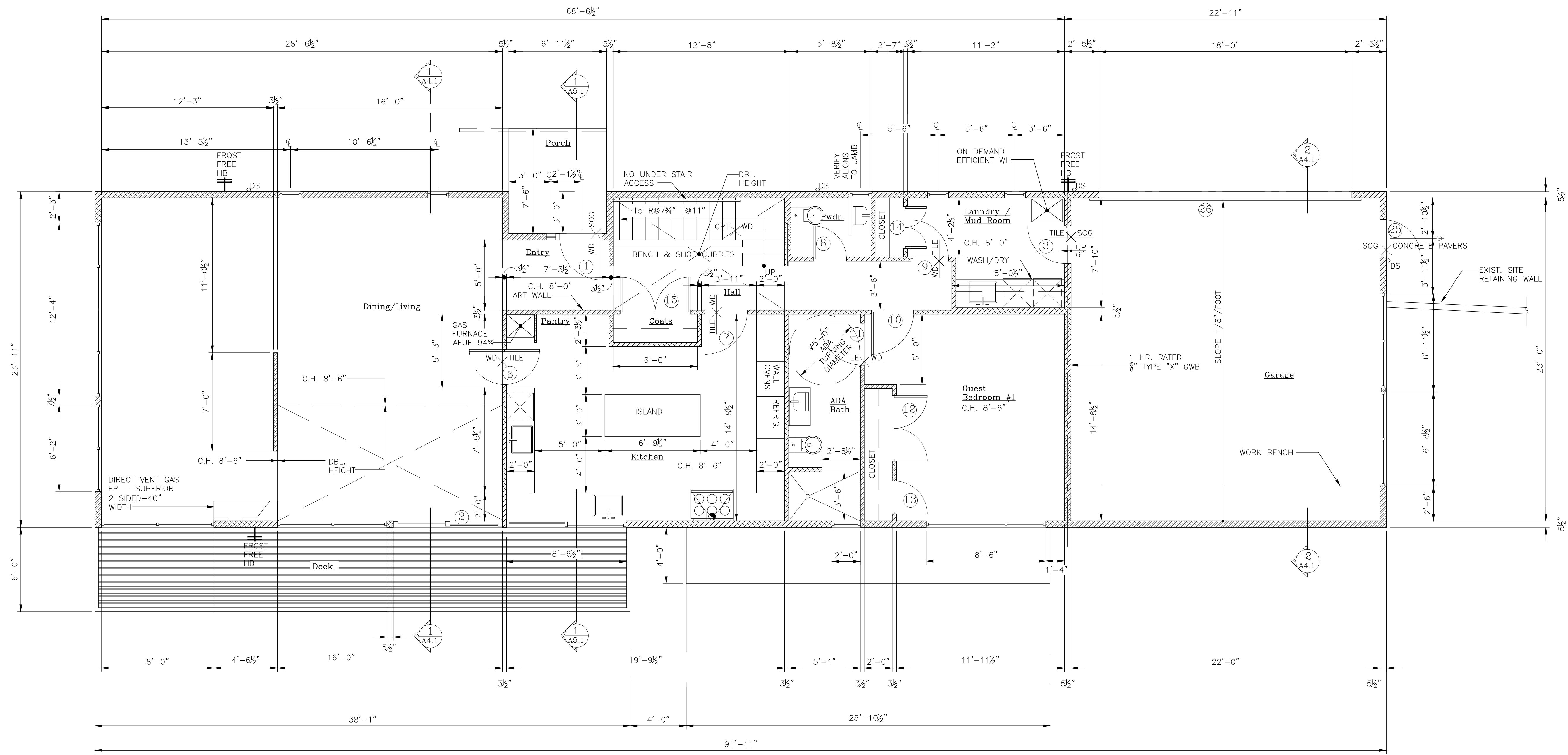

1 Main Floor Plan
scale: 1/4"=1'-0"

- PLAN NOTES:**
- SEE SHEET A0.1 GENERAL NOTES FOR PLAN NOTES IN COMMON
 - SEE SHEET A0.1 FOR REQUIRED DETAILED ENERGY EFFICIENCY CREDITS DESCRIPTIONS (EEC).
 - EEC 1a EFFICIENT BUILDING ENVELOPE**
 - EEC 2a AIR LEAKAGE CONTROL 3.0 AIR CHANGES PER HOUR**
 - EEC 3a HIGH EFFICIENCY HVAC EQUIPMENT - GAS FURNACE MINIMUM AFUE 94%**
 - EEC 4 HIGH EFFICIENCY DISTRIBUTION SYSTEM - ALL CONDITIONED AIR DISTRIBUTION INSIDE CONDITIONED SPACE.**
 - EEC 5a EFFICIENT WATER HEATING - PROVIDE MAX. FLOW RATES AS OUTLINED FOR THIS CREDIT.**
 - SEE SHEETS E2.1 & E2.2 FOR REQUIRED VENTILATION RATES
 - SEE SHEETS A3.1, A3.2, A4.1 AND A9.1 FOR EMERGENCY EGRESS LOCATIONS AND REQUIREMENTS.
 - SEE SHEETS A9.1 AND A9.2 FOR WINDOW AND DOOR SCHEDULES.
 - INSTALL GAS APPLIANCES IN BEDROOMS PER IRC G2406
 - CONTRACTOR SHALL VERIFY TO INSPECTOR ALL GUARDS AND RAILING SHALL BE CAPABLE OF RESISTING 200LB LOAD ON TOP RAIL ACTING IN ANY DIRECTION. SEE A0.1 GENERAL NOTE 23

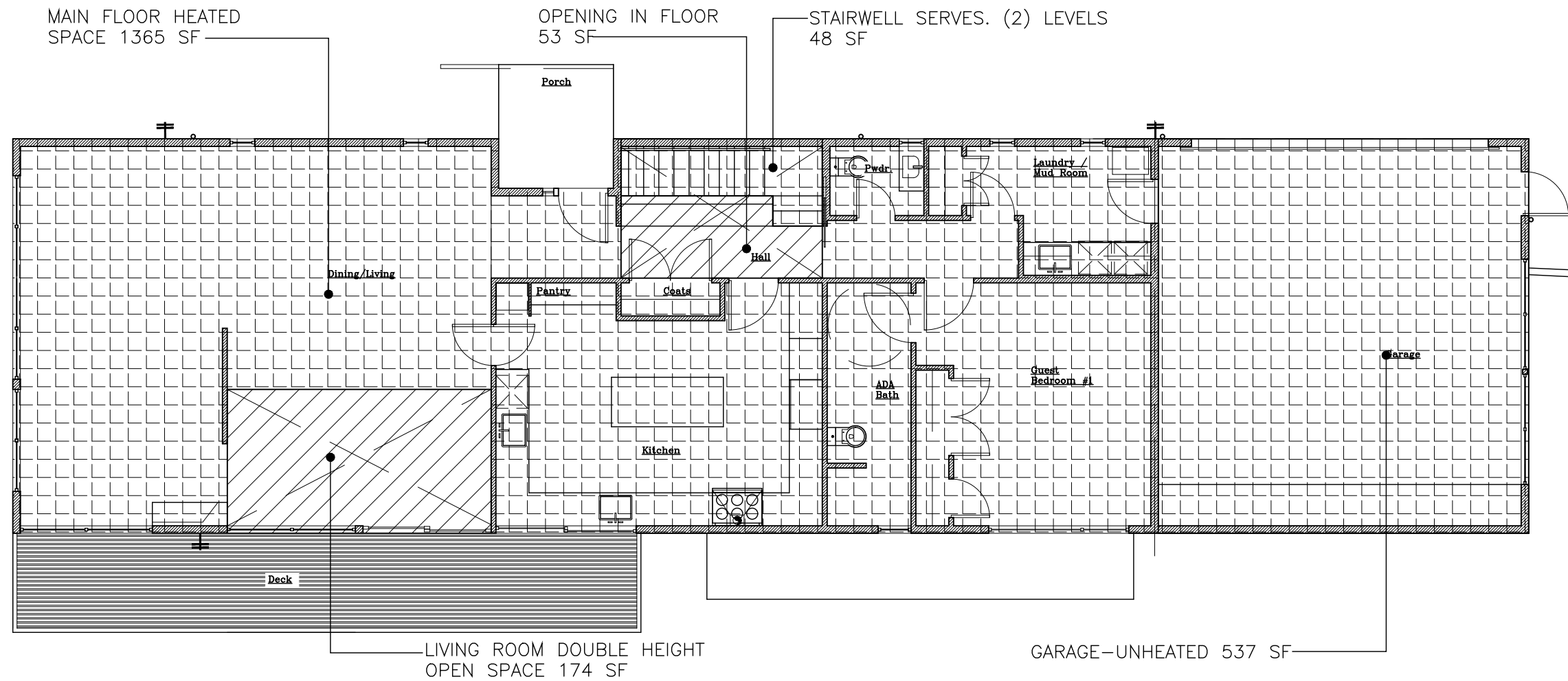

2 Main Floor GFA Detail
scale: 1/8"=1'-0"

GFA 100% = 1950 SF	
GFA 150% = -	
GFA 200% = 360 SF	
TOTAL MAIN FLOOR GFA = 2310 SF	

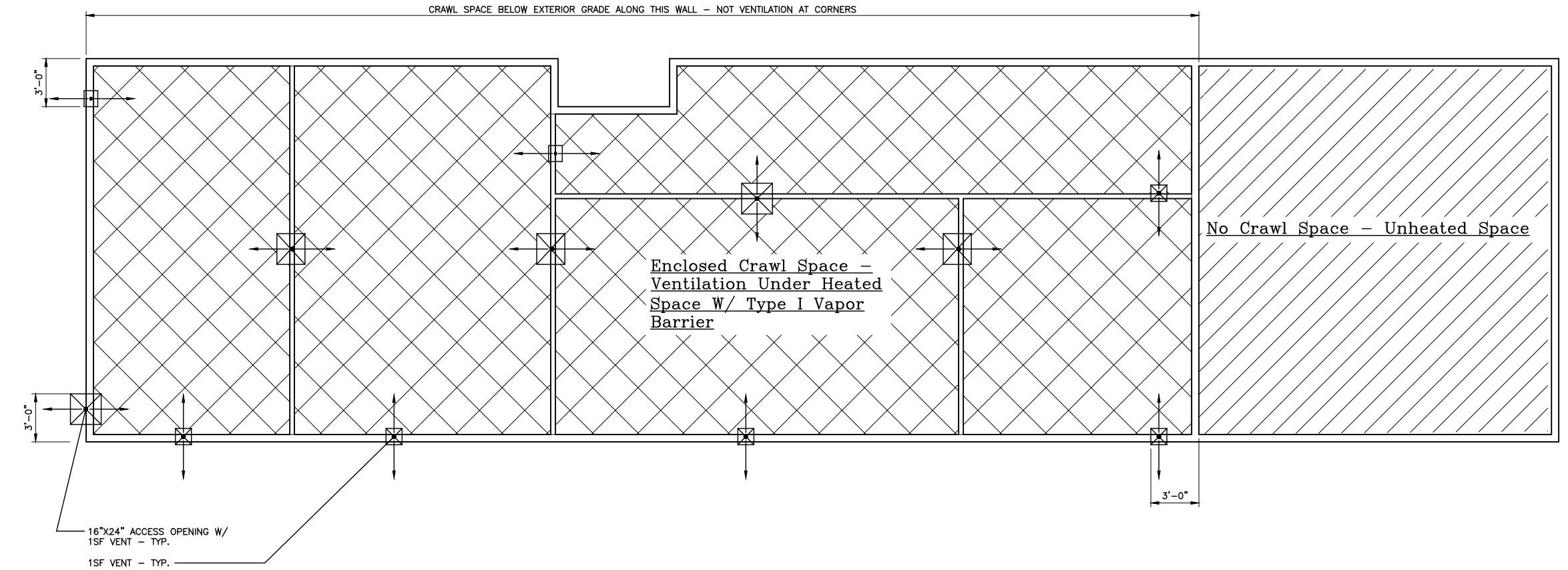

3 Crawl Space Vent Diagram
scale: 1/8"=1'-0"

Legend		Enclosed Crawl Space Ventilation Under Heated
NEW CRAWL SPACE W/ CLASS 1 VAPOR BARRIER 15F VENT PER/1500SF AREA		TOTAL AREA: 1552SF
NO-CRAWL SPACE-UNHEATED SPACE		VENTILATION REQUIRED PER 1500SF W/ CLASS 1 VAPOR BARRIER: 15F/1500SF
		REQUIRED VENTILATION: 1.03SF
		PROVIDED VENTILATION: 65F EXTERIOR VENTILATION + INTERIOR CROSS VENTILATION

Date:
5/27/20 Permit Sub
7/15/20 Early Comm ts
8/24/20 FND N PERMIT
9/8/20 FND N REVISION
10/30/20
Sub-2 2006-006

Scale:
Sheet:

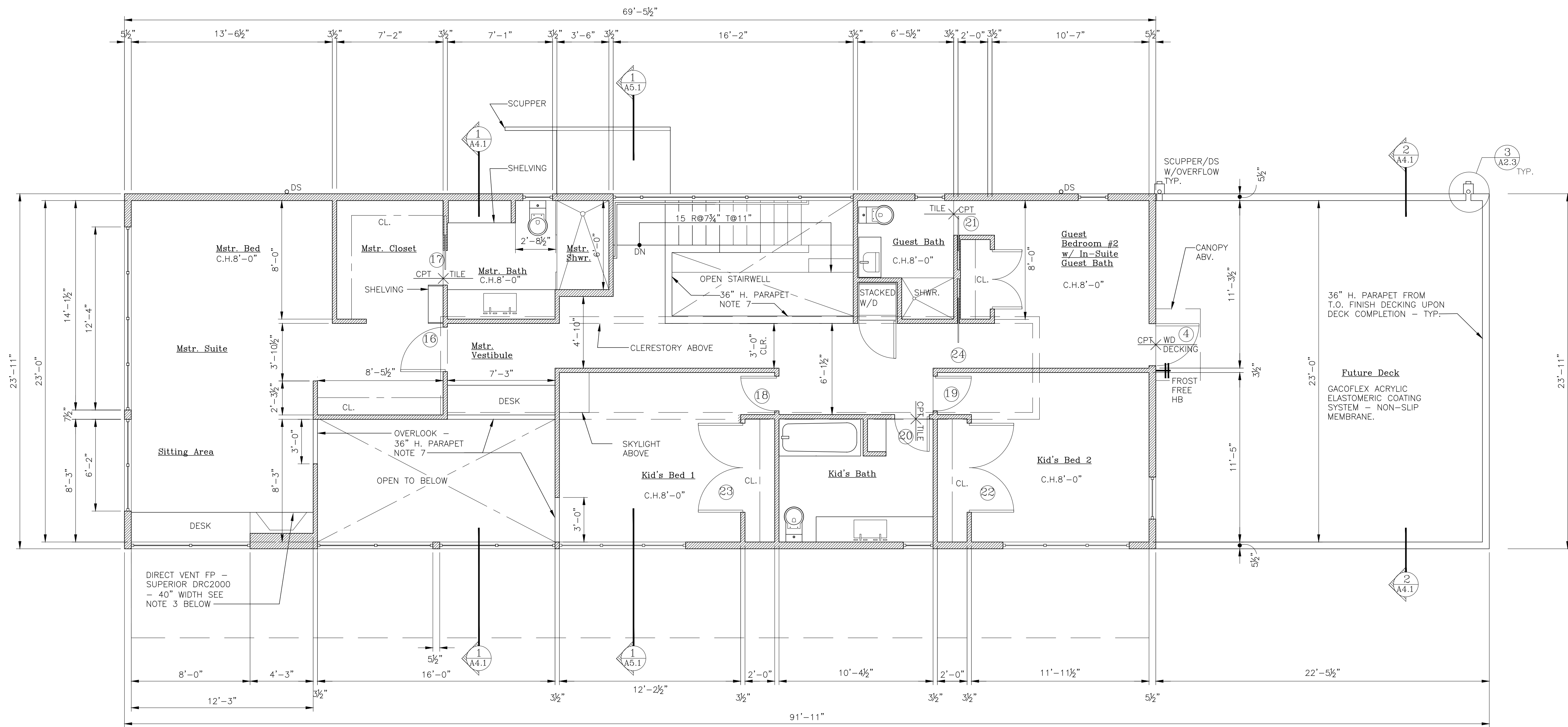

1 Upper Floor Plan
scale: 1/4"=1'-0"

PLAN NOTES:

- SEE SHEET A0.1 GENERAL NOTES FOR PLAN NOTES IN COMMON
- SEE SHEET A0.1 FOR REQUIRED DETAILED ENERGY EFFICIENCY CREDITS DESCRIPTIONS (EEC).
 - EEC 1a EFFICIENT BUILDING ENVELOPE
 - EEC 2a AIR LEAKAGE CONTROL 3.0 AIR CHANGES PER HOUR
 - EEC 3a HIGH EFFICIENCY HVAC EQUIPMENT - GAS FURNACE MINIMUM AFUE 94%
 - EEC 4 HIGH EFFICIENCY DISTRIBUTION SYSTEM - ALL CONDITIONED AIR DISTRIBUTION INSIDE CONDITIONED SPACE.
 - EEC 5a EFFICIENT WATER HEATING - PROVIDE MAX. FLOW RATES AS OUTLINED FOR THIS CREDIT.
- SEE SHEETS E2.1 & E2.2 FOR REQUIRED VENTILATION RATES
- SEE SHEETS A3.1, A3.2, A4.1 AND A9.1 FOR EMERGENCY EGRESS LOCATIONS AND REQUIREMENTS.
- SEE SHEETS A9.1 AND A9.2 FOR WINDOW AND DOOR SCHEDULES.
- INSTALL GAS APPLIANCES IN BEDROOMS PER IRC G2406
- CONTRACTOR SHALL VERIFY TO INSPECTOR ALL GUARDS AND RAILING SHALL BE CAPABLE OF RESISTING 200LB LOAD ON TOP RAIL ACTING IN ANY DIRECTION. SEE A0.1 GENERAL NOTE 23

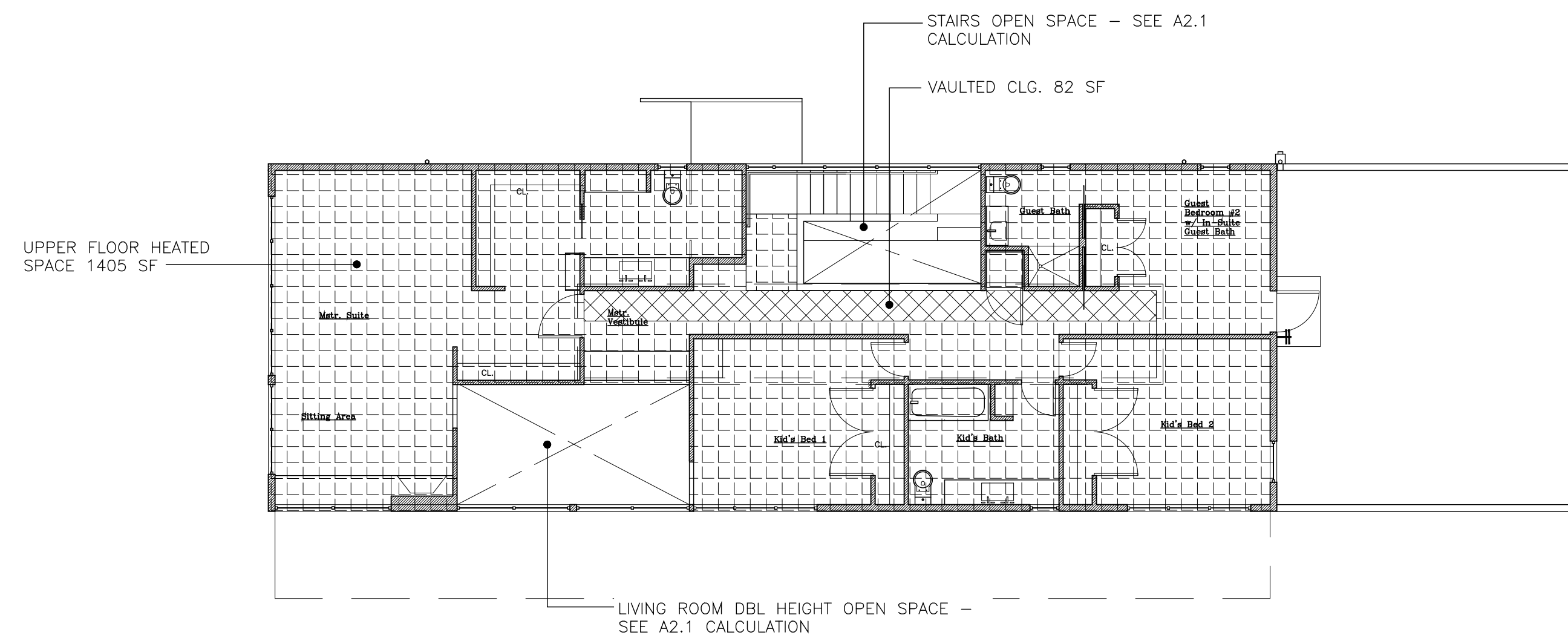

2 Upper Floor GFA Detail
scale: 1/8"=1'-0"

GFA 100% = 1405 SF	
GFA 150% = 123 SF	
GFA 200% = -	
TOTAL UPPER FLOOR GFA = 1528 SF	

Date:
5/27/20 Permit Sub
7/15/20 Early Com'n ts
8/24/20 FND'N PERMIT
9/8/20 FND'N REVISION
10/30/20
Sub-2 2006-006

Scale:
Sheet:

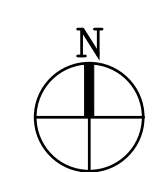
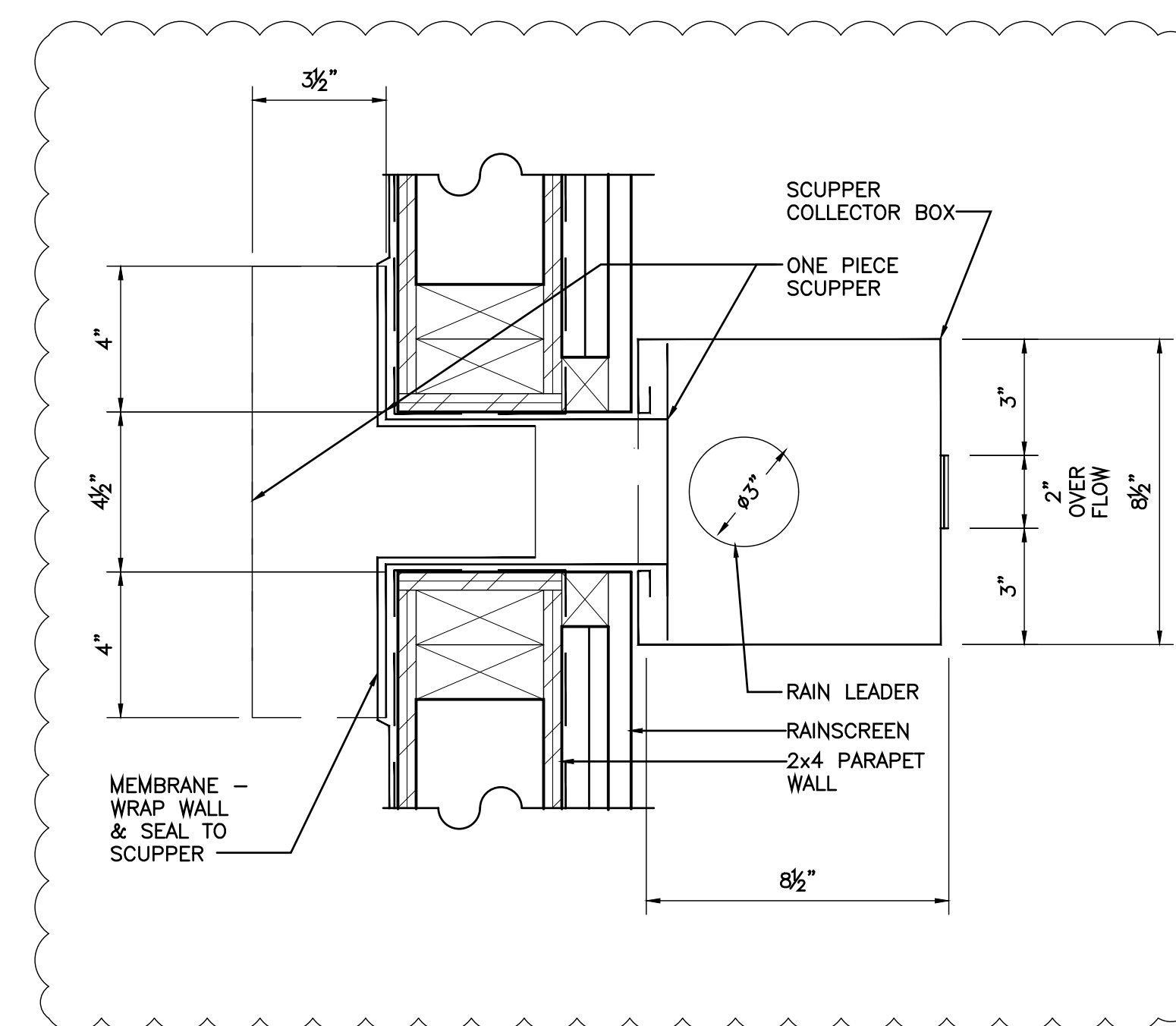
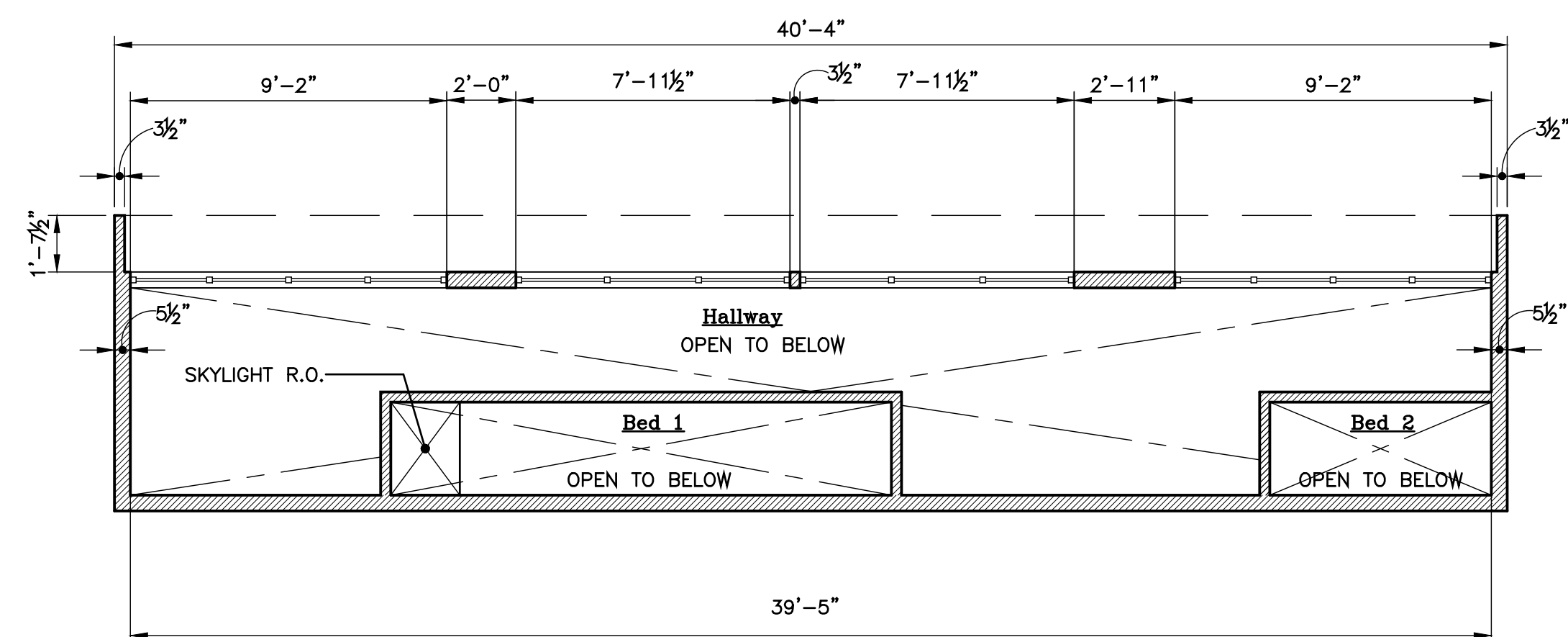

1 Clerestory Plan
scale: 1/4"=1'-0"

3 Typical Through Wall Scupper Detail
scale: 3/8"=1'-0"

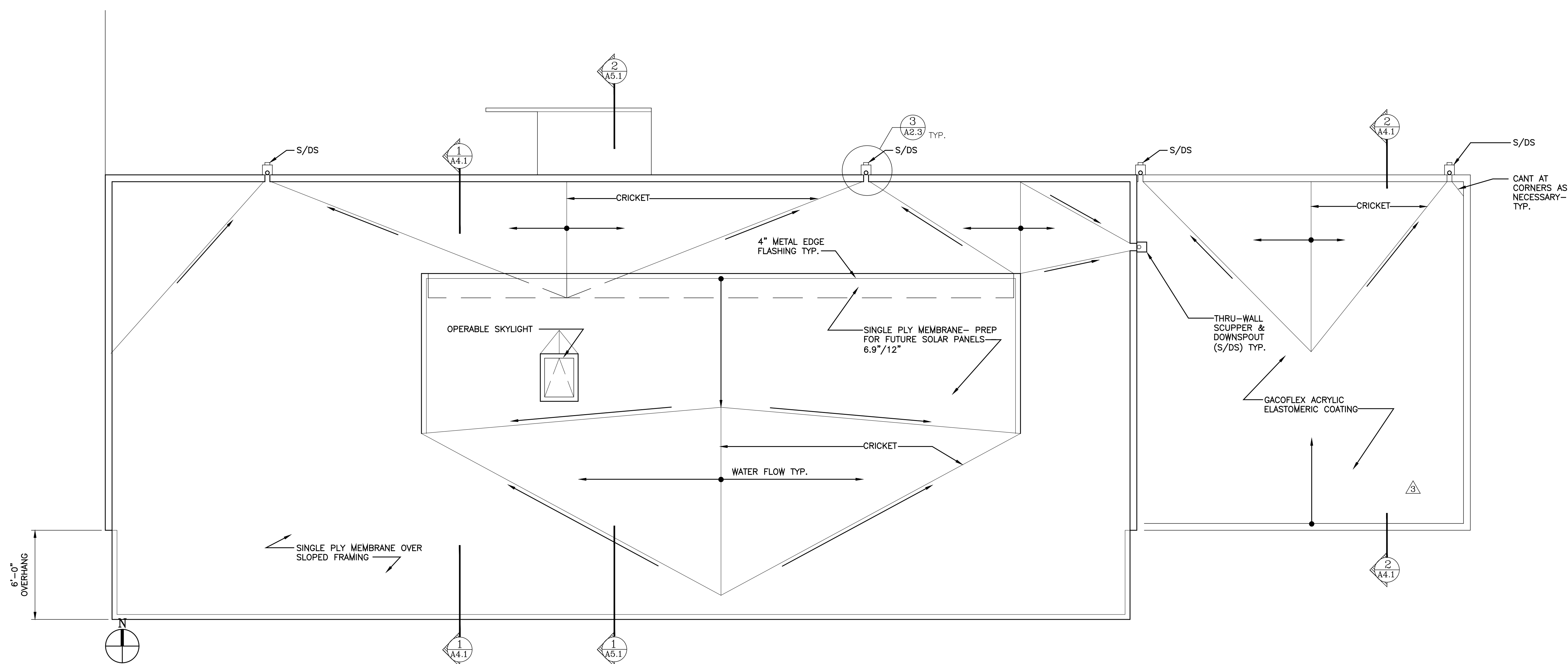

2 Roof Plan
scale: 1/4"=1'-0"

VANEY / SHINDE
New Residence
4207 West Mercer Way
Mercer Island, WA 98040

Date:
5/27/20 Permit Sub
7/15/20 Early Comm'ts
8/24/20 FND'N PERMIT
9/8/20 FND'N REVISION
10/30/20
Sub-2 2006-006

Scale:
Sheet:

Roof
Plans
A2.3

VANEY / SHINDE
New Residence
4207 West Mercer Way
Mercer Island, WA 98040

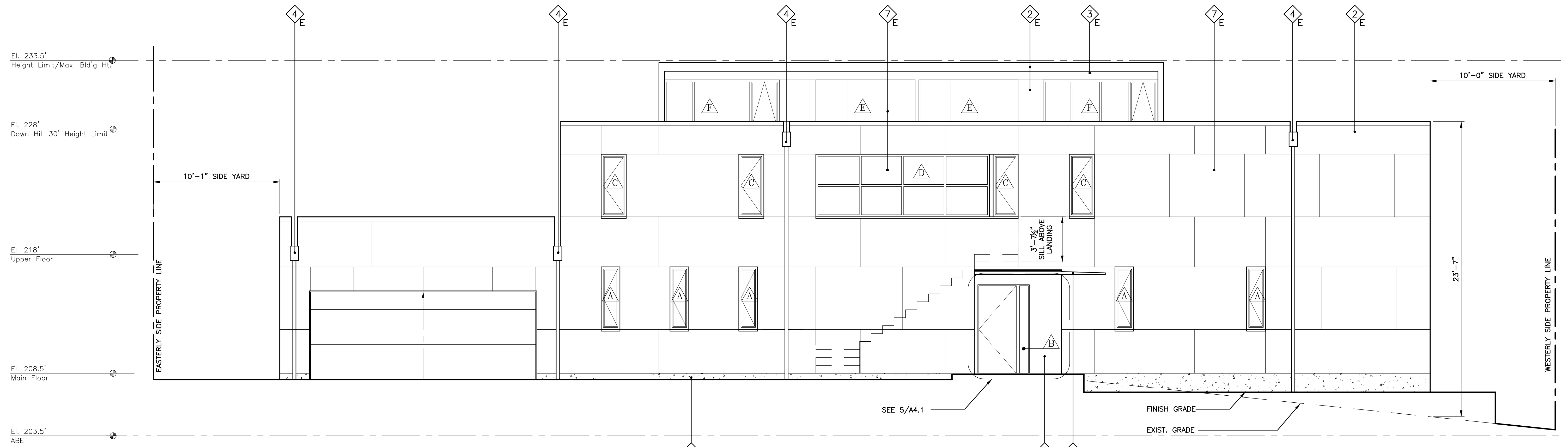

1 North Elevation
scale: 1/4"=1'-0"

NOTE:
1. SEE A3.2 FOR EXTERIOR MATERIALS LEGEND
2. SEE A9.1 FOR WINDOW SCHEDULE

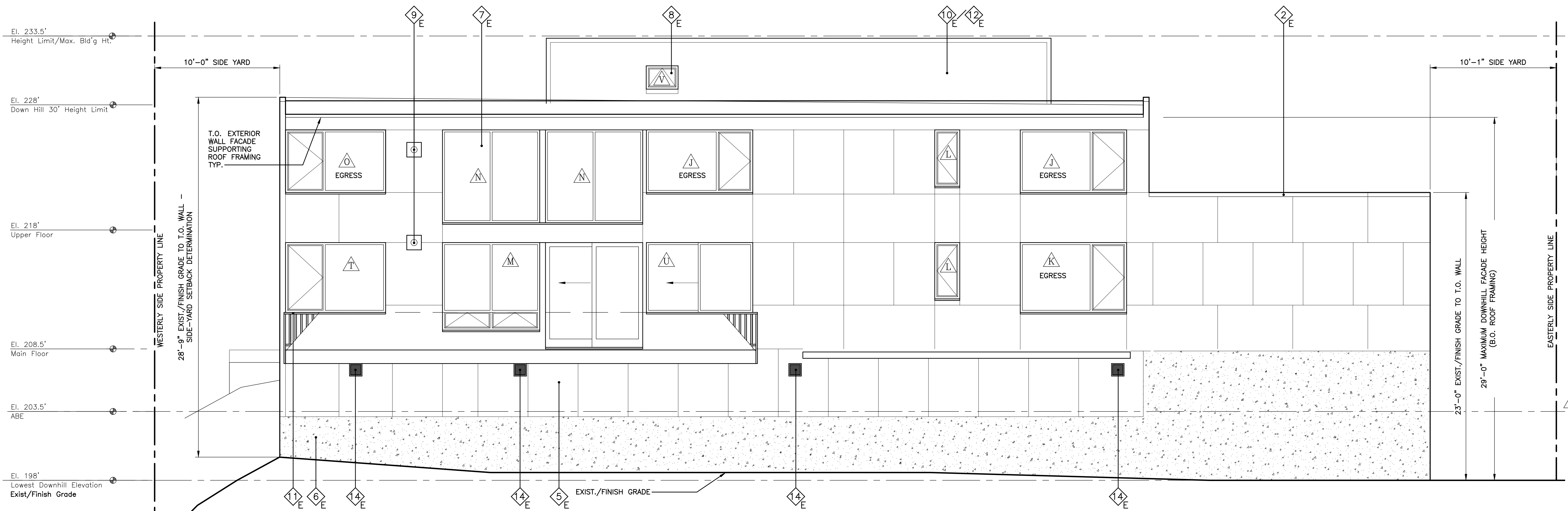

2 South Elevation
scale: 1/4"=1'-0"

Date:
5/27/20 Permit Sub
7/15/20 Early Comnt's
8/24/20 FND'N PERMIT
9/8/20 FND'N REVISION
10/30/20
Sub-2 2006-006

Scale:
Sheet:
Elevations

A3.1

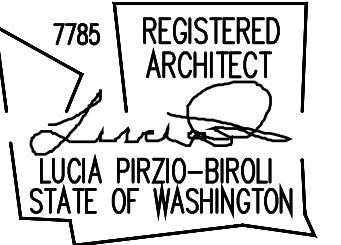
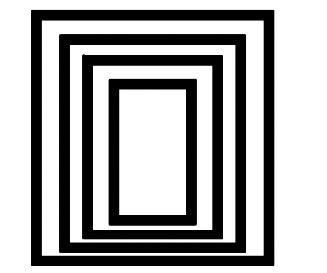

EXTERIOR MATERIAL LEGEND:

- 1_E 12" METAL WALL CLAD-TAYLOR "SMOOTH WALL" FLAT PAN - COLOR TBD
- 2_E METAL PANEL/COPING/FLASHING - COLOR TO MATCH METAL WALL CLAD
- 3_E HORIZ./VERT. 4" CEDAR SIDING - STAIN COLOR TBD
- 4_E METAL GUTTER/OVERFLOW SCUPPER/DOWNSPOUT METAL - COLOR TO MATCH METAL WALL CLAD
- 5_E HARDI-PANEL RAINSCREEN - SMOOTH FINISH - NON EXP. FASTENERS - COLOR TBD
- 6_E CONCRETE STEM WALLS
- 7_E FIBERGLASS WINDOWS
- 8_E METAL CLAD VELUX SKYLIGHT
- 9_E GAS FIREPLACE DIRECT VENT HORIZ. TERMINATION CAP
- 10_E TPO ROOFING - COLOR GRAY EXPOSED
- 11_E WOOD HANDRAIL
- 12_E FUTURE PHOTOVOLTAIC PANELS - INSTALL ROOF CLIPS
- 13_E 16"x24" ACCESS OPENING W/ 1 SF. CRAWL SPACE VENT
- 14_E 1 SF. CRAWL SPACE VENT

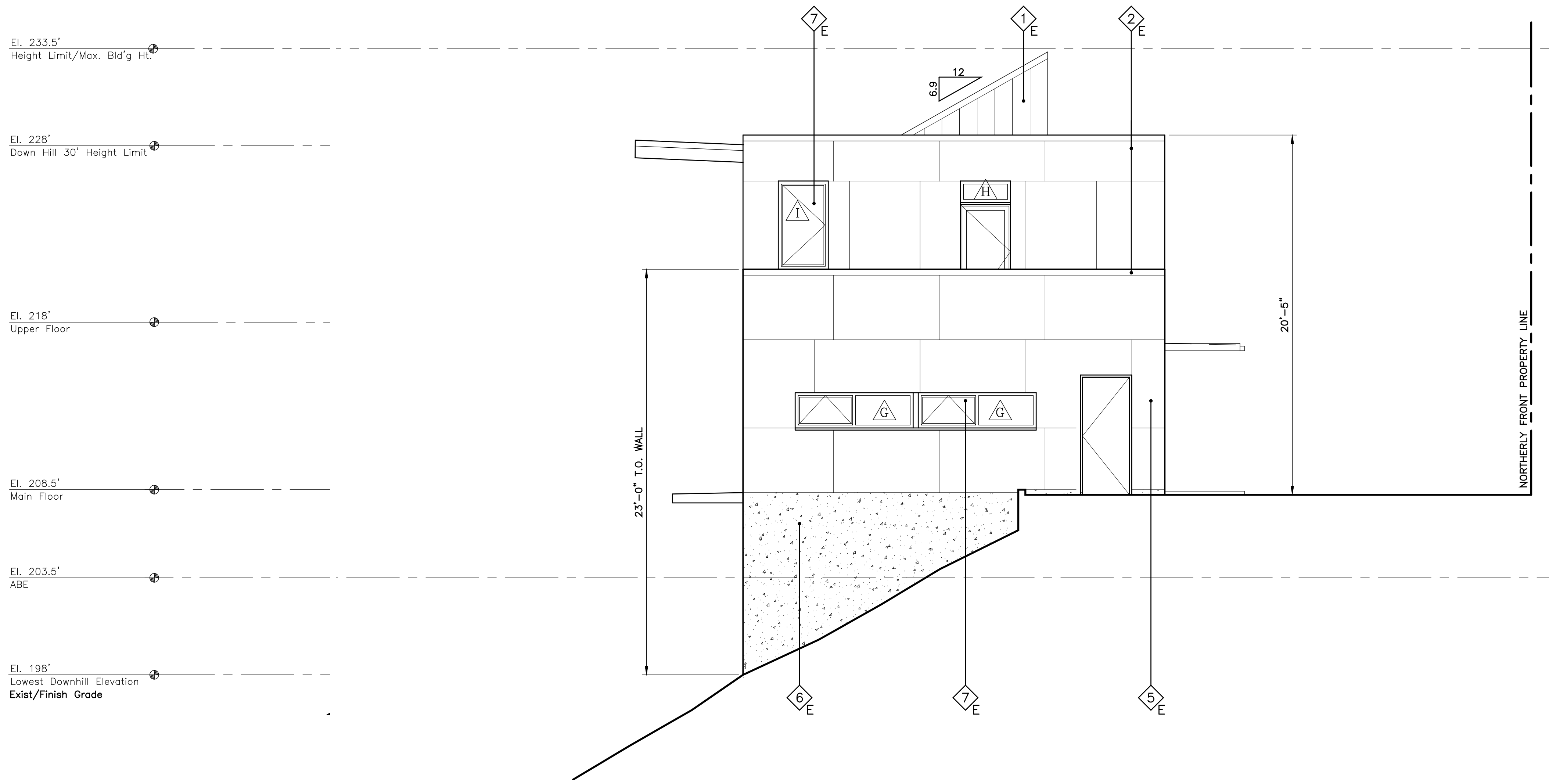

1 **East Elevation**
Scale: 1/4"=1'-0"

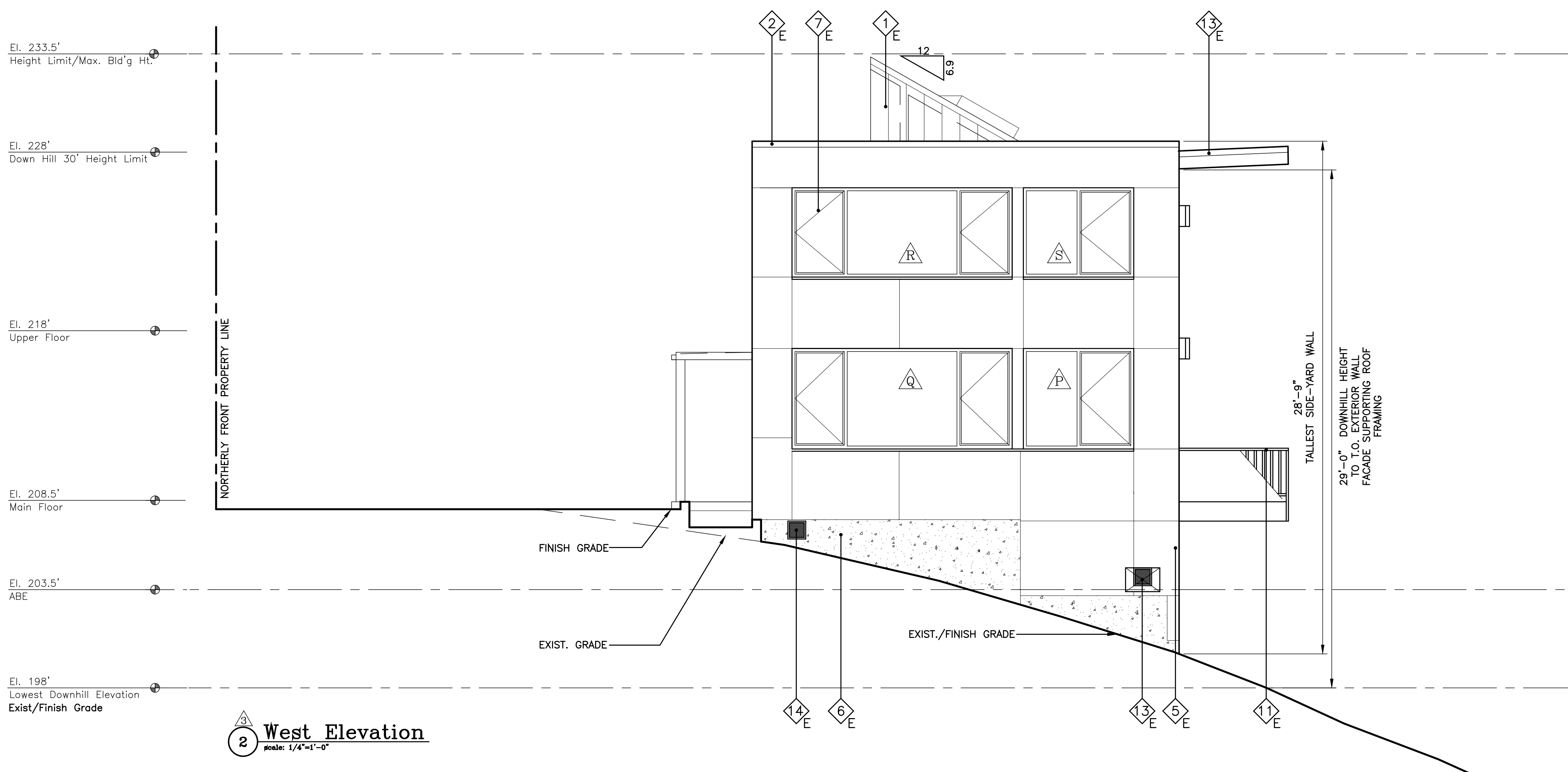

2 **West Elevation**
Scale: 1/4"=1'-0"

VANEY / SHINDE
New Residence
4207 West Mercer Way
Mercer Island, WA 98040

Date:
5/27/20 Permit Sub
7/15/20 Early Comnts
8/24/20 FND'N PERMIT
9/8/20 FND'N REVISION
10/30/20
Sub-2 2006-006

Scale:

Sheet:

Elevations

A3.2

EXTERIOR MATERIAL LEGEND:

- 1_E 12" METAL WALL CLAD-TAYLOR "SMOOTH WALL" FLAT PAN - COLOR TBD
- 2_E METAL PANEL/COPING/FLASHING - COLOR TO MATCH METAL WALL CLAD
- 3_E HORIZ./VERT. 4" CEDAR SIDING - STAIN COLOR TBD
- 4_E METAL GUTTER/OVERFLOW SCUPPER/DOWNSPOUT METAL - COLOR TO MATCH METAL WALL CLAD
- 5_E HARDI-PANEL RAINSCREEN - SMOOTH FINISH - NON EXP. FASTENERS - COLOR TBD
- 6_E CONCRETE STEM WALLS
- 7_E FIBERGLASS WINDOWS
- 8_E METAL CLAD VELUX SKYLIGHT
- 9_E GAS FIREPLACE DIRECT VENT HORIZ. TERMINATION CAP
- 10_E TPO ROOFING - COLOR GRAY EXPOSED
- 11_E WOOD HANDRAIL
- 12_E FUTURE PHOTOVOLTAIC PANELS - INSTALL ROOF CLIPS
- 13_E 16"x24" ACCESS OPENING W/ 1 SF. CRAWL SPACE VENT
- 14_E 1 SF. CRAWL SPACE VENT

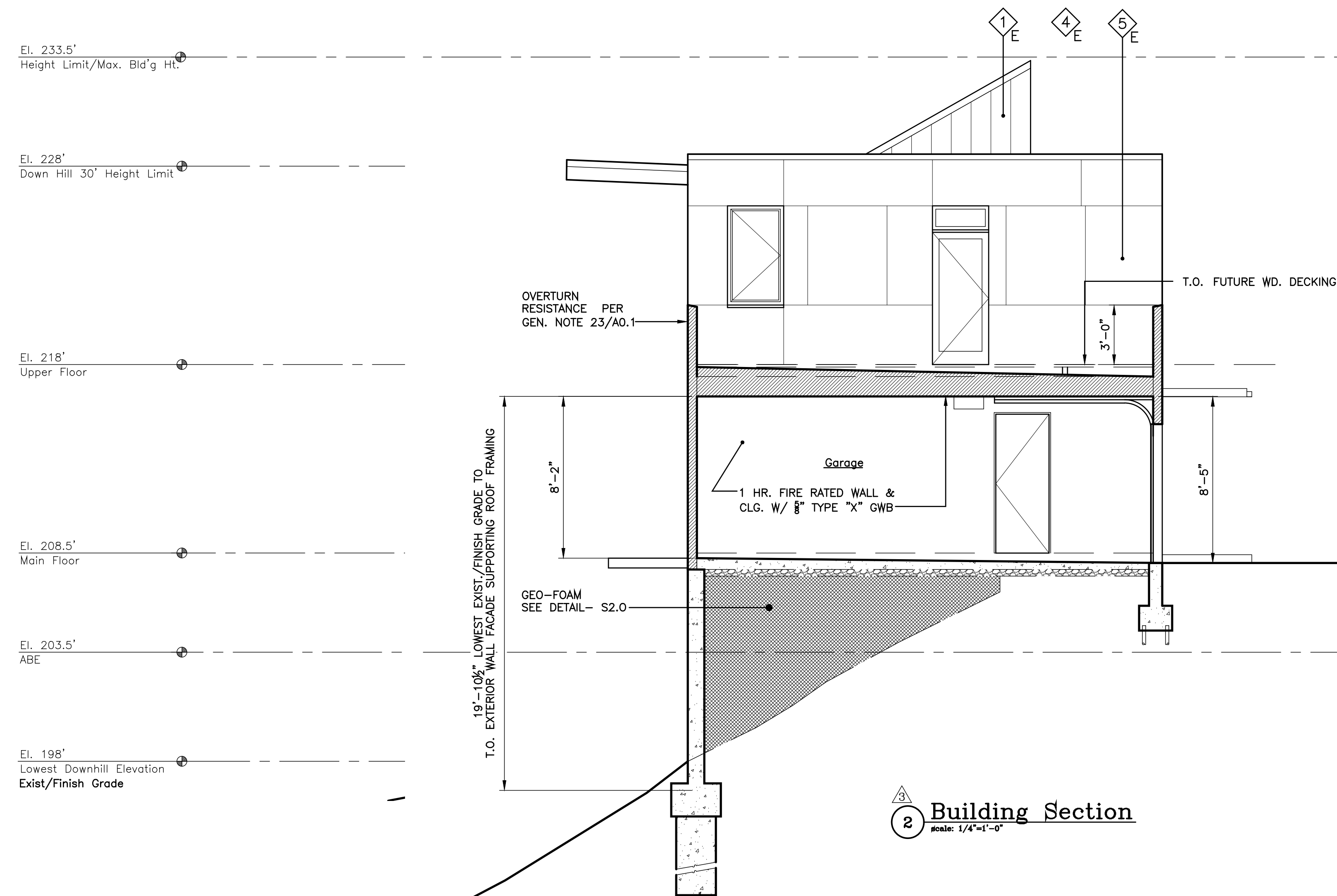
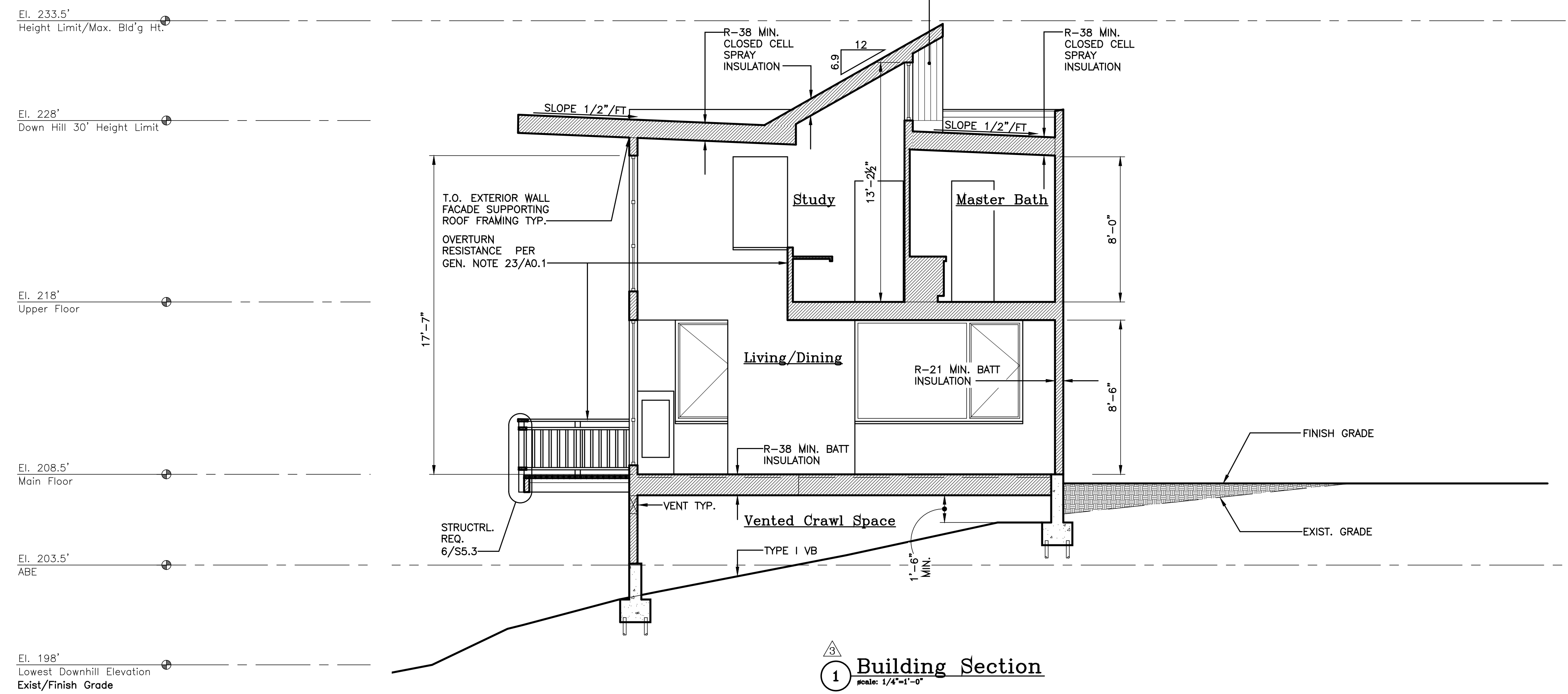

VANEY / SHINDE
New Residence
4207 West Mercer Way
Mercer Island, WA 98040

Date:
5/27/20 Permit Sub
7/15/20 Early Com'n ts
8/24/20 FND'N PERMIT
9/8/20 FND'N REVISION
10/30/20
Sub-2 2006-006

Scale:
Sheet:
Building Sections
A4.1

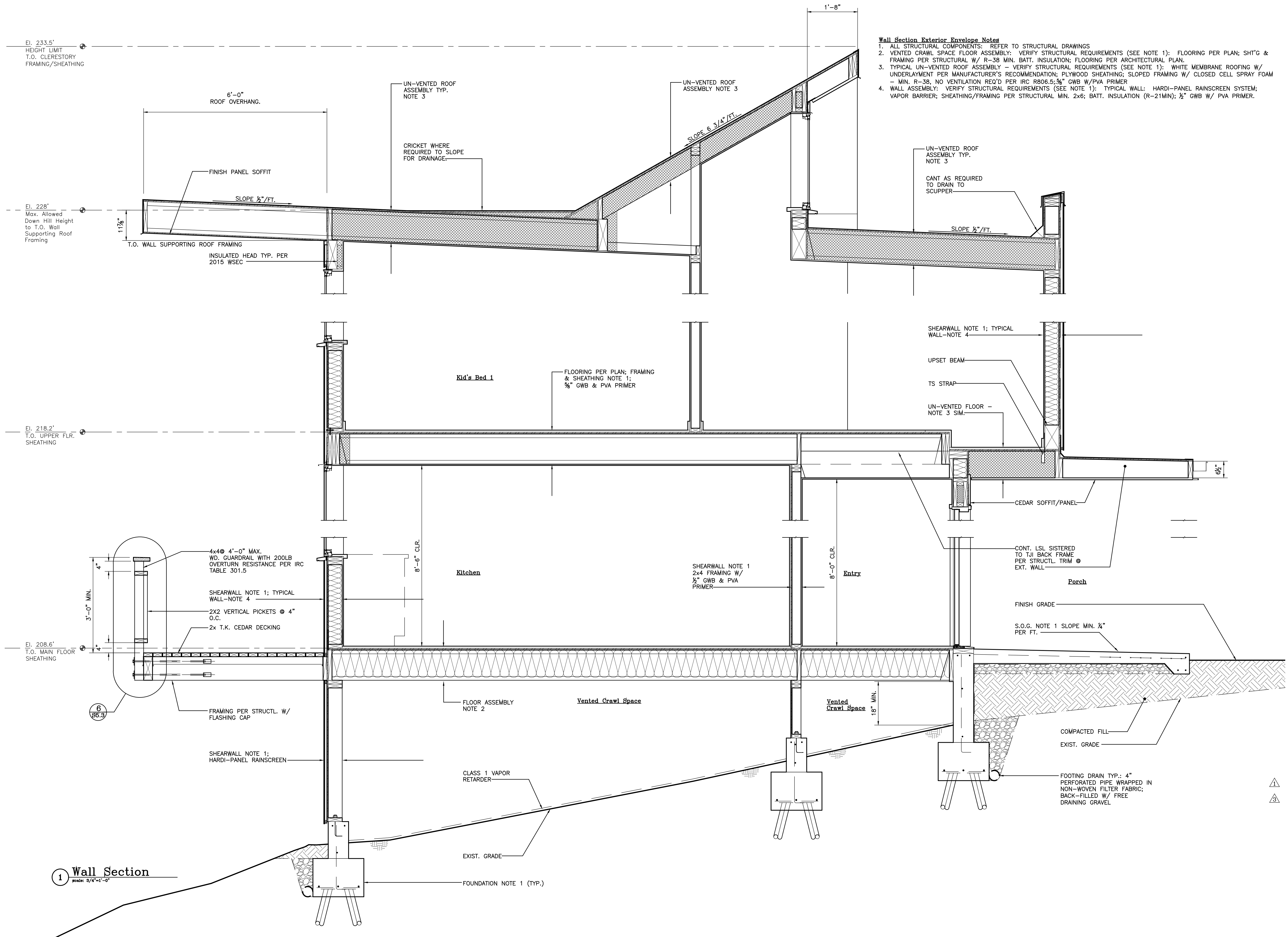
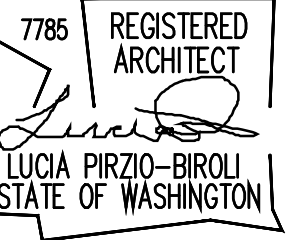
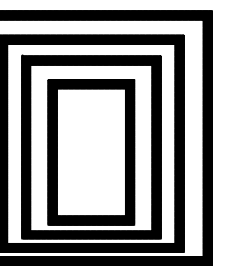

VANEY / SHINDE
New Residence
4207 West Mercer Way
Mercer Island, WA 98040

1 Wall Section
Scale: 3/4"=1'-0"

Date:
5/27/20 Permit Sub
7/15/20 Early Com'ts
8/24/20 FND'N PERMIT
9/8/20 FND'N REVISION
10/30/20
Sub-2 2006-006

Scale:
Sheet:
Wall Sections
A5.1

Window Schedule

TAG	UNIT WINDOW SIZE		UNIT AREA	QTY.	TOTAL	MAX U-VALUE	UA VALUE	SILL HEIGHT (AFF)	TYPE OPERATION	FRAME / FINISH	GLASS	MANUF.	MODEL	NOTES
	Note 1										square ft.			
	width	height												
A	1'-6"	x 5'-0"	7.5 SQ. FT.	5	37.5 SQ. FT.	0.28	10.5 SQ. FT.	3'-6"	CASE	FIBERGLASS/FACTORY FINISH	DBL/LO-E/ARGON	MARVIN	ESSENTIAL	
B	0'-8"	x 7'-0"	4.7 SQ. FT.	1	4.7 SQ. FT.	0.28	1.3 SQ. FT.	0'-0 1/2"	FIX	WOOD/PAINT	DBL/LO-E/ARGON/TG	N/A	N/A	FIELD SET SIDE LIGHT COORD. W/ ENTRY DOOR
C	2'-0"	x 5'-0"	10.0 SQ. FT.	4	40.0 SQ. FT.	0.28	11.2 SQ. FT.	3'-0"	CASE	FIBERGLASS/FACTORY FINISH	DBL/LO-E/ARGON	MARVIN	ESSENTIAL	
D	13'-10"	x 5'-0"	69.2 SQ. FT.	1	69.2 SQ. FT.	0.28	19.4 SQ. FT.	3'-0"	FIX	FIBERGLASS/FACTORY FINISH	DBL/LO-E/ARGON	MARVIN	ESSENTIAL	COORD. WIDTH AS REQ'D W/ ARCH.
E	7'-7"	x 3'-2 1/4"	24.2 SQ. FT.	2	48.3 SQ. FT.	0.28	13.5 SQ. FT.	10'-0"	FIX	FIBERGLASS/FACTORY FINISH	DBL/LO-E/ARGON	MARVIN	ESSENTIAL	COORD. MULLIONS W/ ADJ. UNITS
F	9'-2"	x 3'-2 1/4"	29.2 SQ. FT.	2	58.4 SQ. FT.	0.28	16.4 SQ. FT.	10'-0"	AWN/FIX	FIBERGLASS/FACTORY FINISH	DBL/LO-E/ARGON	MARVIN	ESSENTIAL	COORD. MULLIONS W/ ADJ. UNITS/ MOTORIZED OPERATION
G	6'-8"	x 2'-0"	13.3 SQ. FT.	2	26.7 SQ. FT.	0.28	7.5 SQ. FT.	3'-6"	AWN/FIX	FIBERGLASS/FACTORY FINISH	DBL/LO-E/ARGON	MARVIN	ESSENTIAL	
H	2'-10"	x 1'-2"	3.3 SQ. FT.	1	3.3 SQ. FT.	0.28	0.9 SQ. FT.	7' VIF	TRANSOM	FIBERGLASS/FACTORY FINISH	DBL/LO-E/ARGON	MARVIN	ESSENTIAL	COORD. W/ DOOR 4
I	2'-10"	x 5'-0"	14.2 SQ. FT.	1	14.2 SQ. FT.	0.28	4.0 SQ. FT.	3'-0"	CASE	FIBERGLASS/FACTORY FINISH	DBL/LO-E/ARGON	MARVIN	ESSENTIAL	EGRESS
J	8'-6"	x 5'-0"	42.5 SQ. FT.	2	85.0 SQ. FT.	0.28	23.8 SQ. FT.	3'-0"	CASE/FIX	FIBERGLASS/FACTORY FINISH	DBL/LO-E/ARGON	MARVIN	ESSENTIAL	MIRROR UNITS/EGRESS @ "KID'S BED 1"
K	8'-6"	x 5'-7"	47.5 SQ. FT.	1	47.5 SQ. FT.	0.28	13.3 SQ. FT.	3'-0"	CASE/FIX	FIBERGLASS/FACTORY FINISH	DBL/LO-E/ARGON	MARVIN	ESSENTIAL	ALIGN W/ "J" ABOVE / EGRESS
L	2'-0"	x 4'-6"	9.0 SQ. FT.	2	18.0 SQ. FT.	0.28	5.0 SQ. FT.	4'-0"	CASE	FIBERGLASS/FACTORY FINISH	DBL/LO-E/ARGON/TG	MARVIN	ESSENTIAL	TEMPERED GLASS @ SHOWER ONLY
M	7'-9"	x 7'-0"	54.4 SQ. FT.	1	54.4 SQ. FT.	0.28	15.2 SQ. FT.	1'-6"	AWN/FIX	FIBERGLASS/FACTORY FINISH	DBL/LO-E/ARGON/TG	MARVIN	ESSENTIAL	ALIGN W/ "N" BELOW
N	7'-9"	x 7'-5"	57.5 SQ. FT.	2	115.0 SQ. FT.	0.28	32.2 SQ. FT.	10'-1" VIF	FIX	FIBERGLASS/FACTORY FINISH	DBL/LO-E/ARGON	MARVIN	ESSENTIAL	ALIGN W/ "M" BELOW
O	8'-0"	x 5'-0"	40.0 SQ. FT.	1	40.0 SQ. FT.	0.28	11.2 SQ. FT.	7"	CASE/FIX	FIBERGLASS/FACTORY FINISH	DBL/LO-E/ARGON/TG	MARVIN	ESSENTIAL	ALIGN W/ "T" BELOW - EGRESS
P	6'-2"	x 7'-0"	43.3 SQ. FT.	1	43.3 SQ. FT.	0.28	12.1 SQ. FT.	12'-6" VIF	CASE/FIX/AWN	FIBERGLASS/FACTORY FINISH	DBL/LO-E/ARGON	MARVIN	ESSENTIAL	ALIGN W/ "S" ABOVE
Q	12'-4"	x 5'-6"	67.8 SQ. FT.	1	67.8 SQ. FT.	0.28	19.0 SQ. FT.	0'-1 1/2"	CASE/FIX/AWN	FIBERGLASS/FACTORY FINISH	DBL/LO-E/ARGON/TG	MARVIN	ESSENTIAL	ALIGN W/ "R" ABOVE
R	12'-4"	x 5'-0"	61.7 SQ. FT.	1	61.7 SQ. FT.	0.28	17.3 SQ. FT.	3'-0"	FIX/CASE	FIBERGLASS/FACTORY FINISH	DBL/LO-E/ARGON	MARVIN	ESSENTIAL	ALIGN W/ "Q" BELOW
S	6'-2"	x 5'-0"	30.8 SQ. FT.	1	30.8 SQ. FT.	0.28	8.6 SQ. FT.	3'-0"	FIX/CASE	FIBERGLASS/FACTORY FINISH	DBL/LO-E/ARGON	MARVIN	ESSENTIAL	ALIGN WITH "P" BELOW
T	8'-0"	x 5'-6"	44.0 SQ. FT.	1	44.0 SQ. FT.	0.28	12.3 SQ. FT.	3'-0"	FIX/CASE	FIBERGLASS/FACTORY FINISH	DBL/LO-E/ARGON	MARVIN	ESSENTIAL	ALIGN WITH "O" ABOVE
U	8'-6"	x 5'-6"	46.8 SQ. FT.	1	46.8 SQ. FT.	0.28	13.1 SQ. FT.	3'-0"	SLIDE/FIX	FIBERGLASS/FACTORY FINISH	DBL/LO-E/ARGON	MARVIN	ESSENTIAL	
V	2'-6 1/2"	x 2'-8 1/4"	6.8 SQ. FT.	1	6.8 SQ. FT.	0.50	3.4 SQ. FT.	ROOF	SOLAR OPER	ALUM/WD/PT	DBL/LO-E/ARGON/TG	VELUX	VSS M02	REMOTE CONTROL/SCREEN/SHADE / VIF R.O.

Exterior Door to Conditioned Space

TAG	PANEL SIZE		UNIT AREA	QTY.	TOTAL	MAX U-VALUE	UA VALUE	Thickness	TYPE	FRAME/FINISH	GLASS	MANUF.	MODEL	NOTES
	width	height												
1	3'-0"	x 7'-0"	21.0 SQ. FT.	1	21.0 SQ. FT.	.24	5.0 SQ. FT.	0'-1 3/4"	SC/SLAB	WD/STAIN	NA	TBD		DEAD BOLT/COORD W/ WINDOW "B"
2	4'-0"	x 7'-0"	28.0 SQ. FT.	2	56.0 SQ. FT.	.24	13.4 SQ. FT.	0'-1 3/4"	BI-PASS/STORE	FIBERGLASS/FACTORY FINISH	DBL/LO-E/ARGON	MARVIN	ULTIMATE LIFT & SLIDE	MULTI-POINT LOCK SYSTEM/FLUSH PULLS
3	2'-8"	x 6'-8"	17.8 SQ. FT.	1	17.8 SQ. FT.	.27	4.8 SQ. FT.	0'-1 3/4"	SC/20 MIN/FLUSH	STEEL/PAINTED	NA	TBD		DEADBOLT/SELF-CLOSING HARDWARE
4	2'-10"	x 6'-8"	18.9 SQ. FT.	1	18.9 SQ. FT.	.27	5.1 SQ. FT.	0'-1 3/4"	STORE	FIBERGLASS & WOOD/FACTORY FINISH	DBL/LO-E/ARGON/TG	MARVIN	TBD	DEADBOLT/COORD. W/ WINDOW "H"
5														NOT USED
AREAS OF WINDOWS & DOORS IMPACTING UA:			WINDOW/EXT. DOOR AREA		1077.0 SQ. FT.	TOTAL UA	299.6 SQ. FT.							

WINDOW & EXTERIOR DOOR NOTES:

1. CONTRACTOR SHALL MEASURE ACTUAL FRAMED OPENINGS PRIOR TO ORDERING UNITS. ROUGH OPENING PER MANUFACTURER'S REQUIREMENTS.
2. (3) MINIMUM HEAVY DUTY CONCEALED HINGES MIN. AT ALL EXTERIOR DOORS
3. WINDOW MANUFACTURER: MARVIN EXCEPT AS NOTED OTHERWISE
4. WINDOW MANUFACTURER TO VERIFY OPERATION AND WIDTH OPENING - COORDINATE WITH ARCHITECT WHERE DIFFERS FROM DRAWINGS
5. TEMPERED GLASS: WITHIN TWO FEET OF ALL EXTERIOR DOORS, AND WITHIN 18" OF FLOOR AND OTHER HAZARDOUS LOCATIONS AS IDENTIFIED IN IRC R308.4
6. GLASS - LO-E3/LOW ERS / ARGON FILLED AT ALL MARVIN WINDOWS AND EXTERIOR DOORS
7. EGRESS WINDOWS AT SLEEPING ROOMS SHALL MEET IRC R310
8. EBC 1a: EFFICIENT BUILDING ENVELOPE ALL NEW EXTERIOR WINDOWS AND DOORS SHALL MEET MINIMUM U-28 MINIMUM PRESCRIPTIVE COMPLIANCE.

Studio Ectypos
ARCHITECTURE

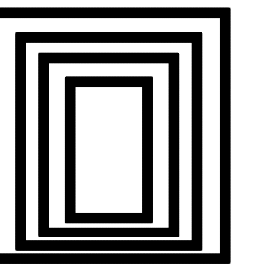

4212 W. Mercer Way
Mercer Island, WA 98040
t. (206)232-9147
www.studioectypos.com

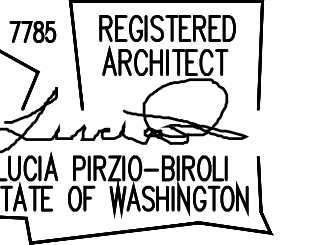

ABBREVIATIONS

AWN	AWNING
CASE	CASEMENT
CLR	CLEAR
DBL	DOUBLE GLAZING
FIX	FIXED
HC	HOLLOW CORE
LAM	LAMINATED
LO-E	LOW-EMISSIVITY
MIN	MINUTE
OBS	OBSOLETE
R.O.	ROUGH OPENING
SC	SOLID CORE
SLD	SLIDING
SL	SKYLIGHT
STORE	STOREFRONT
TBD	TO BE DETERMINED
TG	TEMPERED GLASS
TRPL	TRIPLE
UA	U-VALUE AREA
WD	WOOD

VANEY / SHINDE

New Residence
4207 West Mercer Way
Mercer Island, WA 98040

Date:
5/27/20 Permit Sub
7/15/20 Early Comnts
8/24/20 FND'N PERMIT
9/8/20 FND'N REVISION
10/30/20
Sub-2 2006-006

Scale:
Sheet:

Window/Door
Schedules
A9.1

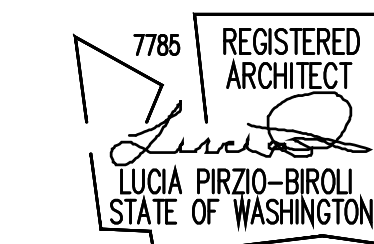
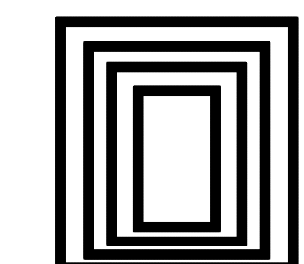

INTERIOR DOOR NOTES:
1. (3) HINGES MINIMUM
2. HANDLE LEVER UNO
3. UNDERCUT DOORS TO INHABITABLE SPACES AS NECESSARY TO MEET WHOLE HOUSE VENTILATION REQUIREMENTS

Interior Door Schedule & Exterior Doors at Unheated Spaces												
TAG	PANEL SIZE			PANEL QTY.	UNIT AREA square ft.	Thickness	TYPE	MATERIAL/ FINISH	GLASS	HARDWARE	MANUF.	NOTES
	width	x	height									
6	2'-6"	x	6'-8"	1	16.7 SQ. FT.	0'-1 3/8"	STORE	BIRCH/CLR	OBS/TG	DBL. ACT./PUSH PLATE	TBD.	
7	3'-0"	x	6'-8"	1	20.0 SQ. FT.	0'-1 3/8"	STORE	BIRCH/CLR	OBS/TG	LEVER	TBD.	
8	2'-4"	x	6'-8"	1	15.6 SQ. FT.	0'-1 3/8"	SC/SLAB	BIRCH/CLR	N/A	LEVER/PRIVACY	TBD	
9	2'-8"	x	6'-8"	1	17.8 SQ. FT.	0'-1 3/8"	STORE	BIRCH/CLR	OBS/TG	LEVER	TBD	
10	3'-0"	x	6'-8"	1	20.0 SQ. FT.	0'-1 3/8"	SC/SLAB	BIRCH/CLR	N/A	LEVER/PRIVACY	TBD	
11	3'-0"	x	6'-8"	1	20.0 SQ. FT.	0'-1 3/8"	SC/SLAB	BIRCH/CLR	N/A	LEVER/PRIVACY	TBD	
12	2'-4"	x	6'-8"	2	15.6 SQ. FT.	0'-1 3/8"	HC/SLAB	BIRCH/CLR	N/A	RC/PULL	TBD	
13	2'-4"	x	6'-8"	1	15.6 SQ. FT.	0'-1 3/8"	HC/SLAB	BIRCH/CLR	N/A	RC/PULL	TBD	
14	1'-6"	x	6'-8"	2	10.0 SQ. FT.	0'-1 3/8"	HC/SLAB	BIRCH/CLR	N/A	RC/PULL	TBD	
15	2'-6"	x	6'-8"	2	16.7 SQ. FT.	0'-1 3/8"	HC/SLAB	BIRCH/CLR	N/A	RC/PULL	TBD	
16	3'-6"	x	6'-8"	1	23.3 SQ. FT.	0'-1 3/8"	SC/SLAB	BIRCH/CLR	N/A	LEVER/PRIVACY	TBD	VERIFY W/ OWNER VS. (1) 3'-0" WIDE
17	2'-4"	x	6'-8"	1	15.6 SQ. FT.	0'-1 3/8"	STORE/PKT	BIRCH/CLR	OBS/TG	PULL	TBD	
18	2'-8"	x	6'-8"	1	17.8 SQ. FT.	0'-1 3/8"	SC/SLAB	BIRCH/CLR	N/A	LEVER/PRIVACY	TBD	
19	2'-8"	x	6'-8"	1	17.8 SQ. FT.	0'-1 3/8"	SC/SLAB	BIRCH/CLR	N/A	LEVER/PRIVACY	TBD	
20	2'-4"	x	6'-8"	1	15.6 SQ. FT.	0'-1 3/8"	SC/SLAB	BIRCH/CLR	N/A	LEVER/PRIVACY	TBD	
21	2'-4"	x	6'-8"	1	15.6 SQ. FT.	0'-1 3/8"	SC/PKT	BIRCH/CLR	OBS/TG	PULL	TBD	
22	3'-0"	x	6'-8"	2	20.0 SQ. FT.	0'-1 3/8"	HC/SLAB	BIRCH/CLR	N/A	RC/PULL	TBD	
23	3'-0"	x	6'-8"	2	20.0 SQ. FT.	0'-1 3/8"	HC/SLAB	BIRCH/CLR	N/A	RC/PULL	TBD	
24	3'-0"	x	6'-8"	1	20.0 SQ. FT.	0'-1 3/8"	STORE/PKT	BIRCH/CLR	OBS/TG	PULL	TBD	FIT TO WIDTH OF HALL
25	2'-8"	x	6'-8"	1	17.8 SQ. FT.	0'-1 3/4"	SC/SLAB	FG/PAINT	N/A	DEAD BOLT/ LEVER	MARVIN	
26	18'-0"	x	7'-0"	1	126.0 SQ. FT.			STL/PAINT	N/A	OVERHEAD TRACK/MOTOR	TBD	

ABBREVIATIONS
 AWN AWNING
 CASE CASEMENT
 CLR CLEAR
 DBL DOUBLE GLAZING
 FIX FIXED
 HC HOLLOW CORE
 LAM LAMINATED
 LO-E LOW-EMISSIVITY
 MIN MINUTE
 OBS OBSOURE
 R.O. ROUGH OPENING
 SC SOLID CORE
 SLD SLIDING
 SL SKYLIGHT
 STORE STOREFRONT
 TBD TO BE DETERMINED
 TG TEMPERED GLASS
 TRPL TRIPLE
 UA U-VALUE AREA
 WD WOOD

VANEY / SHINDE
 New Residence
 4207 West Mercer Way
 Mercer Island, WA 98040

Date:
 5/27/20 Permit Sub
 7/15/20 Early Comnts
 8/24/20 FND'N PERMIT
 9/8/20 FND'N REVISION
 10/30/20
 Sub-2 2006-006

Scale:

Sheet:

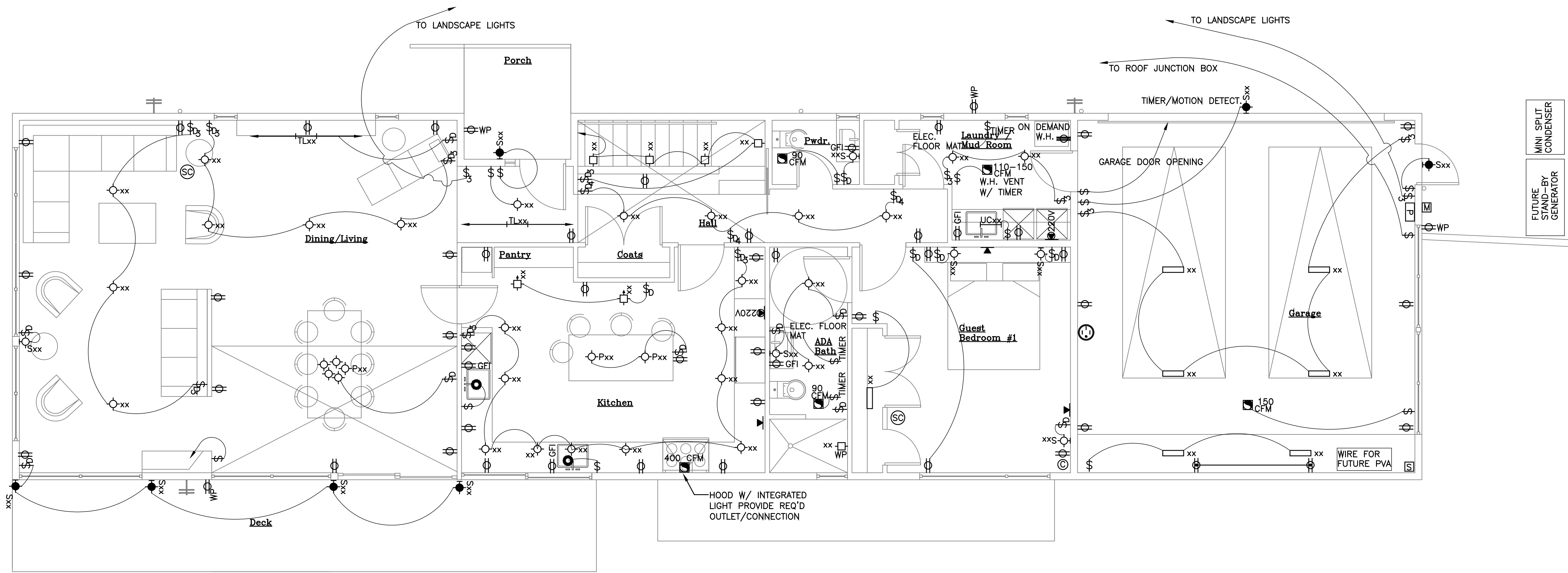

1 Main Floor Plan
Scale: 1/4"=1'-0"

- Electrical Plan Notes:**
1. WHOLE HOUSE VENTILATION SHALL MEET IRC M1507.4 WHOLE HOUSE VENTILATION USING INTERMITTENT EXHAUST FANS AND FRESH AIR INLETS. A MINIMUM WHOLE HOUSE VENTILATION RATE OF 150CFM FOR EACH OF TWO DESIGNATED FANS. ALL HABITABLE ROOMS HAVE OPERABLE WINDOWS THAT MEETS AND EXCEEDS REQUIREMENTS OF IRC 1507.3.3.
 2. A MINIMUM OF 75% OF NEW PERMANENTLY INSTALLED LAMPS IN NEW LIGHTING FIXTURES WILL BE HIGH EFFICACY (WAC 51-11R-R404.1)
 3. EXHAUST HOOD SYSTEMS GREATER THAN A CFM OF 400 SHALL MEET THE REQUIREMENTS OF IRC M1503.4 FOR MAKE UP AIR
 4. PROVIDE KITCHEN AND LAUNDRY OUTLETS ACCORDING TO APPLIANCES MANUFACTURER SPECIFICATIONS
 5. CONTRACTOR TO COORDINATE (2) WALK-THROUGHS PRIOR TO LOCATING FIXTURES, OUTLETS AND SWITCHES AND PRIOR TO FINALIZATION
 6. EEC 2a: Air Leakage Control and Efficient Ventilation SEE SHEET AO.1 FOR DETAILED DESCRIPTION.

Power and Lighting Legend

	Recessed Ceiling Mounted Exhaust Fan
	Recessed Ceiling Mounted Smoke Detector/Carbon Monoxide
	Cable Connection
	Floor Mounted Cable Connection
	Dedicated Data Outlet (CatVI)
	Switch
	Switch, Multi-way
	Switch, Dimmer
	Switch, Dimmer/Multi-way
	Switch, Door Activated
	Duplex Outlet
	Ground Fault Circuit Interrupter
	Exterior Duplex Outlet
	Four-plex Outlet
	Floor Mounted Duplex Outlet
	Strip Outlets
	220 V Outlet
	Breaker Panel
	Meter
	Security Panel
	Recessed Ceiling Mounted LED Downlight
	Recessed Ceiling Mounted LED Wallwasher
	Surface Ceiling Mounted LED Downlight
	Surface Mounted Wall LED Sconce
	Surface Mounted Track LED Lighting
	Surface Mounted Undercabinet Strip LED Lighting
	Ribbon LED linear light
	Pendant Fixture
	Cluster Pendant Fixture
	Surface Mounted Downlight
	Surface Mounted LED Batten Fixture
	Recessed Mounted Wall LED Washer
	Recessed Wall LED Light
	Exterior Recessed Ceiling Mounted LED Downlight
	Exterior Ground LED Light
	Exterior Surface Mounted Wall LED Sconce
	Exterior Recessed Wall LED Step Light
	Exterior Direct Burial Uplight
	Pool Light
	Waste Disposal
	Level 2 240V EV Charger

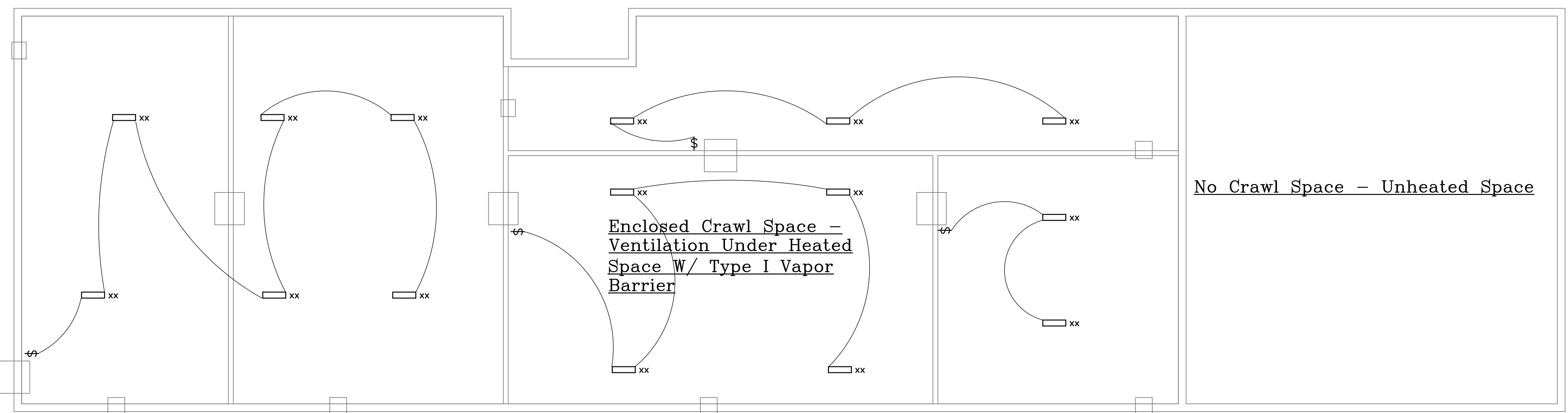

2 Crawl Space Plan
Scale: 1/4"=1'-0"

Date:
5/27/20 Permit Sub
7/15/20 Early Comm'ts
8/24/20 FND'N PERMIT
9/8/20 FND'N REVISION
10/30/20
Sub-2 2006-006

Scale:
Sheet:

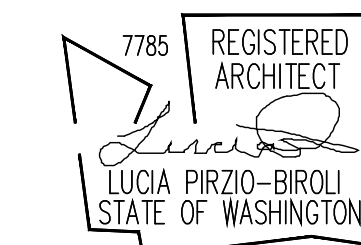
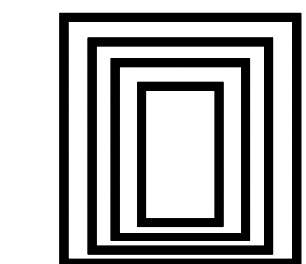

Power and Lighting Legend

- Recessed Ceiling Mounted Exhaust Fan
- Recessed Ceiling Mounted Smoke Detector/Carbon Monoxide
- Cable Connection
- Floor Mounted Cable Connection
- Dedicated Data Outlet (CatV)
- Switch
- Switch, Multi-way
- Switch, Dimmer
- Switch, Dimmer/Multi-way
- Switch, Door Activated
- Duplex Outlet
- Ground Fault Circuit Interrupter
- Exterior Duplex Outlet
- Four-plex Outlet
- Floor Mounted Duplex Outlet
- Strip Outlets
- 220 V Outlet
- Breaker Panel
- Meter
- Security Panel
- Recessed Ceiling Mounted LED Downlight
- Recessed Ceiling Mounted LED Wallwasher
- Surface Ceiling Mounted LED Downlight
- Surface Mounted Wall LED Sconce
- Surface Mounted Track LED Lighting
- Surface Mounted Undercabinet Strip LED Lighting
- Ribbon LED linear light
- Pendant Fixture
- Cluster Pendant Fixture
- Surface Mounted Downlight
- Surface Mounted LED Batten Fixture
- Recessed Mounted Wall LED Washer
- Recessed Wall LED Light
- Exterior Recessed Ceiling Mounted LED Downlight
- Exterior Ground LED Light
- Exterior Surface Mounted Wall LED Sconce
- Exterior Recessed Wall LED Step Light
- Exterior Direct Burial Uplight
- Pool Light
- Waste Disposal
- Level 2 240V EV Charger

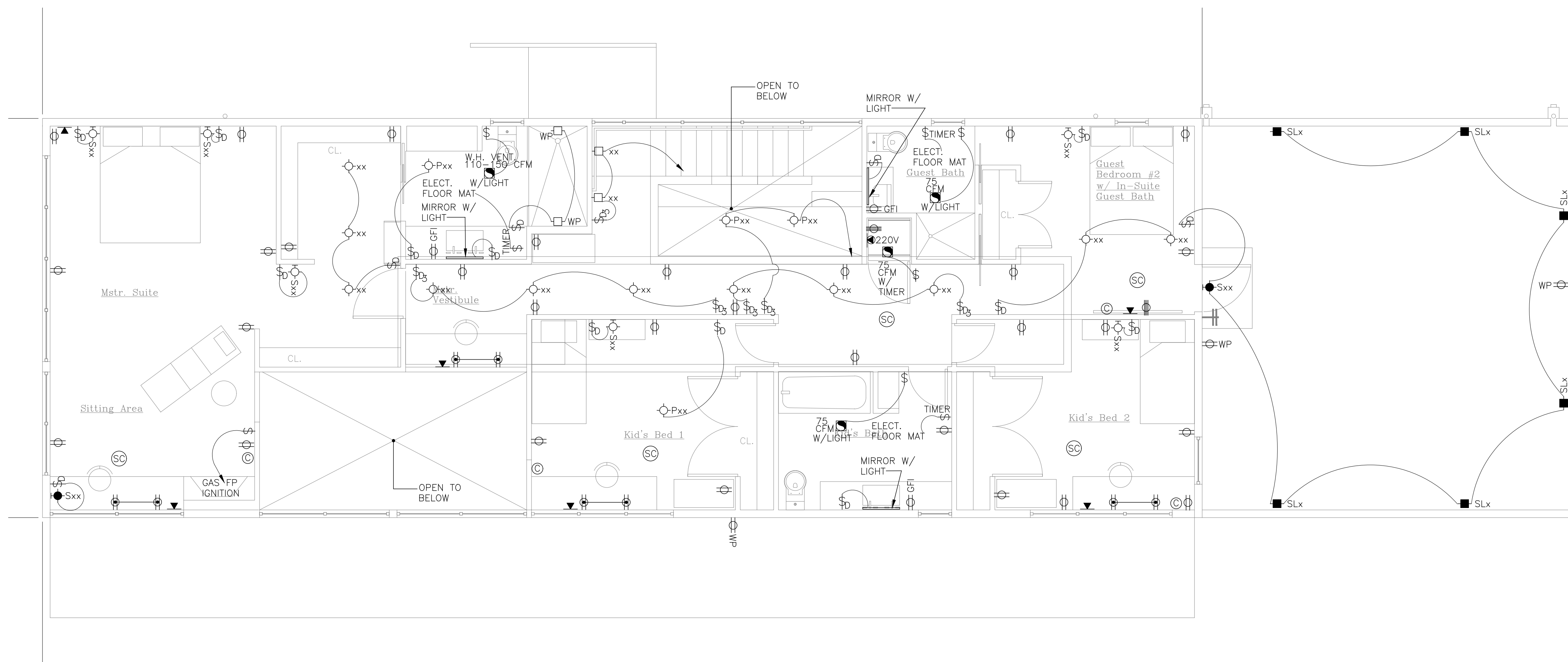

1 Upper Floor Plan
scale: 1/4"=1'-0"

- Note:
1. WHOLE HOUSE VENTILATION SHALL MEET IRC M1507.4 WHOLE HOUSE VENTILATION USING INTERMITTENT EXHAUST FANS AND FRESH AIR INLETS. A MINIMUM WHOLE HOUSE VENTILATION RATE OF 150CFM FOR EACH OF TWO DESIGNATED FANS. ALL HABITABLE ROOMS HAVE OPERABLE WINDOWS THAT MEETS AND EXCEEDS REQUIREMENTS OF IRC 1507.3.4.4.
 2. A MINIMUM OF 75% OF NEW PERMANENTLY INSTALLED LAMPS IN NEW LIGHTING FIXTURES WILL BE HIGH EFFICACY (WAC 51-11R-R404.1)
 3. EXHAUST HOOD SYSTEMS GREATER THAN A CFM OF 400 SHALL MEET THE REQUIREMENTS OF IRC M1503.4 FOR MAKE UP AIR
 4. PROVIDE @ KITCHEN AND LAUNDRY OUTLETS ACCORDING TO APPLIANCES MANUFACTURER SPECIFICATIONS.
 5. CONTRACTOR TO COORDINATE (2) WALK-THROUGHS PRIOR TO LOCATING FIXTURES, OUTLETS AND SWITCHES AND PRIOR TO FINALIZATION
 6. **ECC 3d: HIGH EFFICIENCY HVAC EQUIPMENT** PROVIDE NECESSARY CIRCUITRY FOR DUCTLESS MINI-SPLIT.

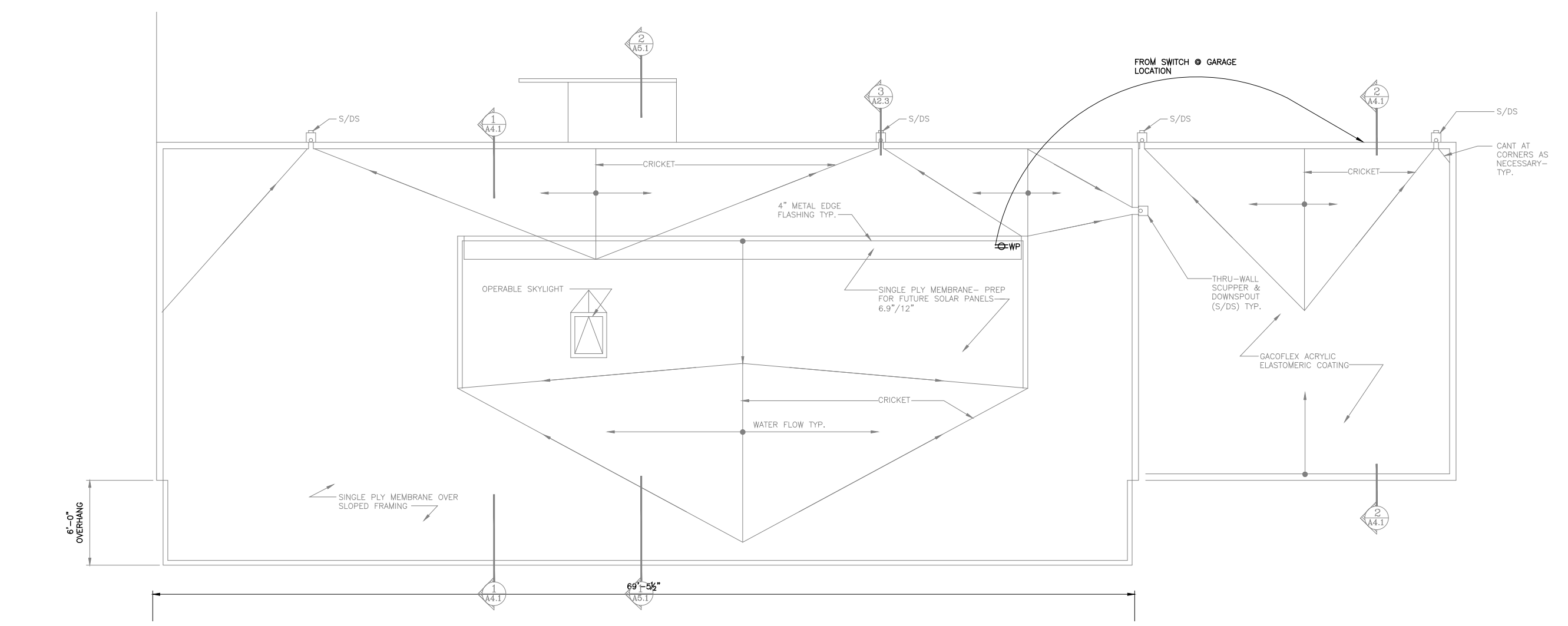

2 Roof Plan
scale: 1/8"=1'-0"

VANEY / SHINDE
New Residence
4207 West Mercer Way
Mercer Island, WA 98040

Date:
5/27/20 Permit Sub
7/15/20 Early Comm'ts
8/24/20 FND'N PERMIT
9/8/20 FND'N REVISION
10/30/20
Sub-2 2006-006

Scale:
Sheet:

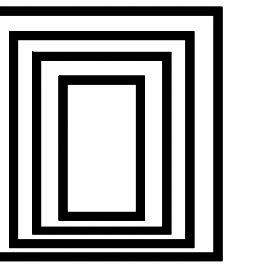

VANEY / SHINDE
 New Residence
 4207 West Mercer Way
 Mercer Island, WA 98040

GENERAL RESIDENTIAL STRUCTURAL NOTES

(THE FOLLOWING APPLY UNLESS SHOWN OTHERWISE ON THE PLANS)

CRITERIA

- ALL MATERIALS WORKMANSHIP, DESIGN, AND CONSTRUCTION SHALL CONFORM TO THE DRAWINGS, SPECIFICATIONS, AND THE 2015 INTERNATIONAL BUILDING CODE (IBC).
- DESIGN LOADING CRITERIA

SNOW LOAD	25 PSF
FLOOR LIVE LOAD (RESIDENTIAL)	40 PSF
BALCONY LIVE LOAD	60 PSF

WIND (MAIN WIND FORCE RESISTING SYSTEM) VULT = 110 MPH
 VASD = 85 MPH
 RISK CATEGORY = II
 KZT = 1.6
 EXPOSURE C, GCPI = 0.18

EARTHQUAKE (EQUIVALENT LATERAL FORCE PROCEDURE)SS=1.380, SDS =0.920
 (BASED ON 2008 USGS HAZARD DATA) SI=0.531, SD1 =0.531
 IE=1.0, SITE CLASS = D
 SEISMIC DESIGN CATEGORY= D
 RISK CATEGORY = II
 R = 6.5 FOR WOOD FRAMED SHEARWALL LATERAL SYSTEM
 OVER STRENGTH FACTOR, O_c =2.5
 REDUNDANCY FACTOR =1.0
 CS = 0.142, BASE SHEAR = $(\frac{16.5}{3})$ KIPS

SEE PLANS FOR ADDITIONAL LOADING CRITERIA $(\frac{3}{3})$ KIPS

- STRUCTURAL DRAWINGS SHALL BE USED IN CONJUNCTION WITH ARCHITECTURAL DRAWINGS FOR BIDDING AND CONSTRUCTION. CONTRACTOR SHALL VERIFY DIMENSIONS AND CONDITIONS FOR COMPATIBILITY AND SHALL NOTIFY ARCHITECT OF ANY DISCREPANCIES PRIOR TO CONSTRUCTION. ALL DIMENSIONS SHOWN ON THE STRUCTURAL DRAWINGS ARE INTENDED FOR REFERENCE ONLY. REFER TO ARCHITECTURAL DRAWINGS FOR ALL DIMENSIONS.
- CONTRACTOR SHALL VERIFY ALL EXISTING DIMENSIONS, MEMBER SIZES, AND CONDITIONS PRIOR TO COMMENCING ANY WORK. ALL DIMENSIONS OF EXISTING CONSTRUCTION SHOWN ON THE STRUCTURAL DRAWINGS ARE INTENDED AS GUIDELINES ONLY AND MUST BE VERIFIED.
- CONTRACTOR SHALL PROVIDE TEMPORARY BRACING FOR THE STRUCTURE AND STRUCTURAL COMPONENTS UNTIL ALL FINAL CONNECTIONS HAVE BEEN COMPLETED IN ACCORDANCE WITH THE PLANS.
- CONTRACTOR SHALL BE RESPONSIBLE FOR ALL SAFETY PRECAUTIONS AND THE METHODS, TECHNIQUES, SEQUENCES, OR PROCEDURES REQUIRED TO PERFORM HIS WORK. THE STRUCTURAL ENGINEER HAS NO OVERALL SUPERVISORY AUTHORITY OR ACTUAL AND/OR DIRECT RESPONSIBILITY FOR THE SPECIFIC WORKING CONDITIONS AT THE SITE AND/OR FOR ANY HAZARDS RESULTING FROM THE ACTIONS OF ANY TRADE CONTRACTOR. THE STRUCTURAL ENGINEER HAS NO DUTY TO INSPECT, SUPERVISE, NOTE, CORRECT, OR REPORT ANY HEALTH OR SAFETY DEFICIENCIES OF THE OWNER, CONTRACTORS, OR OTHER ENTITIES OR PERSONS AT THE PROJECT SITE.
- CONTRACTOR-INITIATED CHANGES SHALL BE SUBMITTED IN WRITING TO THE ARCHITECT AND STRUCTURAL ENGINEER FOR APPROVAL PRIOR TO FABRICATION OR CONSTRUCTION. CHANGES SHOWN ON SHOP DRAWINGS ONLY WILL NOT SATISFY THIS REQUIREMENT.
- DRAWINGS INDICATE GENERAL AND TYPICAL DETAILS OF CONSTRUCTION. WHERE CONDITIONS ARE NOT SPECIFICALLY INDICATED, BUT ARE OF SIMILAR CHARACTER TO DETAILS SHOWN, SIMILAR DETAILS OF CONSTRUCTION SHALL BE USED, SUBJECT TO REVIEW AND APPROVAL BY THE ARCHITECT AND THE STRUCTURAL ENGINEER.
- ALL STRUCTURAL SYSTEMS WHICH ARE TO BE COMPOSED OF COMPONENTS TO BE FIELD ERRECTED SHALL BE SUPERVISED BY THE SUPPLIER DURING MANUFACTURING, DELIVERY, HANDLING, STORAGE, AND ERECTION IN ACCORDANCE WITH INSTRUCTIONS PREPARED BY THE SUPPLIER.

GEOTECHNICAL

- FOUNDATION NOTES: SUBGRADE PREPARATION INCLUDING DRAINAGE, EXCAVATION, COMPACTION, AND FILLING REQUIREMENTS, SHALL CONFORM STRICTLY WITH RECOMMENDATIONS GIVEN IN THE SOILS REPORT OR AS DIRECTED BY THE SOILS ENGINEER. FOOTINGS SHALL BEAR ON SOLID UNDISTURBED EARTH (CONTROLLED, COMPACTED STRUCTURAL FILL OR BOTH) AT LEAST 18" BELOW LOWEST ADJACENT FINISHED GRADE. FOOTING DEPTHS/ELEVATIONS SHOWN ON PLANS (OR IN DETAILS) ARE MINIMUM AND FOR GUIDANCE ONLY; THE ACTUAL ELEVATIONS OF FOOTINGS MUST BE ESTABLISHED BY THE CONTRACTOR IN THE FIELD WORKING WITH THE TESTING LAB AND SOILS ENGINEER. BACKFILL BEHIND ALL RETAINING WALLS WITH FREE DRAINING GRANULAR FILL AND PROVIDE FOR SUBSURFACE DRAINAGE AS NOTED IN THE SOILS REPORT.

ALLOWABLE SOIL PRESSURE	2,500 PSF
LATERAL EARTH PRESSURE (UNRESTRAINED)	35 PCF
LATERAL EARTH PRESSURE (SEISMIC)	8H (ULTIMATE LOAD)
PASSIVE EARTH PRESSURE (UNFACTORED)	350 PCF
COEFFICIENT OF FRICTION (UNFACTORED)	0.40
- DRILLED CONCRETE PILES: DRILLED PILES ARE DESIGNED PER THE GEOTECHNICAL REPORT FOR UNFACTORED ACTIVE SOIL PRESSURE = 40 PCF FOR A TOTAL DEPTH OF 10 FEET AND 400 PCF FOR THE REMAINING DEPTH OF THE PILE (MINIMUM DEPTH = 30 FEET). REFER TO GEOTECHNICAL REPORT FOR ADDITIONAL INFORMATION.

SOILS REPORT REFERENCE: REPORT JN 16162, PREPARED BY GEOTECH CONSULTANTS, INC. DATED MAY 11, 2016
- AS REQUIRED BY THE THIRD-PARTY GEOTECHNICAL REVIEWER FOR THE CITY OF MERCER ISLAND, LOAD TESTS ARE REQUIRED ON 3 PERCENT OF THE INSTALLED 3-TO 4-INCH PIPE PILES UP TO A MAXIMUM OF 5 PILES, WITH A MINIMUM OF ONE PILE LOAD TEST ON EACH PROJECT. LOAD TESTING, IF REQUIRED, SHALL BE A QUICK LOAD TEST TO AT LEAST 200 PERCENT OF THE DESIGN CAPACITY, AND SHALL BE CONDUCTED IN GENERAL ACCORDANCE WITH ASTM TEST D-1143. LOAD TESTING IS NOT REQUIRED FOR 2-INCH-DIAMETER PILES OR FOR PILES THAT ARE TO BE USED FOR TEMPORARY SHORING.

AS INDICATED IN THE GEOTECHNICAL REPORT PIPE PILES DRIVEN USING HAMMERS AND DRIVING RATES SHOWN BELOW MAY BE ASSIGNED THE FOLLOWING COMPRESSIVE CAPACITIES.

3-INCH DIAMETER	FINAL DRIVING RATE	JACKHAMMER WEIGHT	CAPACITY
5-INCH DIAMETER PILE (COMPRESSION)	12 SEC/INCH	650 POUND HAMMER	6 TONS
2-INCH DIAMETER PILE (COMPRESSION)	60 SEC/INCH	90 POUND HAMMER	3 TONS

IF 140 POUND HAMMER IS USED TO INSTALL 2-INCH DIAMETER PIPE PILES THE CONTRACTOR SHALL VERIFY THE REQUIRED REFUSAL CRITERIA USING A 90 POUND HAMMER IF REQUIRED BY THE GEOTECHNICAL ENGINEER. THE DRIVING CRITERIA, FOR 3-INCH DIAMETER PILES, IS VALID ONLY FOR HYDRAULIC HAMMERS MOUNTED ON SLIDING LEADS THAT ALLOW THE HAMMER TO SIT ON TOP OF THE PILE DURING INSTALLATION.

MINIMUM PILE EMBEDMENT SHALL NOT BE LESS THAN 6'-0" AND FINAL LENGTH OF 2-INCH DIAMETER PIPE PILES SHALL NOT EXCEED 30'-0". INDIVIDUAL PILE SECTIONS SHALL BE CONNECTED USING RING COUPLERS INSTALLED BY WABO CERTIFIED WELDERS. ALTERNATE COUPLING METHODS SHALL BE SUBMITTED FOR APPROVAL PRIOR TO INSTALLATION.

STEEL PIPE SHALL CONFORM TO ASTM A-53, TYPE E OR S, GRADE B, F_y = 35 KSI. MINIMUM PILE WEIGHT FOR 2-INCH DIAMETER PIPE SHALL BE EXTRA-STONG (SCHEDULE 80) AS NOTED IN THE AISC STEEL CONSTRUCTION MANUAL. PILE WEIGHT FOR ALL OTHER PILES SHALL BE AS RECOMMENDED IN THE GEOTECHNICAL REPORT. PIPE PILES SHALL BE GALVANIZED.

PILE INSTALLATION SHALL BE OBSERVED BY THE GEOTECHNICAL ENGINEER.

CONCRETE

- CONCRETE SHALL BE MIXED, PROPORTIONED, CONVEYED, AND PLACED IN ACCORDANCE WITH THE INTERNATIONAL BUILDING CODE SECTION 1905 AND ACI 301-11. CONCRETE SHALL ATTAIN A 28-DAY STRENGTH OF F_c = 3,000 PSI, SHALL CONTAIN NO LESS THAN 5½ SACKS OF CEMENT, HAVE A MAXIMUM WATER / CEMENT RATIO OF 0.45, AND A SLUMP OF 5" OR LESS. CONCRETE HAS BEEN DESIGNED USING 2,500 PSI PER INTERNATIONAL BUILDING CODE SECTION 1705.3 EXCEPTION 2.3 TO AVOID SPECIAL INSPECTIONS.

MIX DESIGNS SHALL BE SUBMITTED TO THE STRUCTURAL ENGINEER AND BUILDING DEPARTMENT FOR APPROVAL TWO WEEKS PRIOR TO PLACING ANY CONCRETE. THE PERFORMANCE MIX SHALL INCLUDE THE AMOUNTS OF CEMENT, FINE AND COARSE AGGREGATE, WATER AND ADMIXTURES AS WELL AS THE WATER CEMENT RATIO, SLUMP, CONCRETE YIELD, AND SUBSTITUTING STRENGTH DATA IN ACCORDANCE WITH CHAPTER 5 OF ACI 318-11. THE USE OF A PERFORMANCE MIX REQUIRES BATCH PLANT INSPECTION, THE COST OF WHICH SHALL BE PAID BY THE GENERAL CONTRACTOR. REVIEW OF MIX SUBMITTALS BY THE ENGINEER OF RECORD INDICATES ONLY THAT INFORMATION PRESENTED CONFORMS TO THE CONTRACT DOCUMENTS. CONTRACTOR OR SUPPLIER MAINTAINS FULL RESPONSIBILITY FOR SPECIFIED PERFORMANCE.

ALL CONCRETE WITH SURFACES EXPOSED TO STANDING WATER SHALL BE AIR-ENTRAINED WITH AN AIR-ENTRAINING AGENT CONFORMING TO ASTM C260, C494M, AND C618. UNLESS OTHERWISE NOTED THE TOTAL AIR CONTENT FOR FROST-RESISTANT CONCRETE SHALL BE 5% IN ACCORDANCE EXPOSURE CLASS FI PER ACI 318-11 TABLE 4.3.1 AND TABLE 4.4.1.
- REINFORCING STEEL SHALL CONFORM TO ASTM A615 (INCLUDING SUPPLEMENTS S1), GRADE 60, F_y = 60,000 PSI. EXCEPTIONS: ANY BARS SPECIFICALLY SO NOTED ON THE DRAWINGS SHALL BE GRADE 40, F_y = 40,000 PSI.

WELDED WIRE FABRIC SHALL CONFORM TO ASTM A-185
- DETAILING OF REINFORCING STEEL (INCLUDING HOOKS AND BENDS) SHALL BE IN ACCORDANCE WITH ACI SP-66-04 AND 318-11. LAP ALL CONTINUOUS REINFORCEMENT #5 AND SMALLER 48 BAR DIAMETERS OR 2'-0" MINIMUM. A MAXIMUM OF ONE HALF OF THE TOTAL REINFORCEMENT SHALL BE LAPPED WITH THE REQUIRED LAP LENGTH. PROVIDE CORNER BARS AT ALL WALL AND FOOTING INTERSECTIONS. LAP ADJACENT MATS OF WELDED WIRE FABRIC A MINIMUM OF 8" AT SIDES AND ENDS.

NO BARS PARTIALLY EMBEDDED IN HARDENED CONCRETE SHALL BE FIELD BENT UNLESS SPECIFICALLY SO DETAILED OR APPROVED BY THE STRUCTURAL ENGINEER. FIELD BENDING OF GRADE 60 REINFORCEMENT SHALL NOT BE ALLOWED.
- CONCRETE PROTECTION (COVER) FOR REINFORCING STEEL SHALL BE AS FOLLOWS:

FOOTINGS AND OTHER UNFORMED SURFACES CAST AGAINST AND PERMANENTLY EXPOSED TO EARTH	3"
ALL OTHER SURFACES	1-1/2"
- SLABS-ON-GRADE: UNLESS NOTED OTHERWISE SHALL BE 4" CONCRETE, REINFORCED WITH 6X6 W1.4XW1.4 WELDED WIRE FABRIC CENTERED IN SLAB. UNLESS OTHERWISE DIRECTED BY SOILS ENGINEER PROVIDE MINIMUM 6 MIL VAPOR BARRIER OVER 4" OF COMPACTED SAND OR GRAVEL.
- CAST-IN-PLACE CONCRETE: SEE ARCHITECTURAL DRAWINGS FOR EXACT LOCATIONS AND DIMENSIONS OF DOOR AND WINDOW OPENINGS IN ALL CONCRETE WALLS. SEE ARCHITECTURAL DRAWINGS FOR ALL GROOVES, NOTCHES, CHAMFERS, FEATURE STRIPS, COLOR, TEXTURE, AND OTHER FINISH DETAILS AT ALL EXPOSED CONCRETE SURFACES.
- NON-SHRINK GROUT SHALL BE FURNISHED BY AN APPROVED MANUFACTURER AND SHALL BE MIXED AND PLACED IN STRICT ACCORDANCE WITH THE MANUFACTURER'S PUBLISHED RECOMMENDATIONS. GROUT STRENGTH SHALL BE AT LEAST EQUAL TO THE MATERIAL ON WHICH IT IS PLACED (3,000 PSI MINIMUM).

POST INSTALLED ANCHORS

- POST-INSTALLED ANCHORS SHALL ONLY BE USED WHERE SPECIFIED ON THE CONSTRUCTION DOCUMENTS. THE CONTRACTOR SHALL OBTAIN APPROVAL FROM THE ENGINEER-OF-RECORD PRIOR TO INSTALLING POST-INSTALLED ANCHORS IN PLACE OF MISSING OR MISPLACED CAST-IN-PLACE ANCHORS. CARE SHALL BE TAKEN IN PLACING POST-INSTALLED ANCHORS TO AVOID CONFLICTS WITH EXISTING REINFORCEMENT. HOLES SHALL BE DRILLED AND CLEANED IN ACCORDANCE WITH THE MANUFACTURER'S WRITTEN INSTRUCTIONS AND ICC-ES REPORT. SUBSTITUTION REQUESTS, FOR PRODUCTS OTHER THAN THOSE SPECIFIED BELOW, SHALL BE SUBMITTED BY THE CONTRACTOR TO THE ENGINEER-OF-RECORD FOR APPROVAL.

A. CONCRETE ANCHORS
 20.1.1.1. ADHESIVE ANCHORS FOR USE IN CRACKED AND UNCRACKED CONCRETE SHALL HAVE BEEN TESTED AND QUALIFIED FOR USE IN ACCORDANCE WITH ICC-ES AC308. PRE-APPROVED ADHESIVE ANCHORS INCLUDE:
 a. SIMPSON STRONG-TIE "SET-XP" (ICC-ES ESR-2508)
 b. SIMPSON STRONG-TIE "AT-XP" (AFMO UES ER-263)
 c. HILTI HIT-RE 500-SD (ICC-ES ESR-2322)

STEEL

- STRUCTURAL STEEL DESIGN, FABRICATION, AND ERECTION SHALL BE BASED ON THE LATEST EDITIONS OF THE AMERICAN INSTITUTE OF STEEL CONSTRUCTION (AISC) CODES AND SPECIFICATIONS. ALL WELDING SHALL CONFORM TO THE AMERICAN WELDING SOCIETY STRUCTURAL WELDING CODE D1.1 AND D1.4.
- STRUCTURAL STEEL SHALL CONFORM TO THE FOLLOWING REQUIREMENTS:

TYPE OF MEMBER	ASTM SPECIFICATION	F _y
A. PLATES, ANGLES, AND ROHS	A36	36 KSI
B. WIDE FLANGE SHAPES AND CHANNELS	A992	50 KSI
C. PIPE COLUMNS	A53 (TYPE E OR S, GRADE B)	35 KSI
D. STRUCTURAL TUBING (SQUARE OR RECTANGULAR)	A500 (GRADE B)	46 KSI
E. ANCHOR BOLTS (EMBEDDED IN MASONRY OR CONCRETE)	A307	
F. CONNECTION BOLTS	A325-N OR A490-N	
(3/4" ROUND, UNLESS SHOWN OTHERWISE)		
G. THREADED RODS FOR EPOXY GROUTED CONNECTIONS	A36 OR A307 GRADE C	36 KSI
- ALL A-325 CONNECTION BOLTS SHALL BE INSTALLED TO THE SNUG-TIGHT CONDITION PER AISC SPECIFICATIONS. INSTALL IN STRICT ACCORDANCE WITH THE MANUFACTURER'S PUBLISHED RECOMMENDATIONS.
- ALL WELDING SHALL BE IN CONFORMANCE WITH AISC AND A.W.S. STANDARDS AND SHALL BE PERFORMED BY WABO CERTIFIED WELDERS USING E70 XX ELECTRODES UNLESS OTHERWISE NOTED. ONLY PREQUALIFIED WELDS (AS DEFINED BY A.W.S.) SHALL BE USED.

WOOD

- FRAMING LUMBER SHALL BE KILN DRIED OR MC-19, AND GRADED AND MARKED IN CONFORMANCE WITH W.C.L.I.B. STANDARD GRADING RULES FOR WEST COAST LUMBER NO. 17, LATEST EDITION. FURNISH TO THE FOLLOWING MINIMUM STANDARDS.

JOISTS:	HEM-FIR NO. 2
(2X, 3X, AND 4X MEMBERS)	MINIMUM BASE VALUE, F _B = 850 PSI
<u>BEAM AND STRINGERS:</u>	DOUGLAS FIR NO. 1
(6 X AND LARGER MEMBERS)	MINIMUM BASIC DESIGN STRESS, F _B = 1,350 PSI
<u>POSTS AND TIMBERS:</u>	DOUGLAS FIR NO. 1
(6 X AND LARGER MEMBERS)	MINIMUM BASIC DESIGN STRESS, F _B = 1,200 PSI, F _C = 1,000 PSI
<u>STUDS, PLATES & MISCELLANEOUS LIGHT FRAMING</u>	DOUGLAS FIR/ HEM-FIR NO. 2, F _B = 850 PSI, F _C = 1,300 PSI
(FINGER JOINTED STUDS MAY NOT BE USED WITH APPROVAL FROM STRUCTURAL ENGINEER)	
<u>2X AND 3X TONGUE AND GROOVE DECKING</u>	HEM-FIR COMMERCIAL DEX, F _B = 1,350 PSI
- PARALLEL STRAND LUMBER (PSL): EACH PIECE SHALL BEAR A STAMP OR STAMPS NOTING THE NAME AND PLANT NUMBER OF THE MANUFACTURER, THE GRADE, PRODUCT DESIGNATION OR TYPE, THE PRODUCTION DATE, SPECIES OR SPECIES GROUP DESIGNATION, AND THE QUALITY CONTROL AGENCY. MEMBERS SHALL BE GLUED WITH A WATERPROOF ADHESIVE MEETING THE REQUIREMENTS OF ASTM D2559 WITH ALL GRAIN PARALLEL WITH THE LENGTH OF THE MEMBER. STRUCTURAL CAPACITIES SHALL BE ESTABLISHED IN ACCORDANCE WITH ASTM D5456 AND PRODUCT SHALL HAVE AN APPROVED I.C.C.-E.S. EVALUATION REPORT. MEMBERS SHALL BE TRANSPORTED AND STORED PER MANUFACTURERS RECOMMENDATIONS AND SHALL NOT BE EXPOSED TO PROLONGED MOISTURE. MINIMUM REQUIRED DESIGN PROPERTIES: F_B = 2900 PSI, E = 2,000,000 PSI, F_v = 290 PSI.

DESIGN SHOWN ON PLANS IS BASED ON LUMBER MANUFACTURED BY THE WEYERHAEUSER. ALTERNATE MANUFACTURERS MAY BE USED SUBJECT TO REVIEW AND APPROVAL BY THE ARCHITECT AND STRUCTURAL ENGINEER. ALTERNATE JOIST HANGERS AND OTHER HARDWARE MAY BE SUBSTITUTED FOR ITEMS SHOWN PROVIDED THEY HAVE ICC-ES APPROVAL FOR EQUAL OR GREATER LOAD CAPACITIES. ALL JOIST HANGERS AND OTHER HARDWARE SHALL BE COMPATIBLE IN SIZE WITH MEMBERS PROVIDED.
- LAMINATED VENEER LUMBER (LVL): EACH PIECE SHALL BEAR A STAMP OR STAMPS NOTING THE NAME AND PLANT NUMBER OF THE MANUFACTURER, THE GRADE, PRODUCT DESIGNATION OR TYPE, THE PRODUCTION DATE, SPECIES OR SPECIES GROUP DESIGNATION, AND THE QUALITY CONTROL AGENCY. MEMBERS SHALL BE GLUED WITH A WATERPROOF ADHESIVE MEETING THE REQUIREMENTS OF ASTM D2559 WITH ALL GRAIN PARALLEL WITH THE LENGTH OF THE MEMBER. STRUCTURAL CAPACITIES SHALL BE ESTABLISHED IN ACCORDANCE WITH ASTM D5456 AND PRODUCT SHALL HAVE AN APPROVED I.C.C.-E.S. EVALUATION REPORT. MEMBERS SHALL BE TRANSPORTED AND STORED PER MANUFACTURERS RECOMMENDATIONS AND SHALL NOT BE EXPOSED TO PROLONGED MOISTURE. MINIMUM REQUIRED DESIGN PROPERTIES: F_B = 2600 PSI, F_v = 285 PSI, E = 2,000,000 PSI.

DESIGN SHOWN ON PLANS IS BASED ON LUMBER MANUFACTURED BY WEYERHAEUSER. ALTERNATE MANUFACTURERS MAY BE USED SUBJECT TO REVIEW AND APPROVAL BY THE ARCHITECT AND STRUCTURAL ENGINEER, ALTERNATE JOIST HANGERS AND OTHER HARDWARE MAY BE SUBSTITUTED FOR ITEMS SHOWN PROVIDED THEY HAVE ICC-ES APPROVAL FOR EQUAL OR GREATER LOAD CAPACITIES. ALL JOIST HANGERS AND OTHER HARDWARE SHALL BE COMPATIBLE IN SIZE WITH MEMBERS PROVIDED.
- LAMINATED STRAND LUMBER (LSL): EACH PIECE SHALL BEAR A STAMP OR STAMPS NOTING THE NAME AND PLANT NUMBER OF THE MANUFACTURER, THE GRADE, PRODUCT DESIGNATION OR TYPE, THE PRODUCTION DATE, SPECIES OR SPECIES GROUP DESIGNATION, AND THE QUALITY CONTROL AGENCY. MEMBERS SHALL BE GLUED WITH A WATERPROOF ADHESIVE MEETING THE REQUIREMENTS OF ASTM D2559 WITH ALL GRAIN PARALLEL WITH THE LENGTH OF THE MEMBER. STRUCTURAL CAPACITIES SHALL BE ESTABLISHED IN ACCORDANCE WITH ASTM D5456 AND PRODUCT SHALL HAVE AN APPROVED I.C.C.-E.S. EVALUATION REPORT. MEMBERS SHALL BE TRANSPORTED AND STORED PER MANUFACTURERS RECOMMENDATIONS AND SHALL NOT BE EXPOSED TO PROLONGED MOISTURE. MINIMUM REQUIRED DESIGN PROPERTIES: F_B = 2325 PSI, F_v = 310 PSI, E = 1,550,000 PSI.

DESIGN SHOWN ON PLANS IS BASED ON LUMBER MANUFACTURED BY WEYERHAEUSER. ALTERNATE MANUFACTURERS MAY BE USED SUBJECT TO REVIEW AND APPROVAL BY THE ARCHITECT AND STRUCTURAL ENGINEER, ALTERNATE JOIST HANGERS AND OTHER HARDWARE MAY BE SUBSTITUTED FOR ITEMS SHOWN PROVIDED THEY HAVE ICC-ES APPROVAL FOR EQUAL OR GREATER LOAD CAPACITIES. ALL JOIST HANGERS AND OTHER HARDWARE SHALL BE COMPATIBLE IN SIZE WITH MEMBERS PROVIDED.
- PREFABRICATED PLYWOOD WEB JOIST DESIGN SHOWN ON PLANS IS BASED ON JOIST MANUFACTURED BY THE WEYERHAEUSER. ALTERNATE PLYWOOD WEB JOIST MANUFACTURERS MAY BE USED SUBJECT TO REVIEW AND APPROVAL BY THE ARCHITECT AND STRUCTURAL ENGINEER. ALTERNATE JOIST HANGERS AND OTHER HARDWARE MAY BE SUBSTITUTED FOR ITEMS SHOWN PROVIDED THEY HAVE ICC-ES APPROVAL FOR EQUAL OR GREATER LOAD CAPACITIES. ALL JOIST HANGERS AND OTHER HARDWARE SHALL BE COMPATIBLE IN SIZE WITH PLYWOOD WEB JOIST PROVIDED.
- PLYWOOD SHEATHING SHALL BE GRADE C-D, EXTERIOR GLUE OR STRUCTURAL II, EXTERIOR GLUE IN CONFORMANCE WITH DOC PS 1-09 OR PS 2-10 AND AMERICAN PLYWOOD ASSOCIATION PERFORMANCE STANDARD PRP-108. ORIENTED STRAND BOARD OF EQUIVALENT THICKNESS, EXPOSURE RATING AND PANEL INDEX MAY BE USED IN LIEU OF PLYWOOD. SEE PLANS FOR THICKNESS, PANEL IDENTIFICATION INDEX AND NAILING REQUIREMENTS. EACH PANEL SHALL BE IDENTIFIED FOR GRADE AND GLUE TYPE BY THE TRADEMARKS OF AN APPROVED TESTING AND GRADING AGENCY.
- ALL WOOD PLATES IN DIRECT CONTACT WITH CONCRETE OR MASONRY SHALL BE PRESSURE-TREATED WITH AN APPROVED PRESERVATIVE, PROVIDE 2 LAYERS OF ASPHALT IMPREGNATED BUILDING PAPER BETWEEN UNTREATED LEDGERS, BLOCKING, ETC. AND CONCRETE OR MASONRY.

PRESSURE TREATED LUMBER SHALL COMPLY WITH THE AMERICAN WOOD PROTECTION ASSOCIATION (AWPA) STANDARD U1, COMMODITY SPECIFICATION A AS INDICATED BELOW OR HAVE EQUIVALENT ICC-ES APPROVAL.

PROPOSED USE	AWPA USE CATEGORY
RESIDENTIAL DECKS	DECKING 3B
	JOISTS ABOVE GROUND 3B
	JOISTS IN CONTACT WITH GROUND 4A
	POSTS 4A
	RAILING 3B
	LEDGERS 3B
SILL PLATES	IN CONTACT WITH CONCRETE OR MASONRY 2

ALL TREATED LUMBER SHALL BEAR THE QUALITY MARK OF AN ACCREDITED INSPECTION AGENCY. THE QUALITY MARK SHALL INCLUDE:

- IDENTIFICATION OF TREATING MANUFACTURER
- TYPE OF PRESERVATIVE USED
- MINIMUM PRESERVATIVE RETENTION (PCF)
- END USE FOR WHICH THE PRODUCT IS TREATED
- IDENTITY OF THE ACCREDITED INSPECTION AGENCY
- STANDARD TO WHICH THE PRODUCT IS TREATED

- TIMBER CONNECTORS CALLED OUT BY LETTERS AND NUMBERS SHALL BE "STRONG-TIE" BY SIMPSON COMPANY, AS SPECIFIED IN THEIR CATALOG NUMBER C-2013. EQUIVALENT DEVICES BY OTHER MANUFACTURERS MAY BE SUBSTITUTED, PROVIDED THEY HAVE ICC-ES APPROVAL FOR EQUAL OR GREATER LOAD CAPACITIES. PROVIDE NUMBER AND SIZE OF FASTENERS AS SPECIFIED BY MANUFACTURER. CONNECTORS SHALL BE INSTALLED IN ACCORDANCE WITH THE MANUFACTURER'S RECOMMENDATIONS. WHERE CONNECTOR STRAPS CONNECT TWO MEMBERS, PLACE ONE-HALF OF THE NAILS OR BOLTS IN EACH MEMBER. ALL BOLTS IN WOOD MEMBERS SHALL CONFORM TO ASTM A307. PROVIDE WASHERS UNDER THE HEADS AND NUTS OF ALL BOLTS AND LAG SCREWS BEARING ON WOOD. UNLESS NOTED OTHERWISE, ALL NAILS SHALL BE COMMON AND MAXIMUM NUMBER OF NAILS AS SPECIFIED BY THE MANUFACTURER SHALL BE PROVIDED. ALL SHIMS SHALL BE SEASONED AND DRIED AND THE SAME GRADE (MINIMUM) AS MEMBERS CONNECTED. ALL SAWN LUMBER JOISTS SHALL BE CONNECTED TO FLUSH BEAMS WITH "LUS" SERIES JOIST HANGERS AND ALL PREFABRICATED PLYWOOD WEB JOISTS SHALL BE CONNECTED TO FLUSH BEAMS WITH "IUS" SERIES JOIST HANGERS UNLESS NOTED OTHERWISE.

ALL CONNECTIONS IN CONTACT WITH PRESERVATIVE-TREATED OR FIRE-RETARDANT-TREATED WOOD, SHALL BE OF HOT DIPPED ZINC-COATED GALVANIZED STEEL OR STAINLESS STEEL. HOT DIPPED GALVANIZED FASTENERS SHOULD CONFORM TO ASTM STANDARD 153, AND HOT DIPPED GALVANIZED CONNECTORS SHOULD CONFORM TO ASTM STANDARD A653 (CLASS G-185). STAINLESS STEEL FASTENERS AND CONNECTORS SHOULD BE TYPE 304 OR 316. NOTE: ELECTROPLATED GALVANIZED FASTENERS AND CONNECTORS ARE NOT TO BE USED WITH PRESSURE TREATED WOOD. SIMPSON PRODUCT FINISHES CORRESPONDING TO THE ABOVE REQUIREMENTS ARE ZN48 (HOT DIPPED GALVANIZED) AND S5300 (STAINLESS STEEL). STAINLESS STEEL HARDWARE AND FASTENERS SHALL NOT BE COMBINED WITH UNTREATED OR GALVANIZED MATERIAL.

WOOD FASTENERS

A. NAIL SIZES SPECIFIED ON DRAWINGS ARE BASED ON THE FOLLOWING SPECIFICATIONS:

SIZE	LENGTH	DIAMETER
8D	2-1/2"	0.131"
10D	3"	0.148"
12D	3-1/4"	0.148"
16D	3-1/2"	0.162"

8D	2-1/2"	0.131"
10D	3"	0.148"
12D	3-1/4"	0.148"
16D	3-1/2"	0.162"

DESIGN IS BASED ON COMMON STEEL WIRE NAILS MEETING THE REQUIREMENTS OF ASTM F1667. USE OF ALTERNATE FASTENERS MUST BE SUBMITTED FOR REVIEW AND APPROVAL BY THE STRUCTURAL ENGINEER PRIOR TO THE START OF CONSTRUCTION.

B. NAILS - PLYWOOD (APA RATED SHEATHING) FASTENERS TO FRAMING SHALL BE DRIVEN FLUSH TO FACE OF SHEATHING WITH NO COUNTERSINKING PERMITTED.

WOOD FRAMING NOTES - THE FOLLOWING APPLY UNLESS OTHERWISE SHOWN ON THE PLANS:

A. ALL WOOD FRAMING DETAILS NOT SHOWN OTHERWISE SHALL BE CONSTRUCTED TO THE MINIMUM STANDARDS OF THE INTERNATIONAL BUILDING CODE. MINIMUM NAILING UNLESS OTHERWISE NOTED SHALL CONFORM TO TABLE 2304.9.1 OF THE INTERNATIONAL BUILDING CODES UNLESS OTHERWISE NOTED AND ALL NAILS SHALL BE AS SPECIFIED ABOVE. COORDINATE THE SIZE AND LOCATION OF ALL OPENINGS WITH MECHANICAL AND ARCHITECTURAL DRAWINGS. PROVIDE WASHERS UNDER THE HEADS AND NUTS OF ALL BOLTS AND LAG SCREWS BEARING ON WOOD. INSTALLATION OF BOLTS AND LAG SCREWS SHALL CONFORM TO SECTIONS 11.1.2 AND 11.1.3 OF THE 2015 NATIONAL DESIGN SPECIFICATION FOR WOOD CONSTRUCTION. NATURALLY DURABLE OR PRESSURE TREATED WOOD SHALL BE PROVIDED WHERE REQUIRED BY SECTION 2304.11 OF THE INTERNATIONAL BUILDING CODE.

B. WALL FRAMING: ALL STUD WALLS SHOWN AND NOT OTHERWISE NOTED SHALL BE 2X6 AT 16" O.C. TWO STUDS MINIMUM SHALL BE PROVIDED AT THE END OF ALL WALLS AND AT EACH SIDE OF ALL OPENINGS. TWO 2 X 8 HEADERS SHALL BE PROVIDED OVER ALL OPENINGS NOT OTHERWISE NOTED AND SHALL BEAR FULLY ON A MINIMUM OF TWO STUDS. SOLID BLOCKING FOR WOOD COLUMNS SHALL BE PROVIDED THROUGH FLOORS TO SUPPORTS BELOW. PROVIDE SOLID BLOCKING BETWEEN STUDS AT MID-HEIGHT OF ALL STUD WALLS OVER 10' IN HEIGHT.

STUDS MAY BE NOTCHED, CUT, OR PENETRATED WITH ROUND BORED HOLES AS FOLLOWS:

STUD SIZE	MAXIMUM NOTCH / CUT	MAXIMUM BORED HOLE
2X4	7/8"	1-3/8"
2X6	1-3/8"	2-1/8"

BORED HOLES SHALL NOT BE LOCATED WITH 5/8" FROM THE EDGE OF THE STUD OR AT THE SAME LOCATION AS A NOTCH OR CUT.

WALLS SHALL HAVE A SINGLE BOTTOM PLATE AND A DOUBLE TOP PLATE. END NAIL TOP PLATE TO EACH STUD WITH TWO 16D NAILS, AND TOENAIL OR END NAIL EACH STUD TO BOTTOM PLATE WITH TWO 16D NAILS. FACE NAIL DOUBLE TOP PLATE WITH 16D AT 12" O.C. AND LAP MINIMUM 4'-0" AT JOINTS AND PROVIDE EIGHT 16D NAILS AT 4" O.C. EACH SIDE OF JOINT.

ALL STUD WALLS SHALL HAVE THEIR LOWER WOOD PLATES ATTACHED TO WOOD FRAMING BELOW WITH 16D NAILS AT 12" O.C. STAGGERED OR BOLTED TO CONCRETE WITH 5/8" DIAMETER ANCHOR BOLTS (WITH 2" MINIMUM EMBEDMENT) @ 4'-0" O.C. UNLESS INDICATED OTHERWISE. PROVIDE 3X3" X1/4" HOT-DIPPED GALVANIZED PLATE WASHERS AT ALL ANCHOR BOLTS. INDIVIDUAL MEMBERS OF BUILT-UP POSTS SHALL BE NAILED TO EACH OTHER WITH 16D NAILS @ 12" O.C. STAGGERED. REFER TO THE PLANS AND SHEAR WALL SCHEDULE FOR REQUIRED SHEATHING AND NAILING. WHEN NOT OTHERWISE NOTED, PROVIDE GYPSUM WALLBOARD ON INTERIOR SURFACES NAILED TO ALL STUDS, TOP AND BOTTOM PLATES AND BLOCKING WITH NAILS AT 7" O.C. USE 50 COOLER NAILS FOR 1/2" GWB AND 60 COOLER NAILS FOR 5/8" GWB. PROVIDE 15/32" APA RATED SHEATHING (SPAN RATING 24/0) ON EXTERIOR SURFACES NAILED AT ALL PANEL EDGES (BLOCK UNSUPPORTED EDGES), TOP AND BOTTOM PLATES WITH 8D NAILS @ 6" O.C. AND TO ALL INTERMEDIATE STUDS AND BLOCKING WITH NAILS @ 12" O.C. ALLOW 1/8" SPACING AT ALL PANEL EDGES AND ENDS.

C. FLOOR AND ROOF FRAMING: PROVIDE DOUBLE JOISTS UNDER ALL PARALLEL PARTITIONS THAT EXTEND OVER MORE THAN HALF THE JOIST LENGTH AND AROUND ALL OPENINGS IN FLOORS OR ROOFS UNLESS OTHERWISE NOTED. PROVIDE SOLID BLOCKING AT ALL BEARING POINTS.

NOTCHES AT THE END OF JOISTS AND RAFTERS SHALL NOT EXCEED 1/4 THE DEPTH OF THE MEMBER. NOTCHES IN THE TOP OR BOTTOM SHALL NOT EXCEED 1/6 THE DEPTH OF THE MEMBER AND SHALL NOT BE LOCATED WITHIN THE MIDDLE 1/3 OF THE SPAN. THE DIAMETER OF ROUND HOLES BORED IN JOISTS AND RAFTERS SHALL NOT EXCEED 1/3 OF THE DEPTH OF THE MEMBER AND SHALL NOT BE LOCATED WITHIN 2' FROM THE TOP OR BOTTOM EDGE.

TOENAIL JOISTS TO SUPPORTS WITH TWO 16D NAILS. ATTACH TIMBER JOISTS TO FLUSH HEADERS OR BEAMS WITH SIMPSON METAL JOIST HANGERS IN ACCORDANCE WITH NOTES ABOVE. NAIL ALL MULTI-JOIST BEAMS TOGETHER WITH TWO ROWS OF 16D @ 12" O.C. ATTACH RAFTERS AT BEARING LINES WITH H2.5 @ 24" O.C. UNLESS OTHER METAL CONNECTIONS ARE PROVIDED.

UNLESS OTHERWISE NOTED ON THE PLANS, APA RATED ROOF AND FLOOR SHEATHING SHALL BE LAID UP WITH STRENGTH AXIS PERPENDICULAR TO SUPPORTS AND NAILED WITH NAILS @ 6" O.C. TO FRAMED PANEL EDGES AND OVER STUD WALLS AS SHOWN ON PLANS AND @ 12" O.C. TO INTERMEDIATE SUPPORTS. PROVIDE APPROVED PLYWOOD EDGE CLIPS CENTERED BETWEEN JOISTS/TRUSSES AT UNBLOCKED ROOF SHEATHING EDGES. ALL FLOOR SHEATHING EDGES SHALL HAVE APPROVED TONGUE_AND_GROOVE JOINTS OR SHALL BE SUPPORTED WITH SOLID BLOCKING. ALLOW 1/8" SPACING AT ALL PANEL EDGES AND ENDS OF ALL ROOF AND FLOOR SHEATHING. TOENAIL BLOCKING TO SUPPORTS WITH 16D @ 12" O.C. UNLESS OTHERWISE NOTED. AT BLOCKED FLOOR AND ROOF DIAPHRAGMS PROVIDE FLAT 2X BLOCKING AT ALL UNFRAMED PLYWOOD PANEL EDGES AND NAIL WITH EDGE NAILING SPECIFIED.

TONGUE AND GROOVE STRUCTURAL ROOF AND FLOOR DECKING SHALL BE INSTALLED AS FOLLOWS:

2X DECKING SHALL BE TOENAILED THROUGH THE TONGUE AND FACE NAILED WITH ONE 16D NAIL PER PIECE PER SUPPORT.

3X AND 4X DECKING SHALL BE TOENAILED WITH ONE 40D NAIL AND FACE NAILED WITH ONE 60D NAIL PER SUPPORT. COURSES SHALL BE SPIKED TOGETHER WITH 8" SPIKES AT 30" O.C. (MAXIMUM) AND AT 10" (MAXIMUM) FROM EACH END OF EACH PIECE. SPIKES SHALL BE INSTALLED IN PREDRILLED EDGE HOLES.

Date:
 5/27/20 Permit Sub
 7/15/20 Early Comm
 8/24/20 FND N PERMIT
 9/8/20 FND N REVISION
 10/30/20
 Sub-2 2006-006

Scale:
 Sheet:



VANEY / SHINDE
 New Residence
 4207 West Mercer Way
 Mercer Island, WA 98040

(15) 3" PIN-PILES @ 8'-0" OC MAX, REFER PLAN NOTE #3
 BATTER PILES PER 5/S5.1

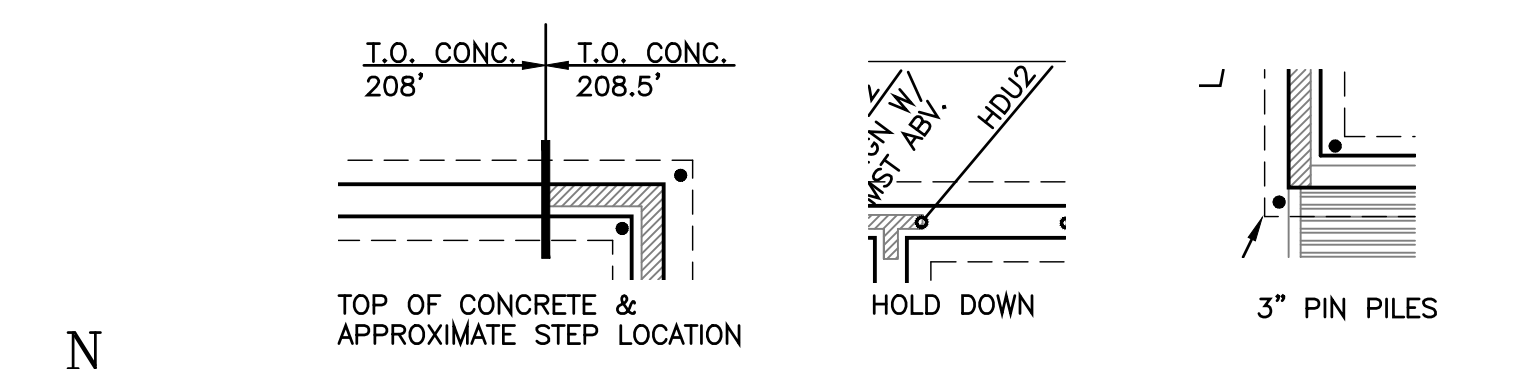
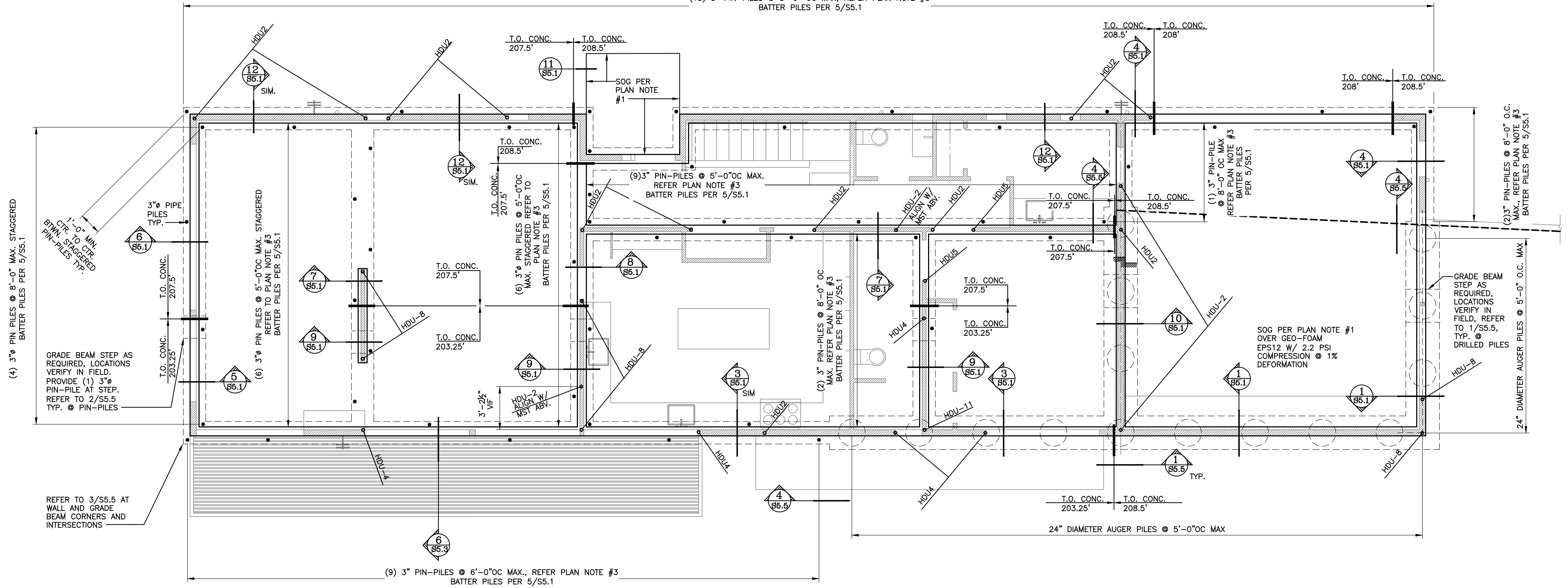

1 Foundation Plan
 scale: 1/4"=1'-0"
Foundation Plan Notes
 1. All slabs-on-grade shall be 4" reinforced with WWF6x6 W1.4xW1.4 u.n.o. Provide minimum 6-mil visqueen vapor barrier under all slabs. Slabs shall be supported on a minimum 4 inches of free draining material.
 2. Refer to Typical Hold-down Schedule, detail 2/S2.1 for hold-down anchors, embedments, and minimum stud sizes. All anchors shall be installed as required by manufacturer. Minimum (2) 2x studs unless otherwise noted on schedule.
 3. Pin-piles shall be XS, extra-strong (schedule 80). Refer to General Structural Notes for construction and testing criteria.
 Pin-piles shall be staggered. Refer to plan for quantities and maximum spacing. Refer to s0.1 for installation notes and s5.1 foundation details for additional information.

Typical Hold Down Detail-Schedule

PLAN MARK	ANCHOR BOLT	EPOXY BOLT	ALL THREAD W/* NUT/WASHER/NUT	NO. DF STUDS
HDU 2	3/8"	7"	7"	(2)
HDU 4	3/8"	10"	7"	(2)
HDU 5	3/8"	-	12"	(2)
HDU 8	7/8"	-	12"	(3)
HDU 11	1"	-	12"	4x6
HDU 14	1"	-	18"	4x8 (or 6x6)

* WHERE NO EPOXY EMBED DEPTH IS PROVIDED, ANCHOR SHALL BE CAST-IN-PLACE.

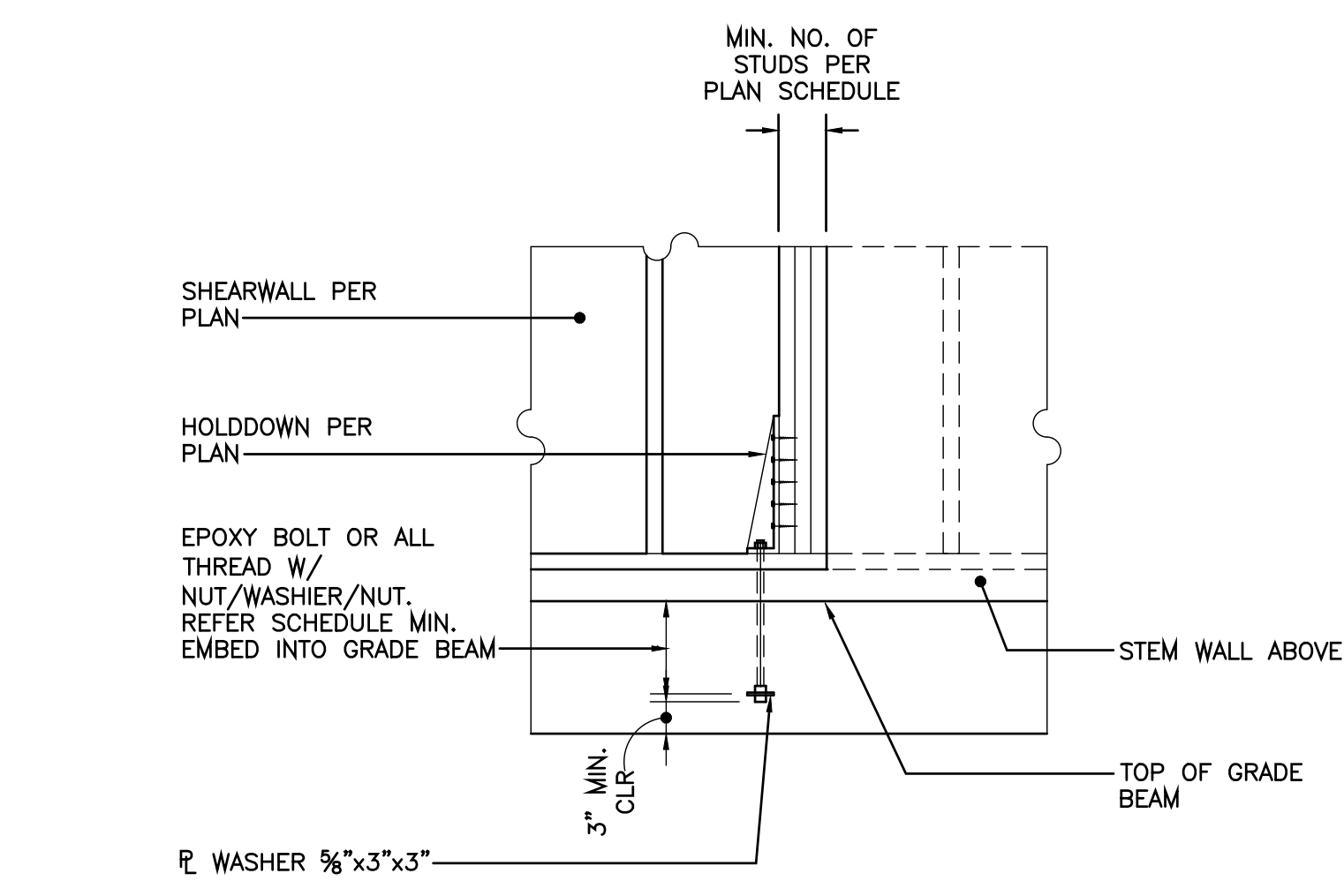

2 Typical Holddown Detail
 scale: 3/4"=1'-0"

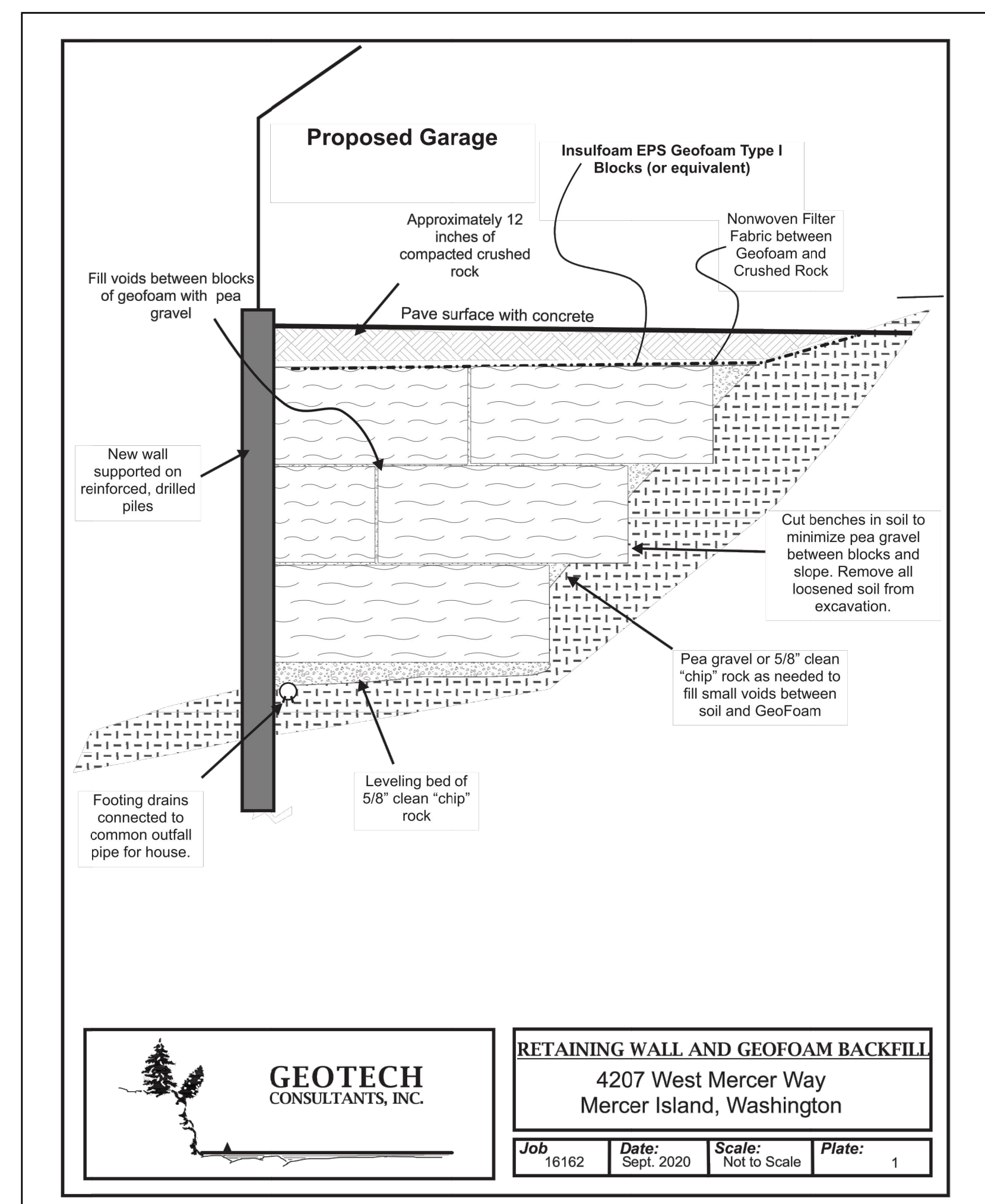

GEOTECH CONSULTANTS, INC.
 4207 West Mercer Way
 Mercer Island, Washington

Job: 16162	Date: Sept. 2020	Scale: Not to Scale	Plate: 1
------------	------------------	---------------------	----------

Date:
 5/27/20 Permit Sub
 7/15/20 Early Com ts
 8/24/20 FND'N PERMIT
 9/8/20 FND'N REVISION
 10/30/20
 Sub-2 2008-006

Scale:
 Sheet:

Foundation Plan
 S2.0

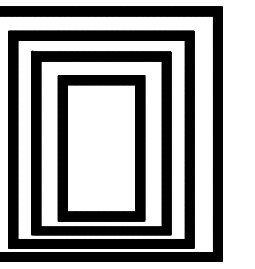

VANEY / SHINDE
New Residence
4207 West Mercer Way
Mercer Island, WA 98040

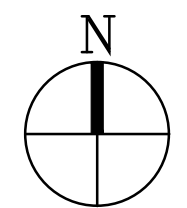
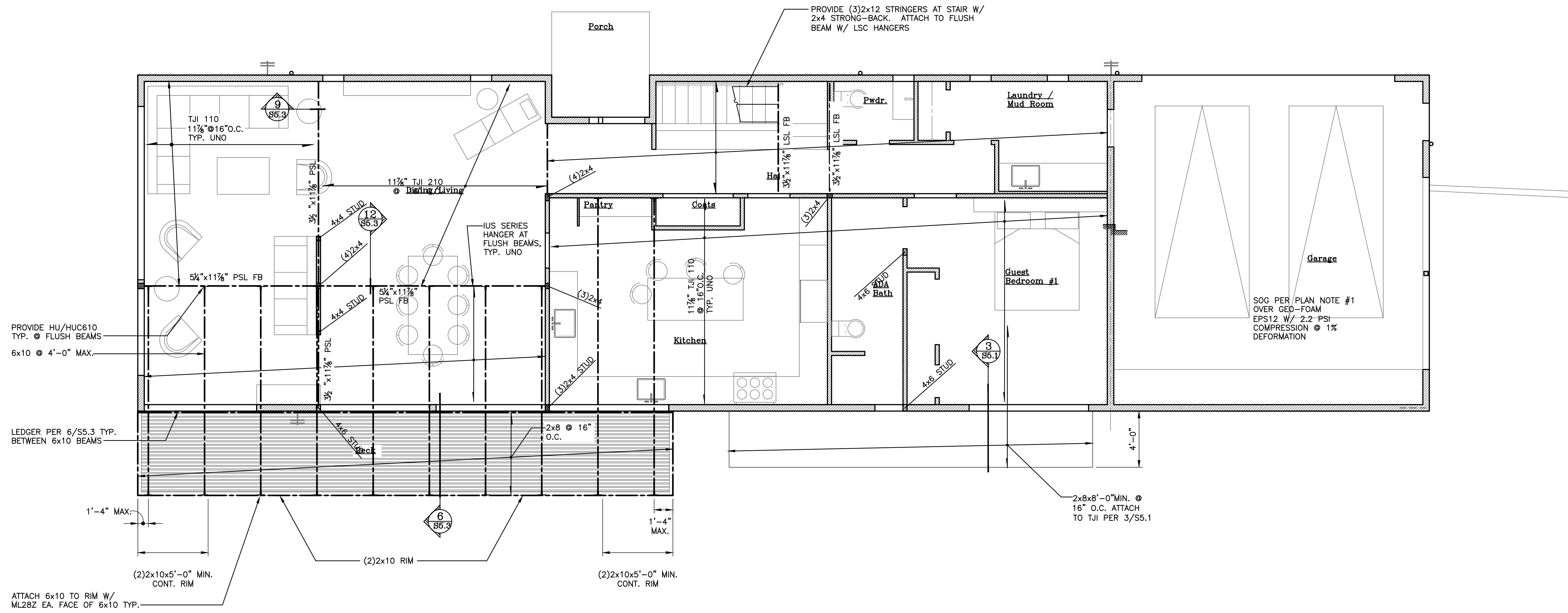

1 Main Floor Framing
Scale: 1/4"=1'-0"

Notes:
ALL EXPOSED DECK FRAMING SHALL BE PRESSURE TREATED PER GENERAL STRUCTURAL NOTES

Mark	Sheathing	Bld'g	Panel Nailing ¹	Attachment to top plate ²	Bottom Plate Attachment			Capacity (p/f) (Seismic)
					Rim Joist Req'd	Nailing to wood below	A. Bolts to concrete below	
SW 1	15/32" APA Sheathing	Yes	8d @ 6" oc	CLIP @ 24" oc	2x or 1 1/4" LSL	16d @ 6" oc	5/8" @ 48" oc	240
SW 2	15/32" APA Sheathing	Yes	8d @ 4" oc	CLIP @ 20" oc	2x or 1 1/4" LSL	16d @ 4" oc	5/8" @ 48" oc	355
SW 3	15/32" APA Sheathing	Yes	8d @ 3" oc	CLIP @ 16" oc	2x or 1 1/4" LSL	16d @ 3" oc	5/8" @ 36" oc	455
SW 4	15/32" APA Sheathing	Yes	8d @ 2" oc	CLIP @ 12" oc	4x or 3 1/2" LSL	(2) Rows ⁴ 16d @ 5 1/4" oc	5/8" @ 24" oc	595

¹ Nails shall be 8d box. Nailing applies to all panel edges (block all unsupported panel edges), top & bottom plates and blocking. Nail to intermediate framing members w/ 8d @ 12" oc. (Note: where stud spacing is 24" oc, nail to intermediate framing members with 8d @ 6" oc.)
² Framing at adjoining panel edges shall be 3-inch nominal or wider and nails shall be staggered.
³ Clip shall be either A35, LTP4.
⁴ Nails shall be 16d box (0.1350x3 1/4") or 10d common (0.1480x3 1/4"). Screws shall be Simpson SDS25412 (1/4"x4 1/2" min).
⁵ Provide 3"x3"x0.229" plate washer at all anchor bolts. Anchor bolts shall be positioned such that plate edge of plate washer is with 1/2" of the edge of the bottom plate. (Plate washers may be diagonally slotted with a width of up to 13/16" and a length not to exceed 1 1/4")
⁶ Rows must be offset at least 1/2" and staggered.

Date:
5/27/20 Permit Sub
7/15/20 Early Com'ts
8/24/20 FND'N PERMIT
9/8/20 FND'N REVISION
10/30/20
Sub-2 2008-006

Scale:
Sheet:



VANEY / SHINDE
New Residence
4207 West Mercer Way
Mercer Island, WA 98040

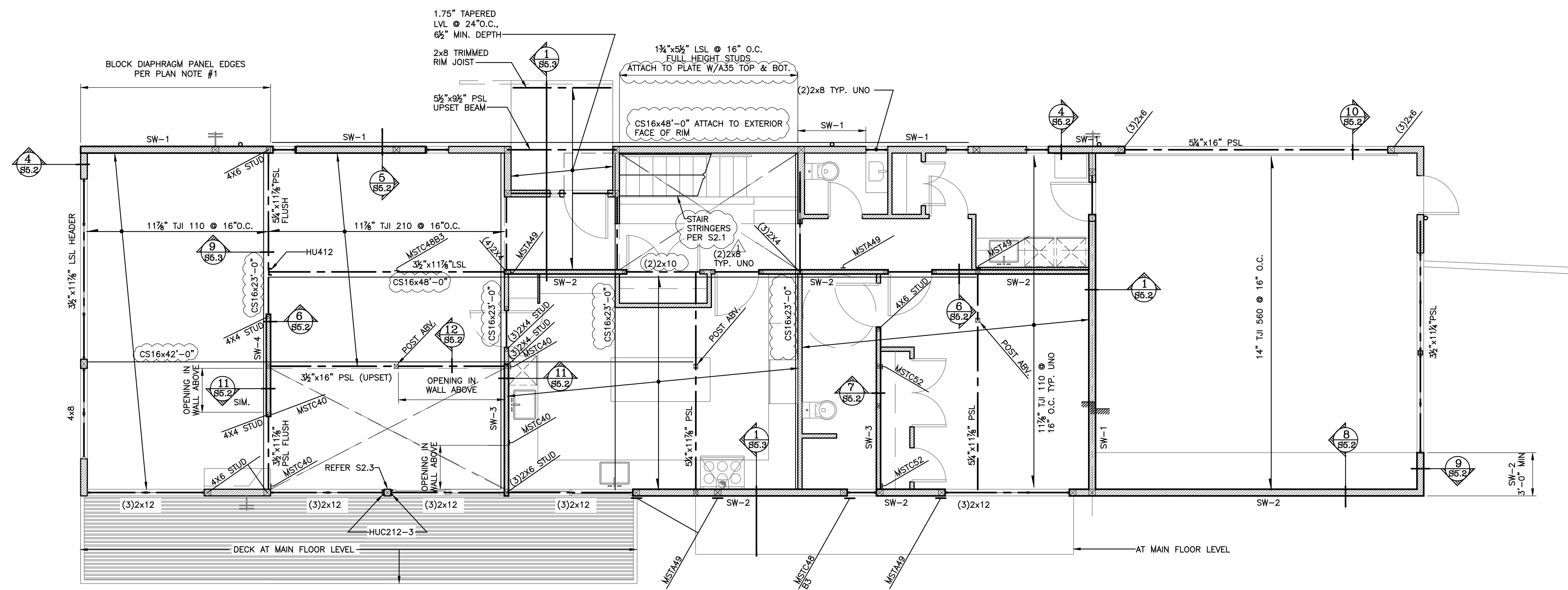

1 Upper Floor Framing
Scale: 1/4"=1'-0"

- FLOOR FRAMING PLAN NOTES**
- FLOOR SHEATHING SHALL BE 23/32" APA, STURD-I-FLOOR WITH A PANEL INDEX OF 40/20. NAIL TO FRAMING WITH 10D COMMON NAILS AT 6" OC AT PANEL EDGES AND 12" OC IN FIELD UNLESS NOTED OTHERWISE ON PLANS.
 - ALL HEADERS AND BEAMS SHALL BE (2) 2X8 MINIMUM, U.N.O. REFER TO NOTE 3 FOR SUPPORT REQUIREMENTS.
 - ALL COLUMNS SHALL BE DOUBLE STUD MINIMUM, U.N.O., WITH THE BEAM OR HEADER BEARING FULLY ON THE COLUMN. INDIVIDUAL STUDS SHALL BE NAILED TOGETHER PER THE GENERAL STRUCTURAL NOTES.
 - EXTERIOR WALL SHEATHING SHALL BE 15/32" APA RATED SHEATHING WITH A PANEL INDEX OF 24/0 (ORIENTED STRAND BOARD OF EQUIVALENT THICKNESS, EXPOSURE RATING, AND PANEL INDEX MAY BE USED IN LIEU OF PLYWOOD AT CONTRACTORS' OPTION).
 - ATTACH LVL PLIES W/ (2) SDS25600 @12"OC, ALTERNATE FACE.

Mark	Sheathing	Block/g	Panel Nailing	Attachment to top plate	Bottom Plate Attachment			Capacity (plf) (Seismic)
					Rim Joist Req'd	Nailing to wood below	A. Bolts to concrete below	
SW 1	15/32" APA Sheathing	Yes	8d @ 6"oc	CLIP @ 24"oc	2x or 1 1/4" LSL	16d @ 6"oc	5/8" @ 48"oc	240
SW 2	15/32" APA Sheathing	Yes	8d @ 4"oc	CLIP @ 20"oc	2x or 1 1/4" LSL	16d @ 4"oc	5/8" @ 48"oc	355
SW 3	15/32" APA Sheathing	Yes	8d @ 3"oc	CLIP @ 16"oc	2x or 1 1/4" LSL	16d @ 3"oc	5/8" @ 36"oc	455
SW 4	15/32" APA Sheathing	Yes	8d @ 2"oc	CLIP @ 12"oc	4x or 3 1/2" LSL	(2) Rows* 16d @ 5 1/4"oc	5/8" @ 24"oc	595

* Nails shall be 8d box. Nailing applies to all panel edges (block all unsupported panel edges), top & bottom plates and blocking. Nail to intermediate framing members w/ 8d @ 12"oc.
(Note: where stud spacing is 24"oc, nail to intermediate framing members with 8d@6"oc.)
* Framing at adjoining panel edges shall be 3-inch nominal or wider and nails shall be staggered.
* Clip shall be either A35, L174.
* Nails shall be 16d box (0.1350x3 1/4") or 10d common (0.1480x3 1/4")
Screws shall be Simpson SDS25412 (1/4"Øx4 1/2"min).
* Provide 3"x3"Ø.229" plate washer at all anchor bolts. Anchor bolts shall be positioned such that plate edge of plate washer is with 1/2" of the edge of the bottom plate.
(Plate washers may be diagonally slotted with a width of up to 13/16" and a length not to exceed 1 1/4")
* Rows must be offset at least 1/2" and staggered.

NOTE: SHEET S2.2 IS INCLUDED IN FOUNDATION PERMIT SET FOR REFERENCE ONLY.

Date:
5/27/20 Permit Sub
7/15/20 Early Comm. Is
8/24/20 FND'N PERMIT
9/8/20 FND'N REVISION
10/30/20
Sub-2 2006-006

Scale:
Sheet:

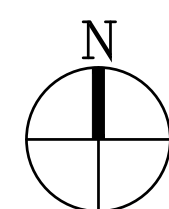
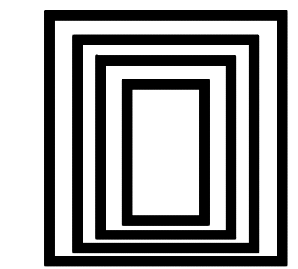

1 Clerestory Framing
scale: 1/4"=1'-0"

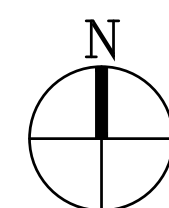
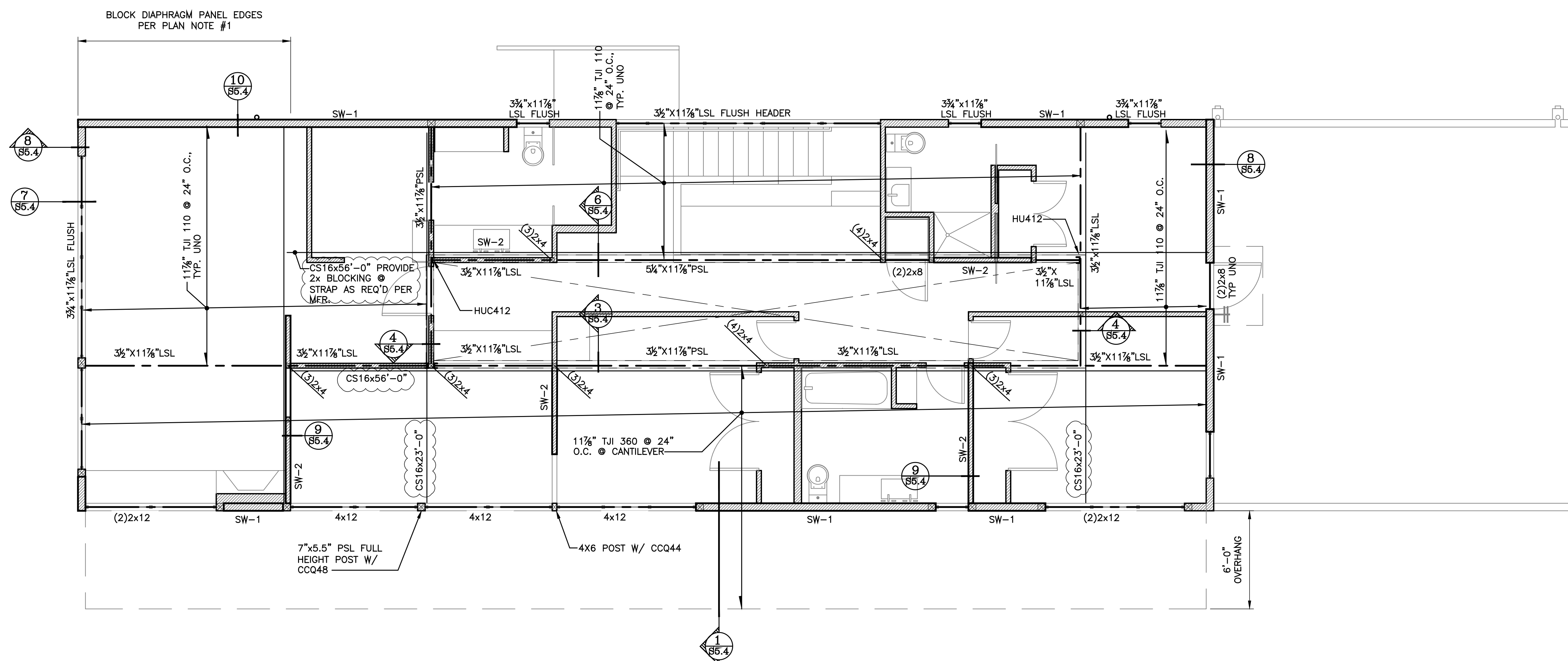
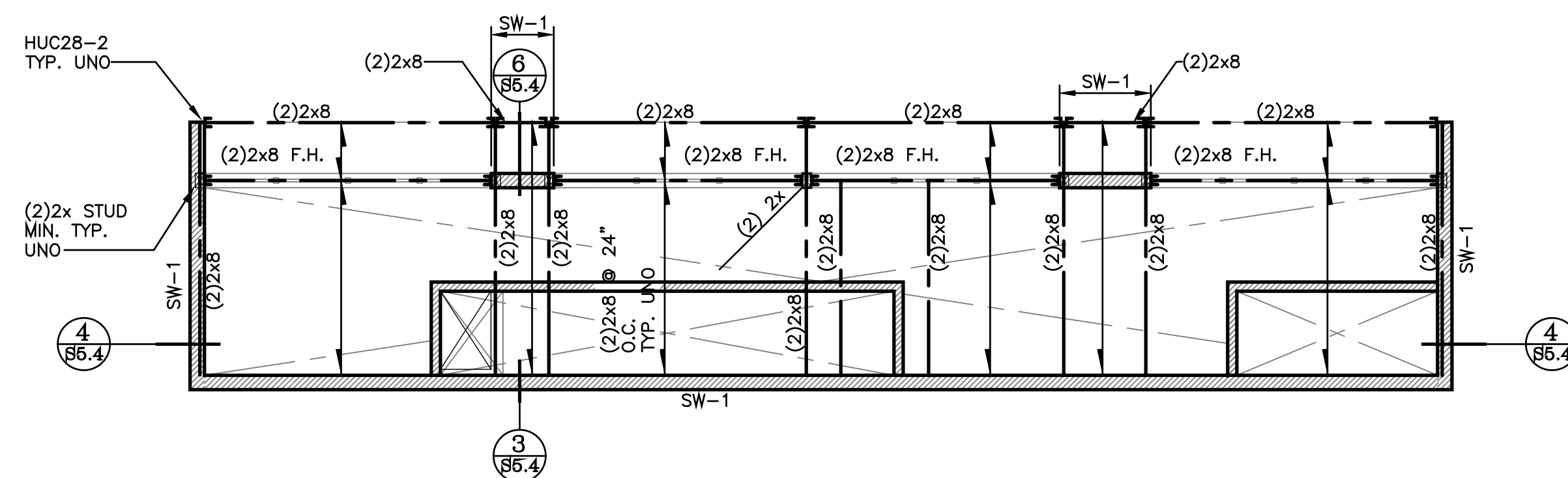

2 Roof Framing
scale: 1/4"=1'-0"

ROOF FRAMING PLAN NOTES

- ROOF SHEATHING SHALL BE 15/32" APA RATED SHEATHING WITH A PANEL INDEX OF 24/0. NAIL TO FRAMING WITH 8D COMMON NAILS AT 6" OC AT PANEL EDGES AND 12" OC IN FIELD UNLESS NOTED OTHERWISE ON PLANS. WHERE NOTED ON THE PLANS ALL PANEL EDGES SHALL BE BLOCK WITH MINIMUM 2X MATERIAL.
- ALL HEADERS AND BEAMS SHALL BE (2) 2X8 MINIMUM, U.N.O. REFER TO NOTE 3 FOR SUPPORT REQUIREMENTS.
- ALL COLUMNS SHALL BE DOUBLE STUD MINIMUM, U.N.O., WITH THE BEAM OR HEADER BEARING FULLY ON THE COLUMN. INDIVIDUAL STUDS SHALL BE NAILED TOGETHER PER THE GENERAL STRUCTURAL NOTES.
- EXTERIOR WALL SHEATHING SHALL BE 15/32" APA RATED SHEATHING WITH A PANEL INDEX OF 24/0 (ORIENTED STRAND BOARD OF EQUIVALENT THICKNESS, EXPOSURE RATING, AND PANEL INDEX MAY BE USED IN LIEU OF PLYWOOD AT CONTRACTORS' OPTION).
- ATTACH LVL PLIES W/ (2) SDS25600 @16"OC, ALTERNATE FACE.

Mark	Sheathing	Blck'g	Panel Nailing	Attachment to top plate	Bottom Plate Attachment			Capacity (pF) (Seismic)
					Rim Joist Req'd	Nailing to wood below	A. Bolts to concrete below	
SW 1	15/32" APA Sheathing	Yes	8d @ 6"oc	CLIP @ 24"oc	2x or 1 1/2" LSL	16d @ 6"oc	5/8" @ 48"oc	240
SW 2	15/32" APA Sheathing	Yes	8d @ 4"oc	CLIP @ 20"oc	2x or 1 1/2" LSL	16d @ 4"oc	5/8" @ 48"oc	355
SW 3	15/32" APA Sheathing	Yes	8d @ 3"oc	CLIP @ 16"oc	2x or 1 1/2" LSL	16d @ 3"oc	5/8" @ 36"oc	455
SW 4	15/32" APA Sheathing	Yes	8d @ 2"oc	CLIP @ 12"oc	4x or 3 1/2" LSL	(2) Rows* 16d @ 5"oc	5/8" @ 24"oc	595

* Nails shall be 8d box. Nailing applies to all panel edges (block all unsupported panel edges), top & bottom plates and blocking. Nail to intermediate framing members w/ 8d @ 12"oc. (Note: where stud spacing is 24"oc, nail to intermediate framing members with 8d@6"oc.)
 * Framing at adjoining panel edges shall be 3-inch nominal or wider and nails shall be staggered.
 * Clip shall be either A35, LTH4.
 * Nails shall be 16d box (0.1350x3") or 10d common (0.1480x3").
 * Screws shall be Simpson SDS25412 (1/4"x4 1/2"min).
 * Provide 3"x3"x0.229" plate washer at all anchor bolts. Anchor bolts shall be positioned such that plate edge of plate washer is with 1/2" of the edge of the bottom plate.
 * (Plate washers may be diagonally slotted with a width of up to 13/16" and a length not to exceed 1 1/4")
 * Rows must be offset at least 1/2" and staggered.

Date:
5/27/20 Permit Sub
7/15/20 Early Comnt's
8/24/20 FND N PERMIT
9/8/20 FND N REVISION
10/30/20
Sub-2 2006-006

Scale:

Sheet:

Roof
Framing
S2.3

VANEY / SHINDE
New Residence
4207 West Mercer Way
Mercer Island, WA 98040

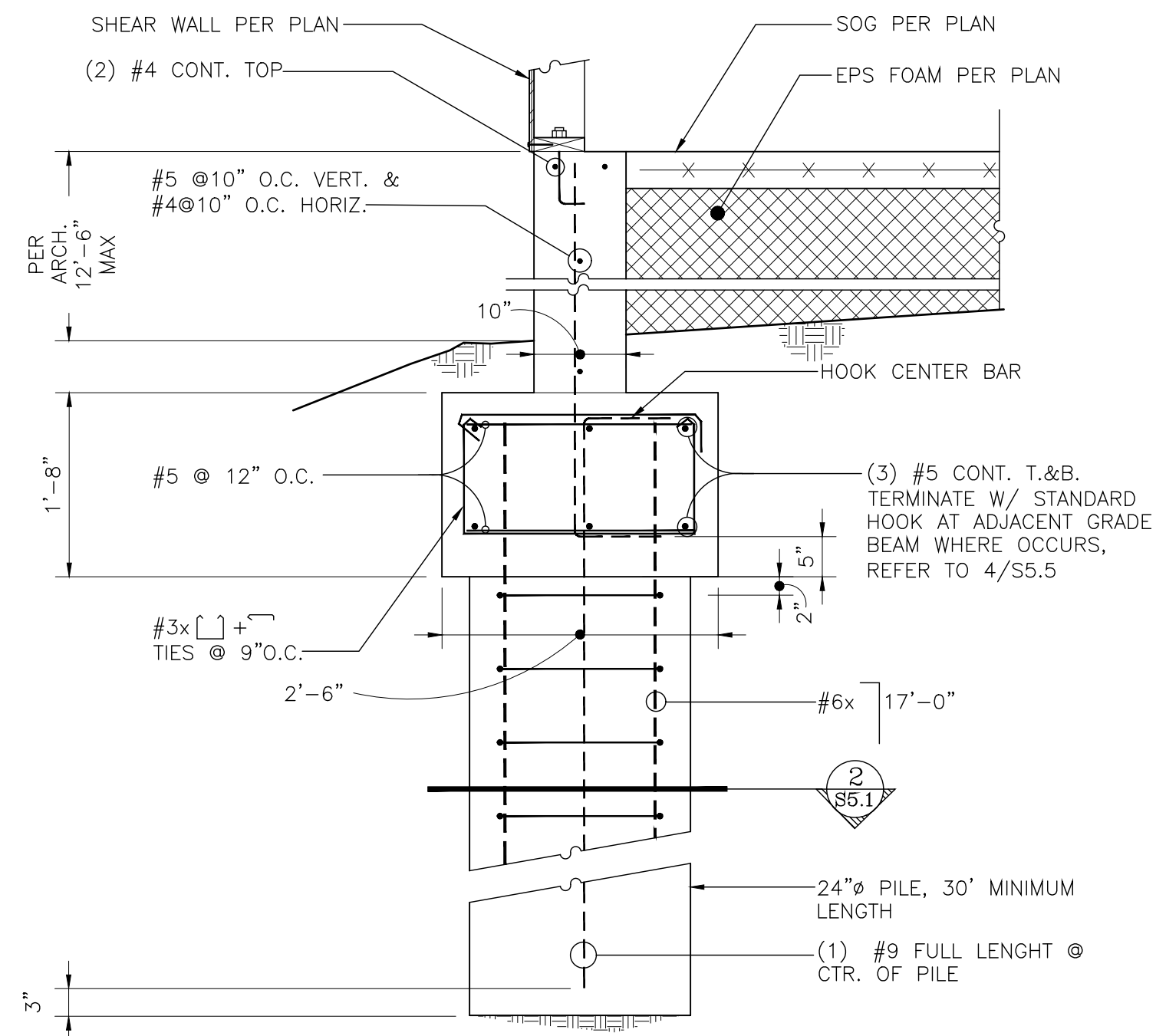

1 Section
scale: 3/4"=1'-0"

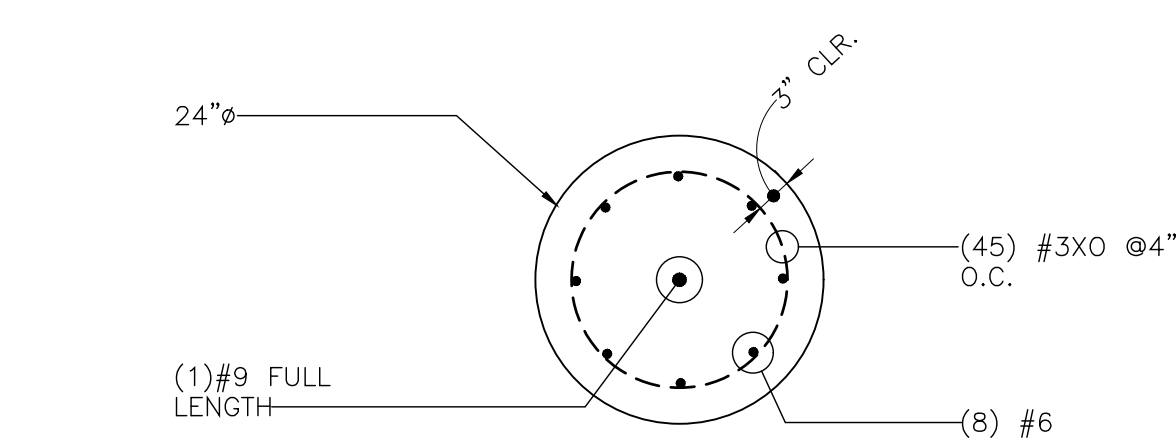

2 Section
scale: 3/4"=1'-0"

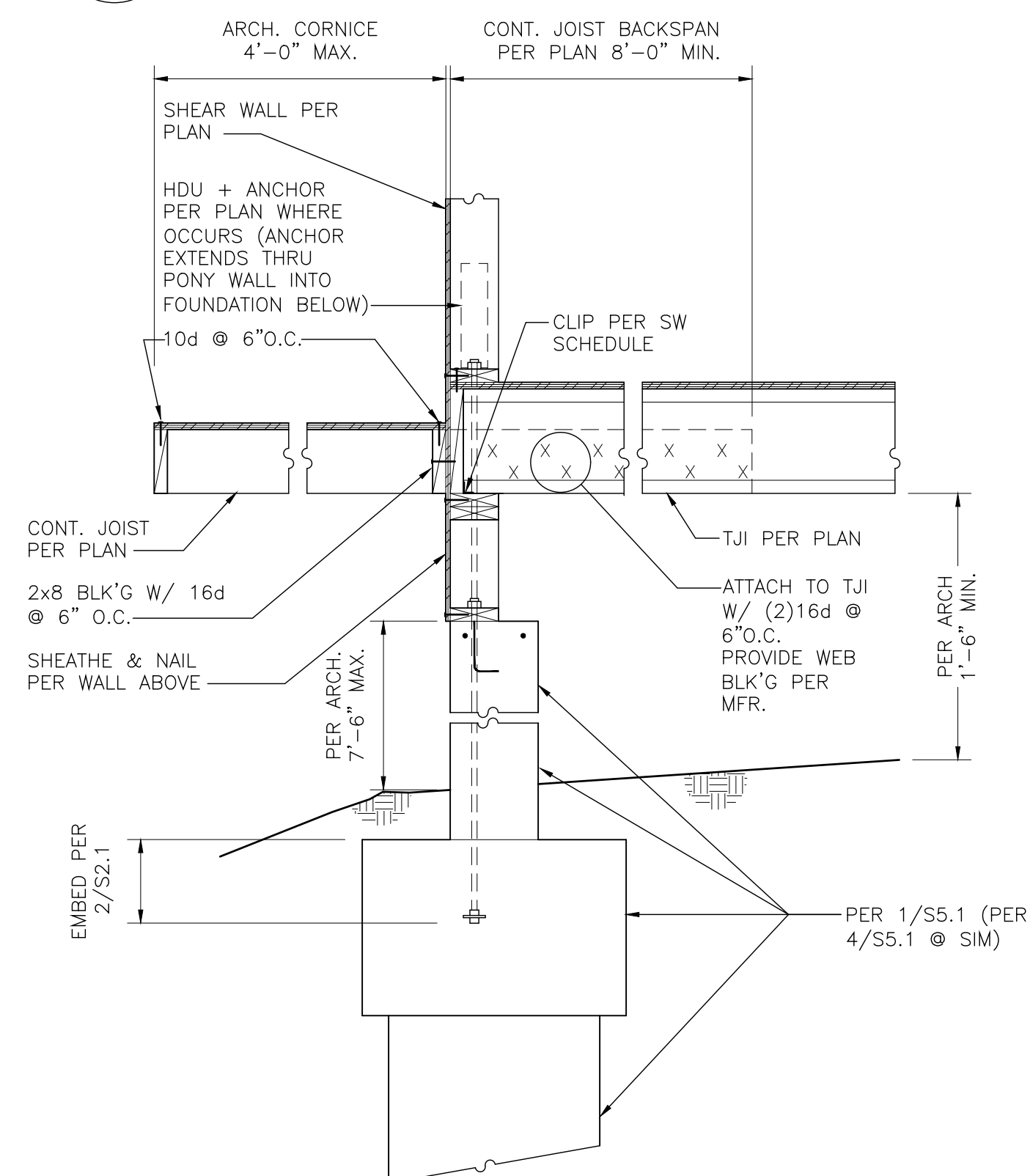

3 Section at Step
scale: 3/4"=1'-0"

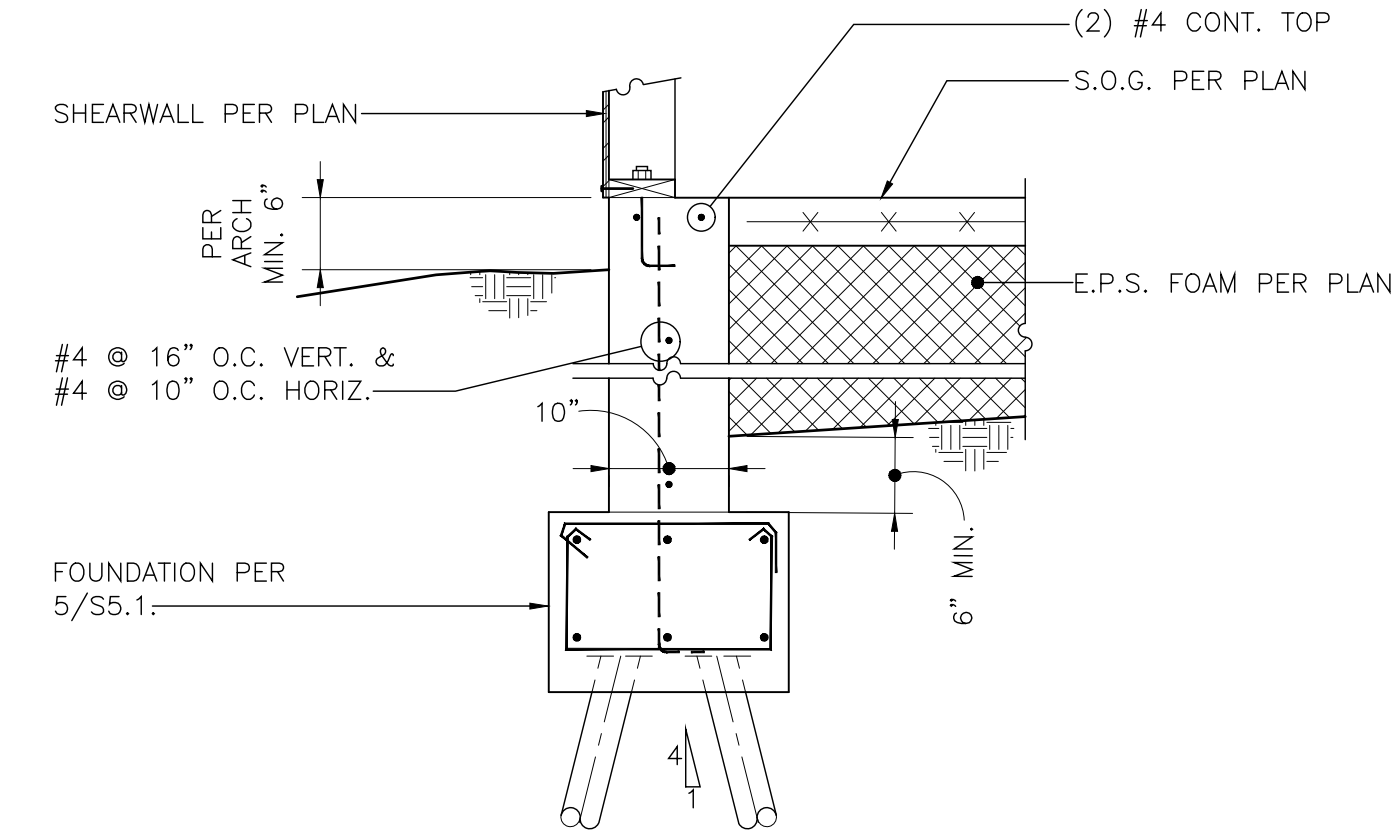

4 Section
scale: 3/4"=1'-0"

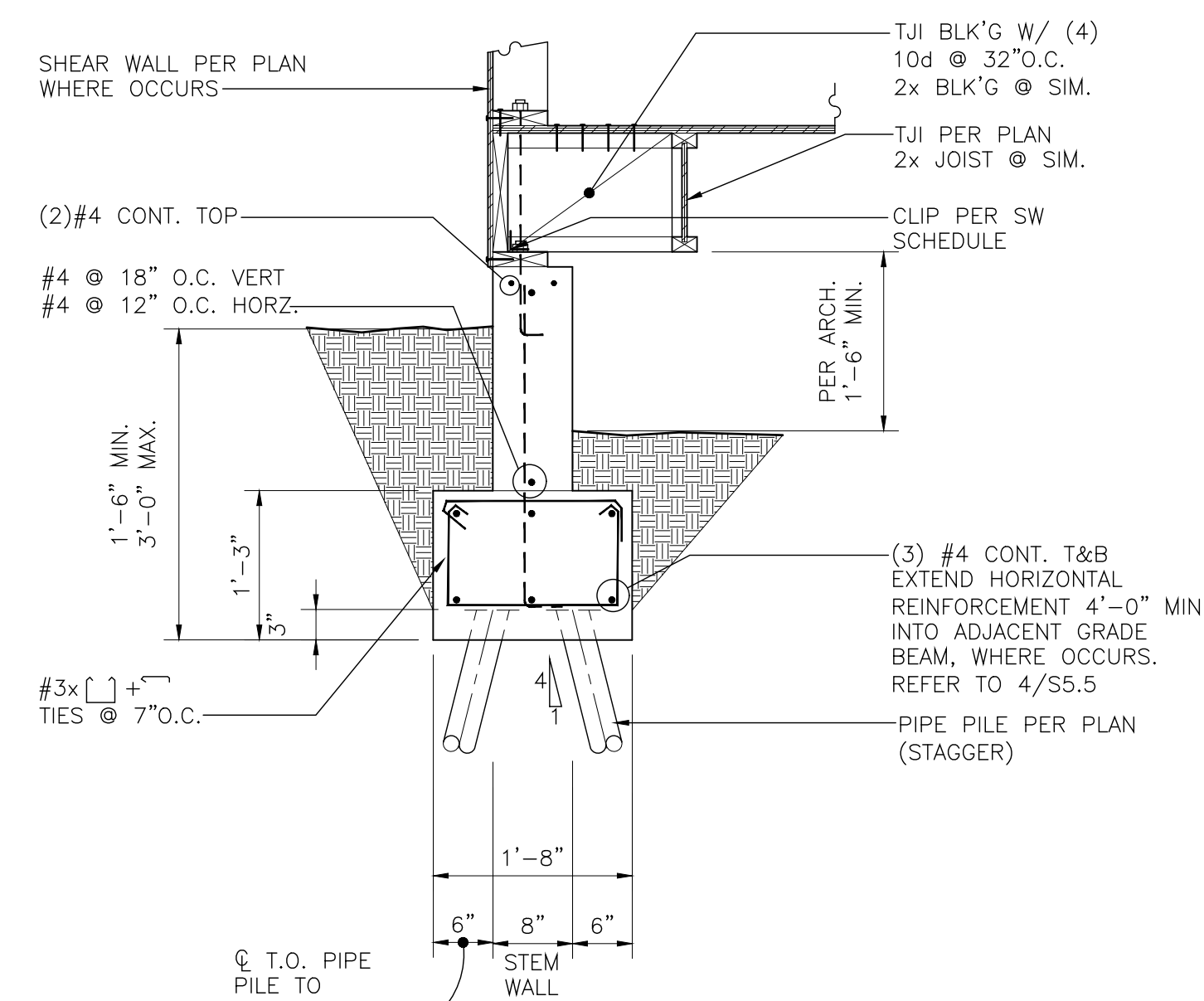

5 Section
scale: 3/4"=1'-0"

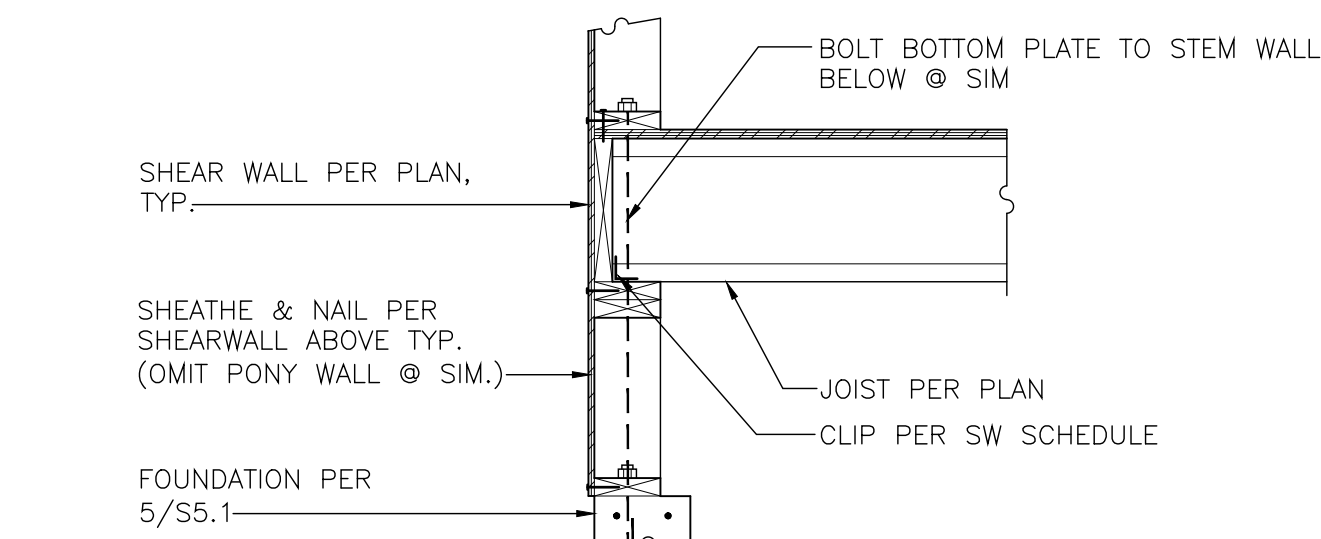

6 Section
scale: 3/4"=1'-0"

7 Section
Section

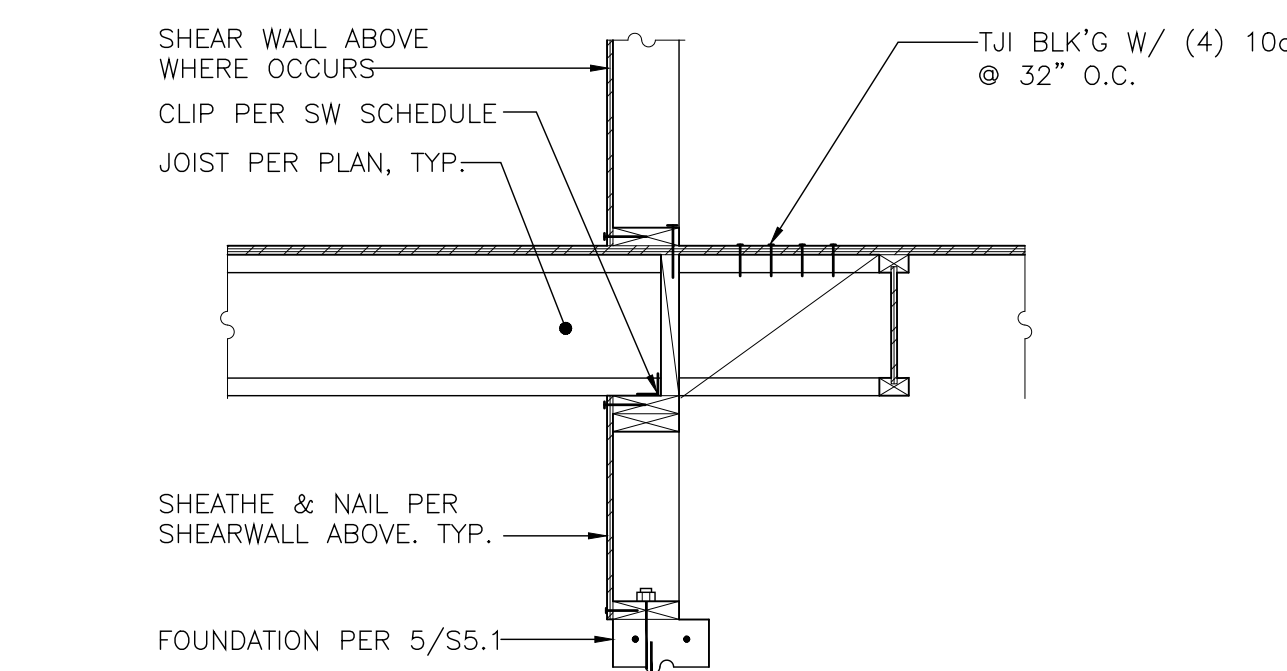

8 Section
scale: 3/4"=1'-0"

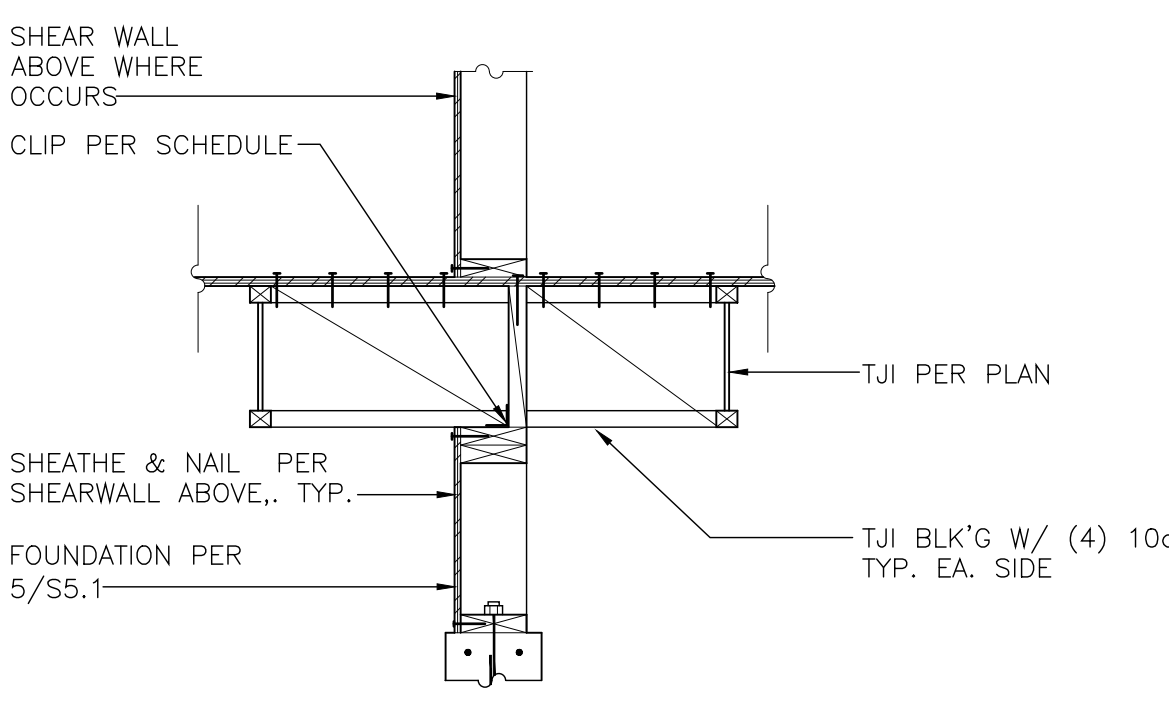

9 Section
scale: 3/4"=1'-0"

10 Section
scale: 3/4"=1'-0"

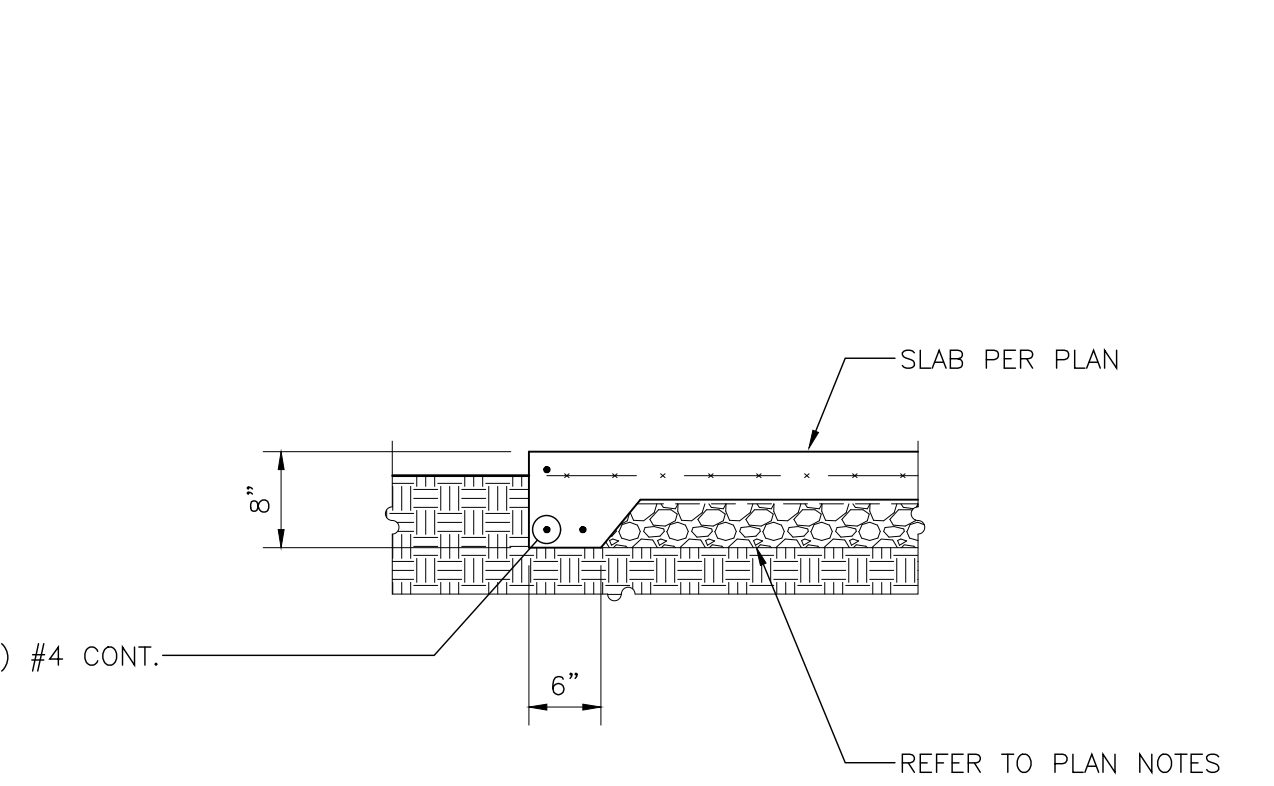

11 Typical Slab Edge
scale: 3/4"=1'-0"

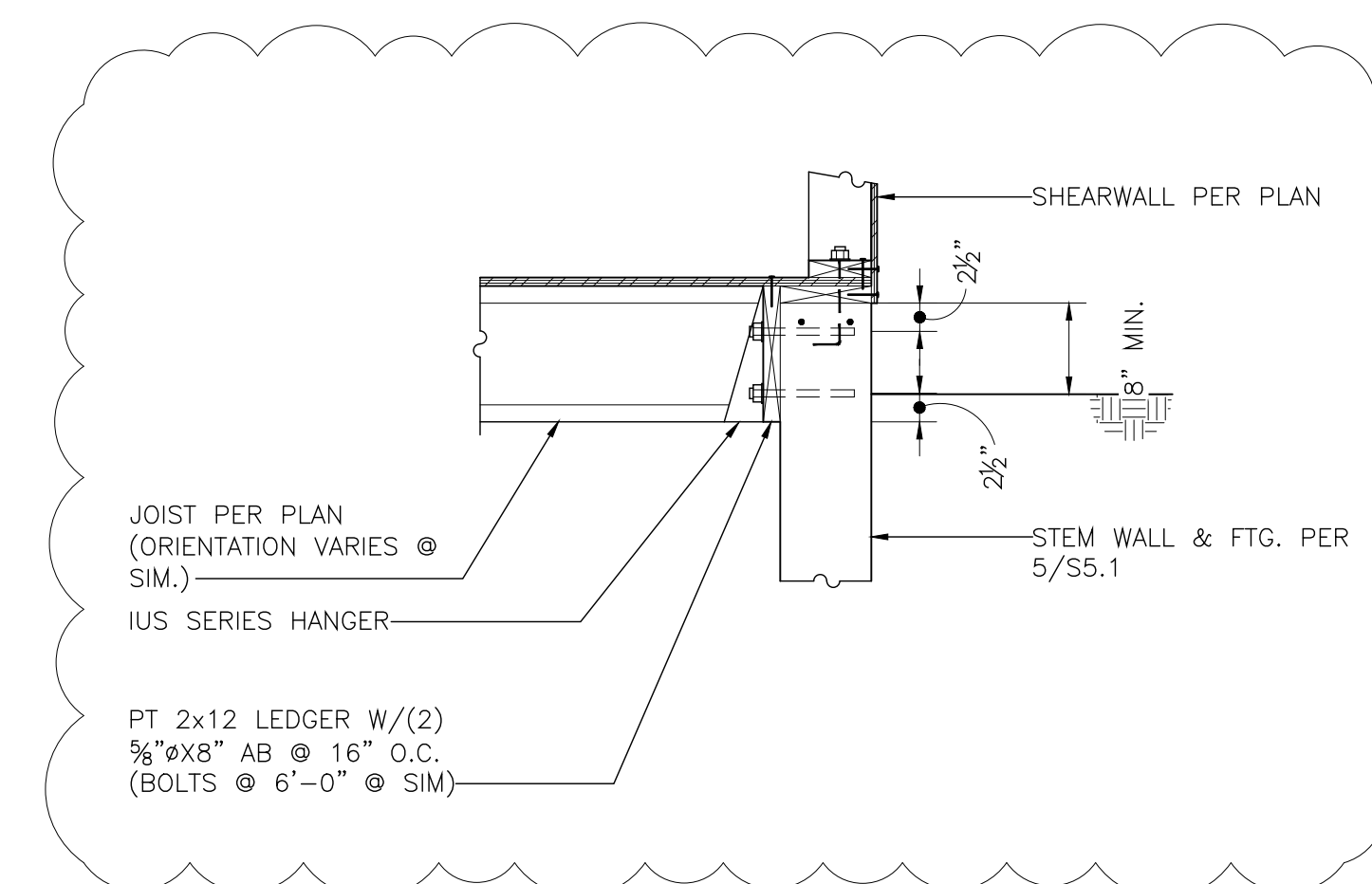

12 Dtl. @ North Elev. Ledger
scale: 3/4"=1'-0"



Date:
5/27/20 Permit Sub
7/15/20 Early Comnts
8/24/20 FND'N PERMIT
9/8/20 FND'N REVISION
10/30/20
Sub-2 2006-006

Scale:
Structural Details
S5.1

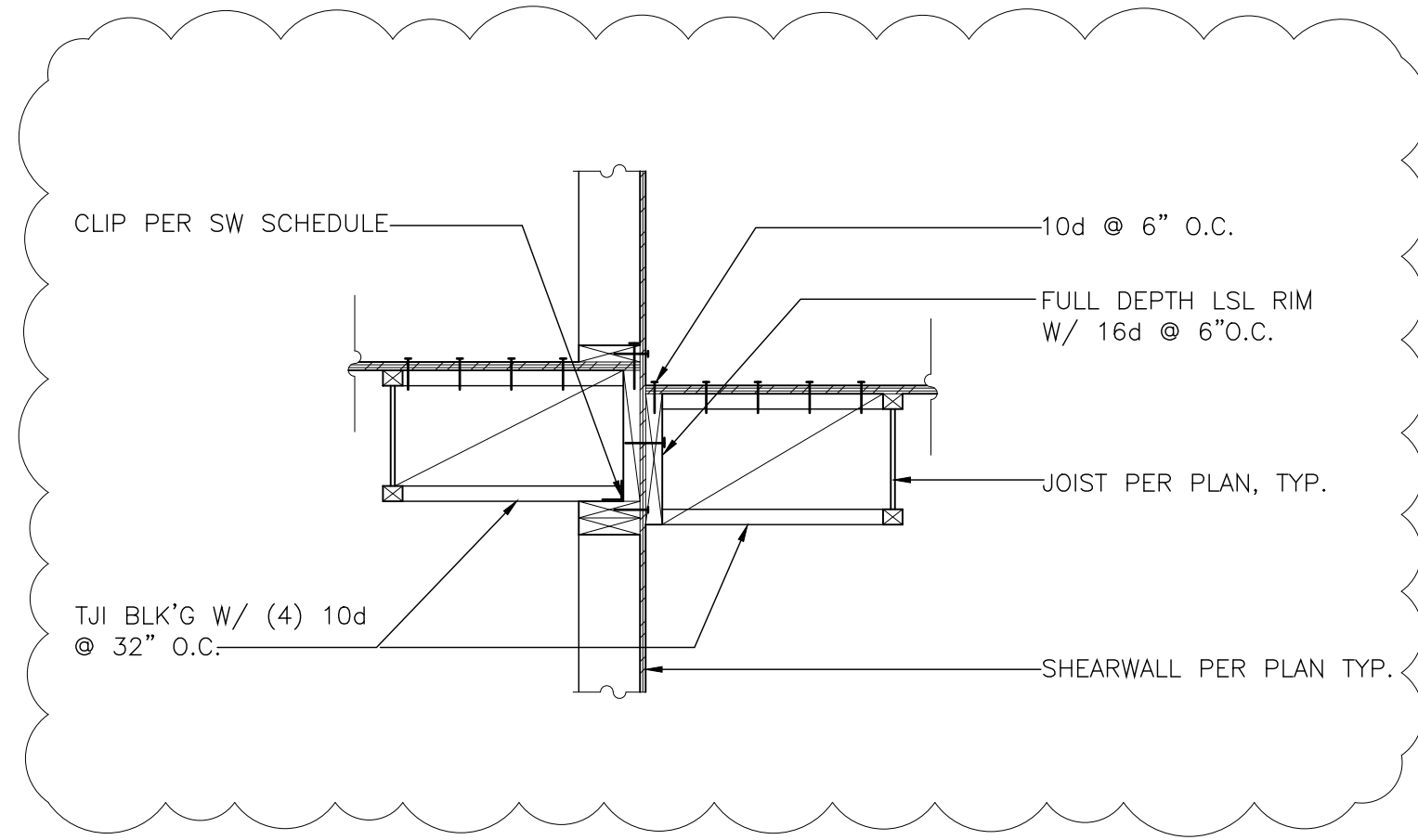

1 Dtl. @ Garage Roof Step
scale: 3/4"=1'-0"

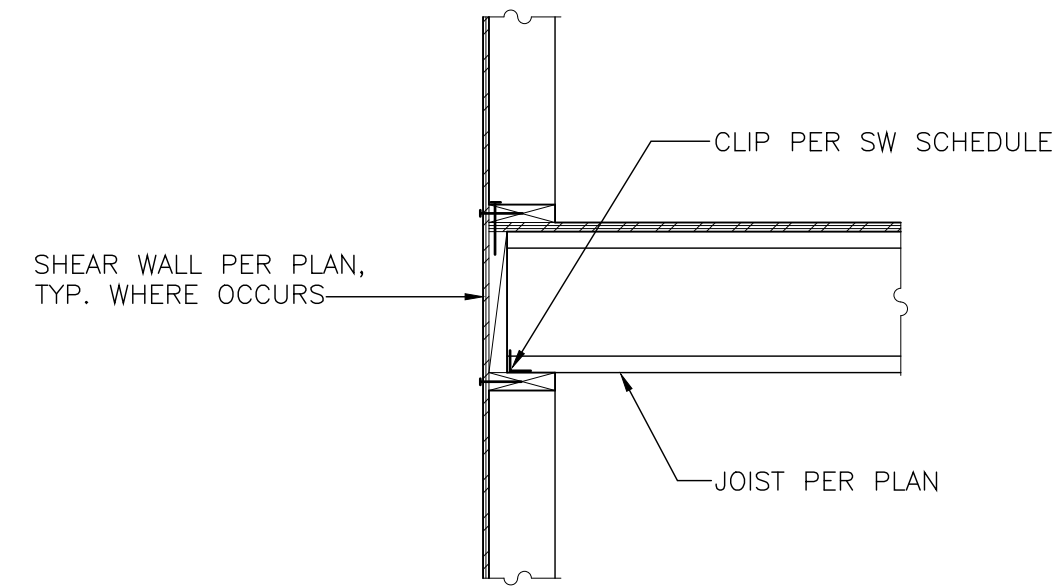

4 Section
scale: 3/4"=1'-0"

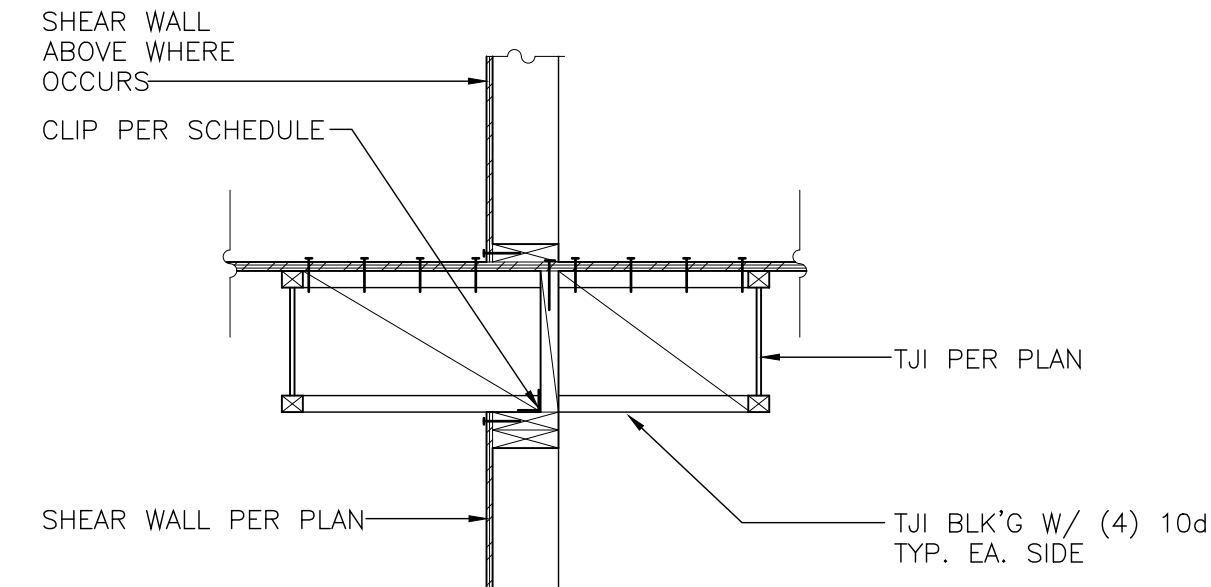

7 Section
Section

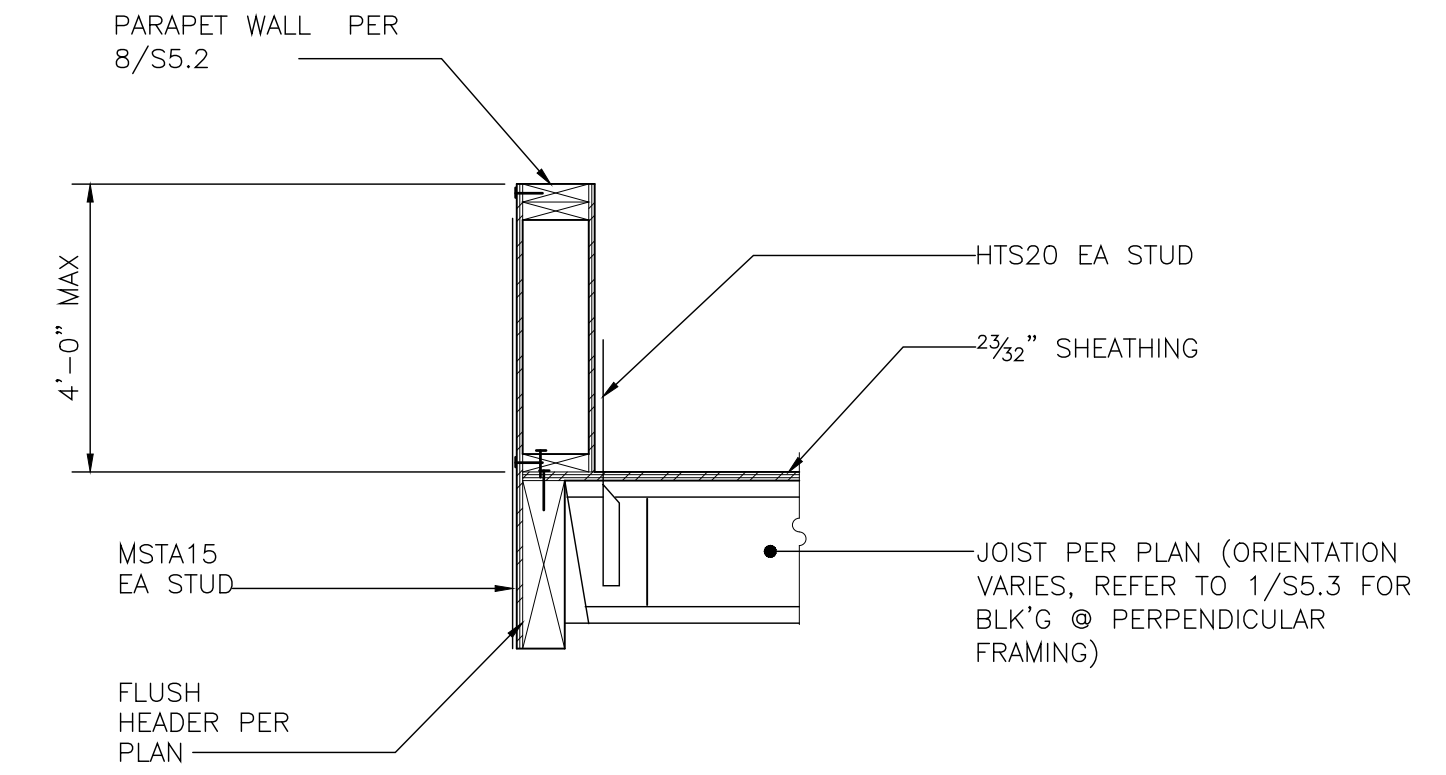

10
scale: 3/4"=1'-0"

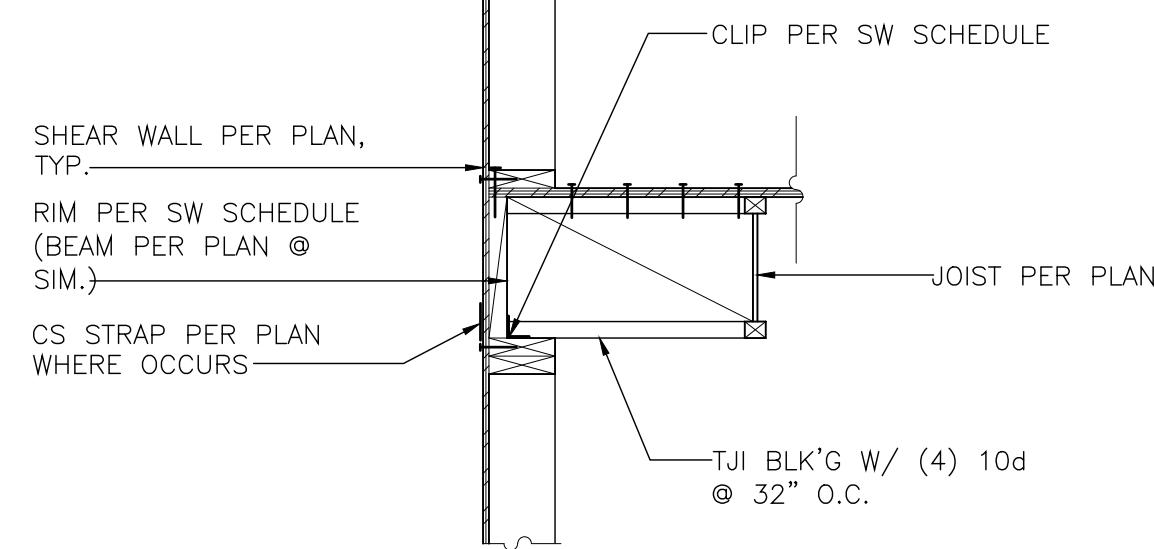

5 Section
scale: 3/4"=1'-0"

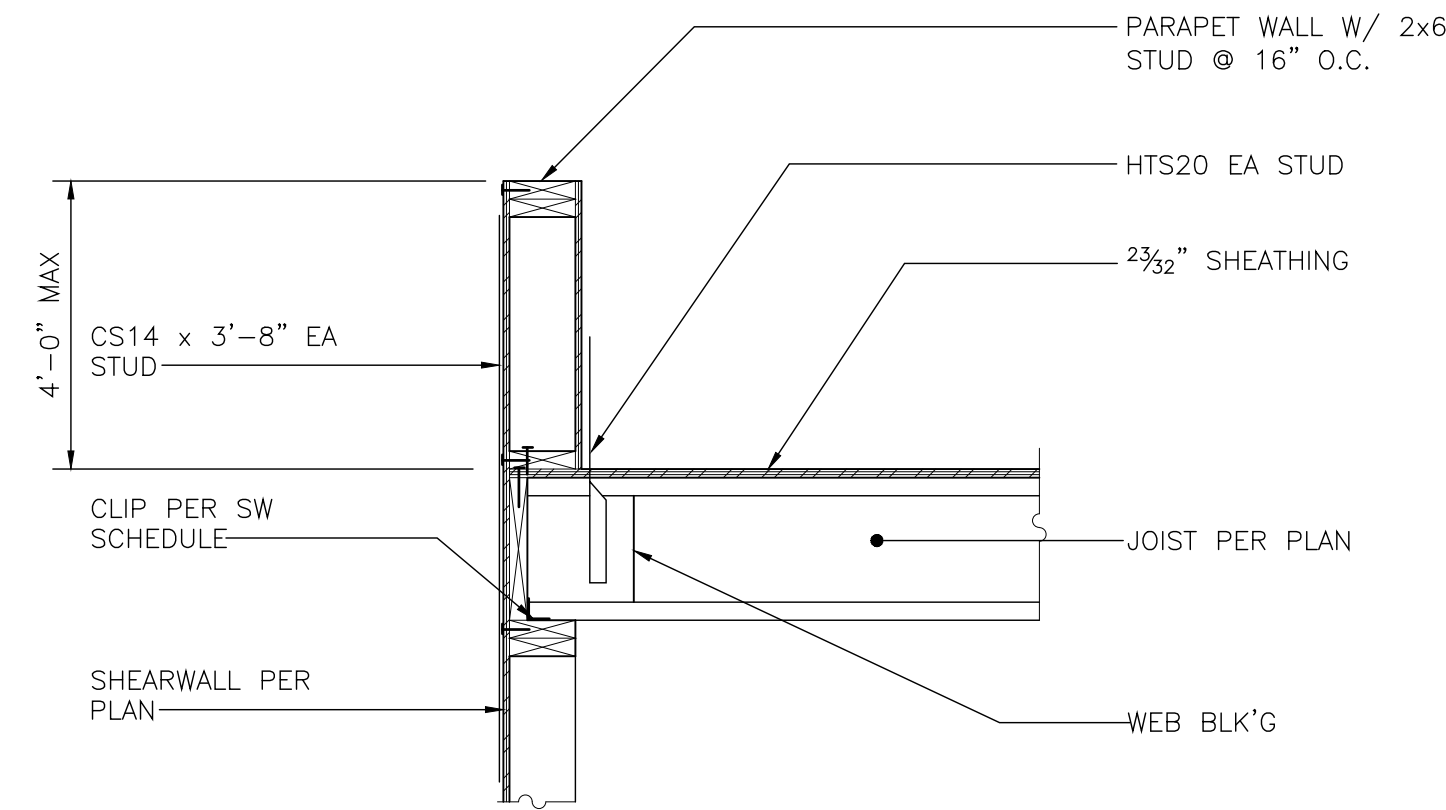

8 Section
scale: 3/4"=1'-0"

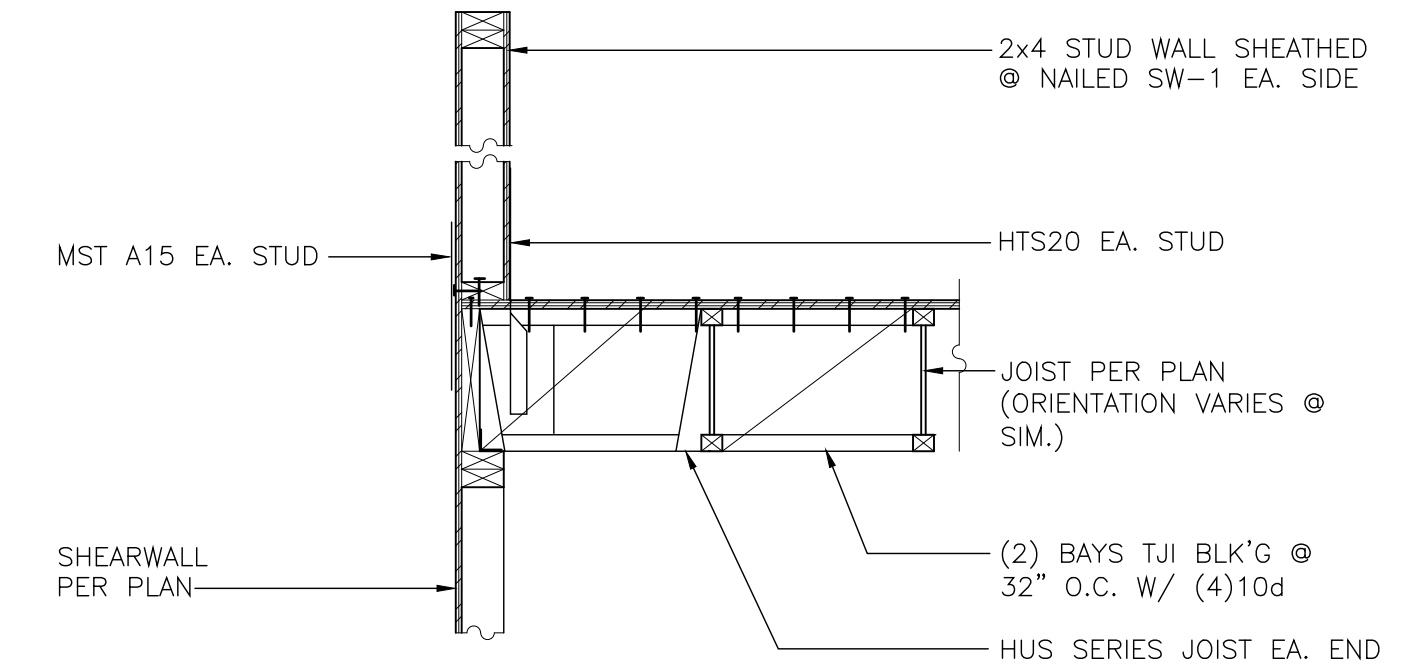

11 Section
scale: 3/4"=1'-0"

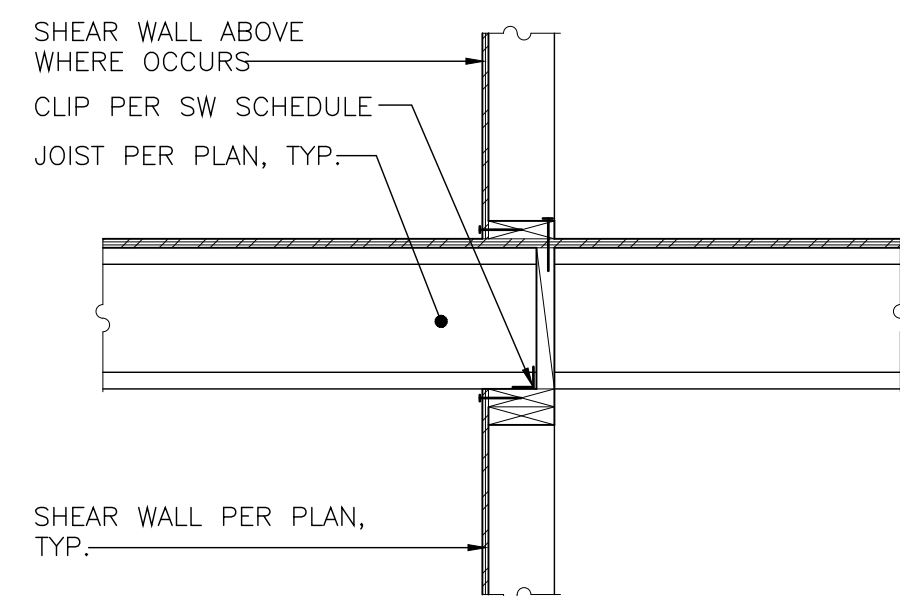

6 Section
scale: 3/4"=1'-0"

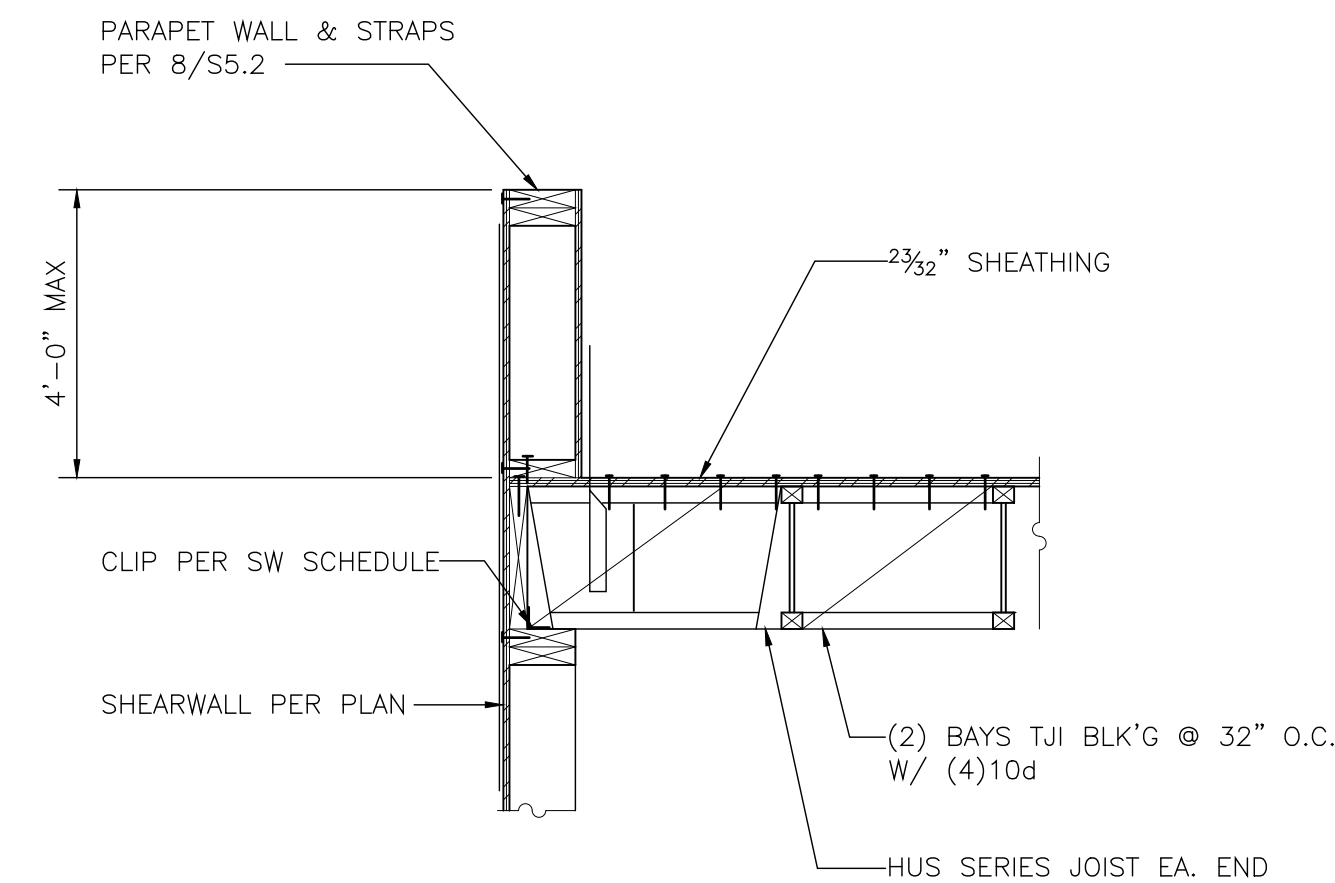

9 Section
scale: 3/4"=1'-0"

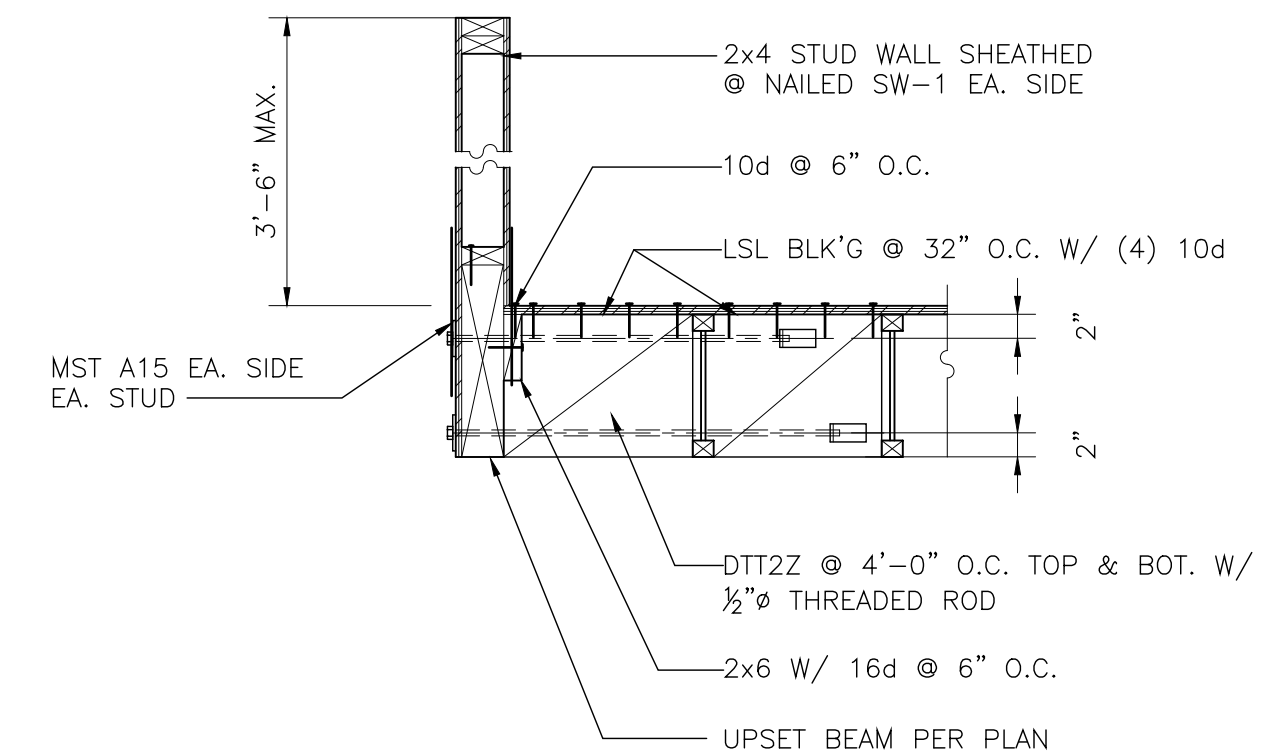

12
scale: 3/4"=1'-0"

2 Not Used
scale: 3/4"=1'-0"

3 Not Used
scale: 3/4"=1'-0"

NOTE: SHEET S5.2 IS INCLUDED IN FOUNDATION PERMIT SET FOR REFERENCE ONLY.

Date:
5/27/20 Permit Sub
7/15/20 Early Comm Is
8/24/20 FND'N PERMIT
9/8/20 FND'N REVISION
10/30/20
Sub-2 2006-006

Scale:
Sheet:

Structural
Details
S5.2

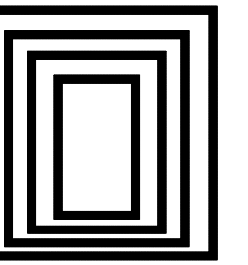

VANEY / SHINDE
New Residence
4207 West Mercer Way
Mercer Island, WA 98040

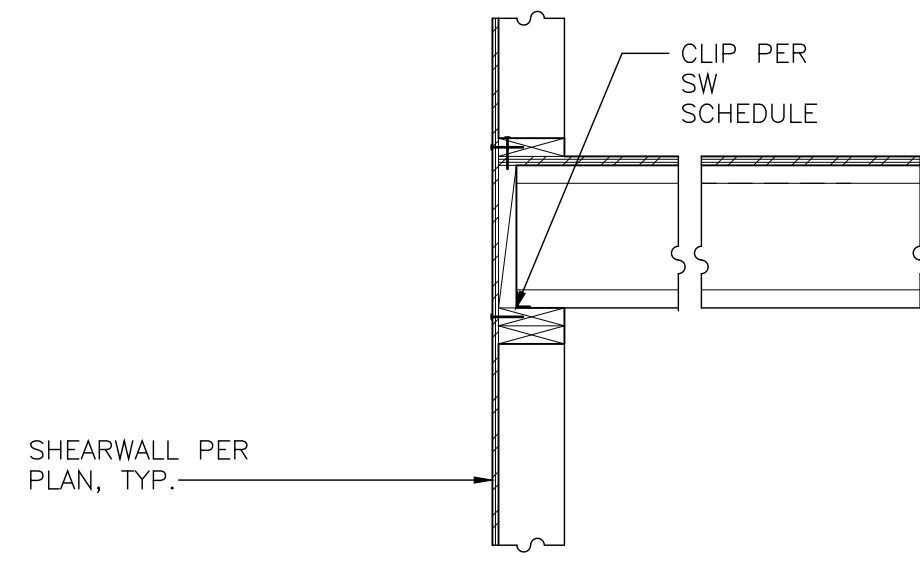

1 Section
scale: 3/4"=1'-0"

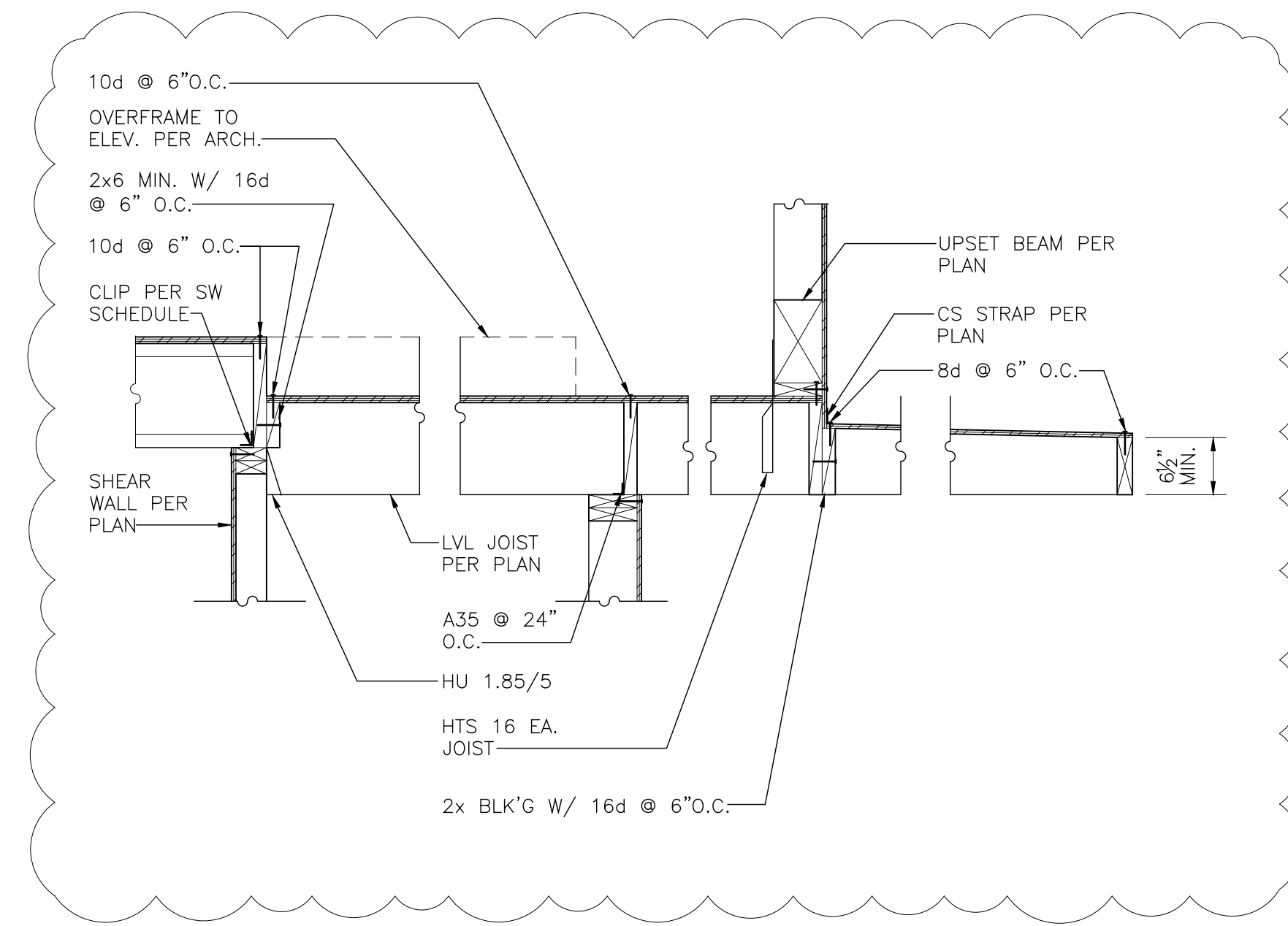

7 Entry Canopy
Scale: 3/4"=1'-0"

10 NOT USED
scale: 3/4"=1'-0"

4 NOT USED
scale: 3/4"=1'-0"

5 NOT USED
scale: 3/4"=1'-0"

2 NOT USED
scale: 3/4"=1'-0"

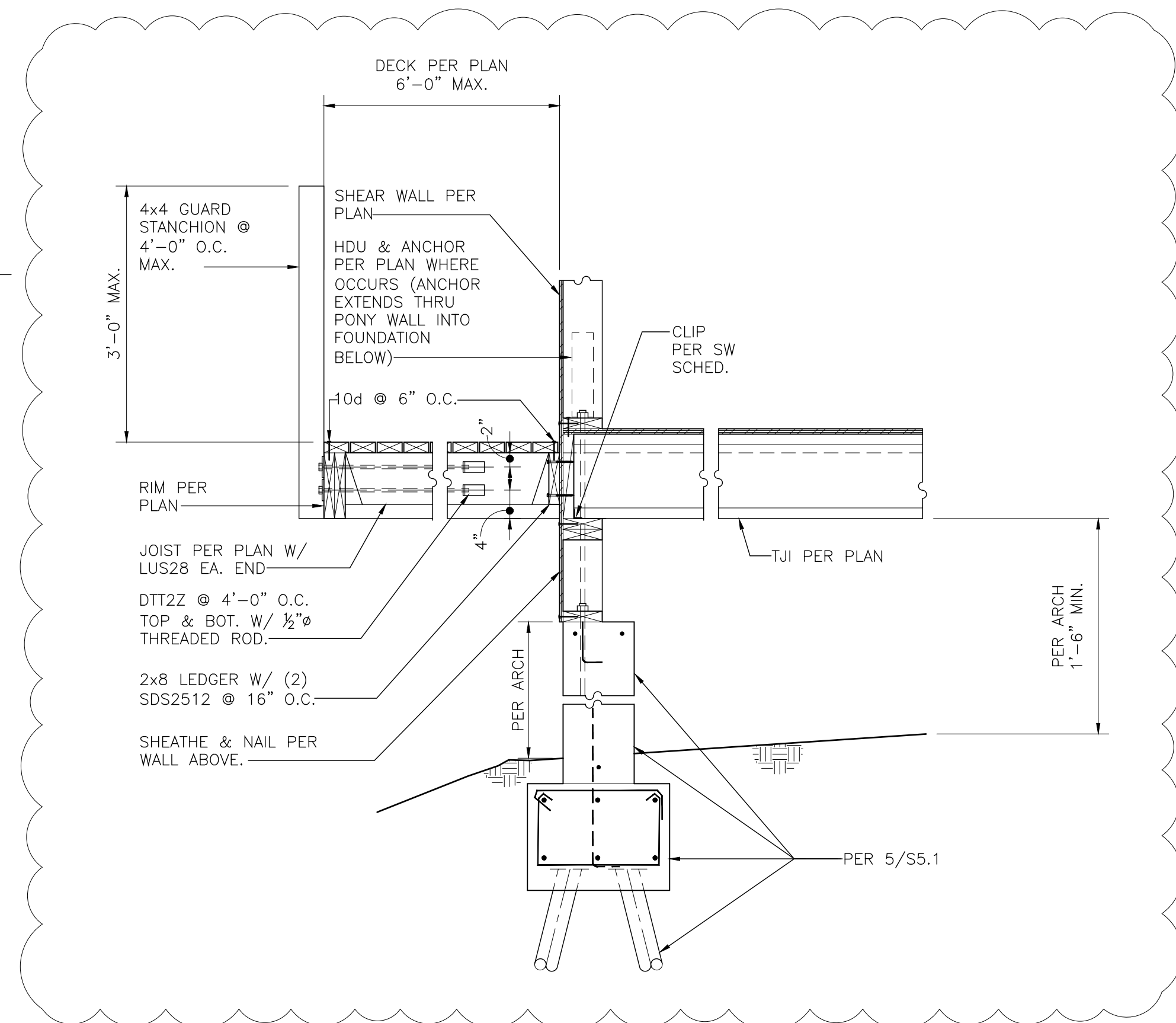

6 Section
scale: 3/4"=1'-0"

8 NOT USED
scale: 3/4"=1'-0"

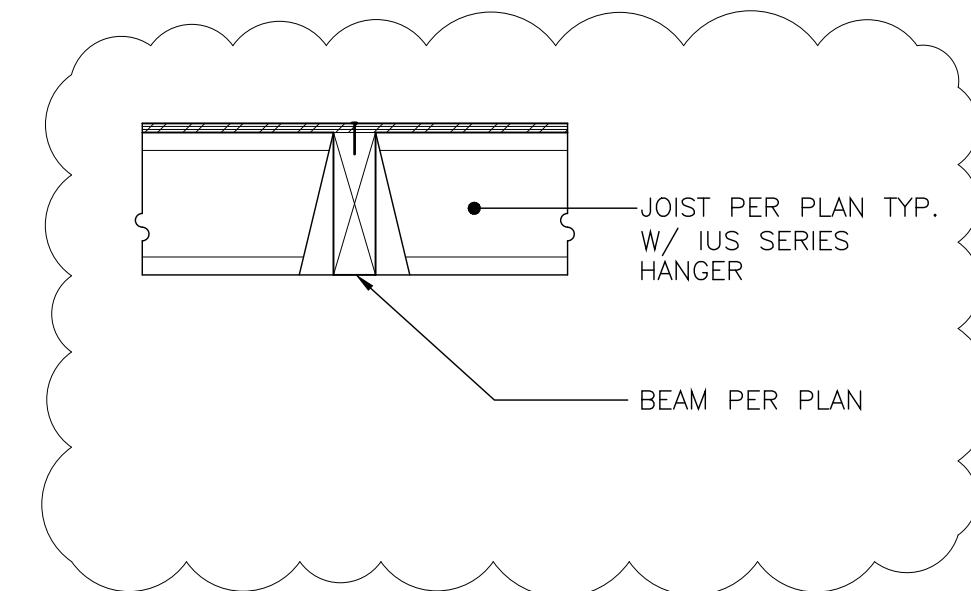

9 Flush Beam Dtl.
scale: 3/4"=1'-0"

11 NOT USED
scale: 3/4"=1'-0"

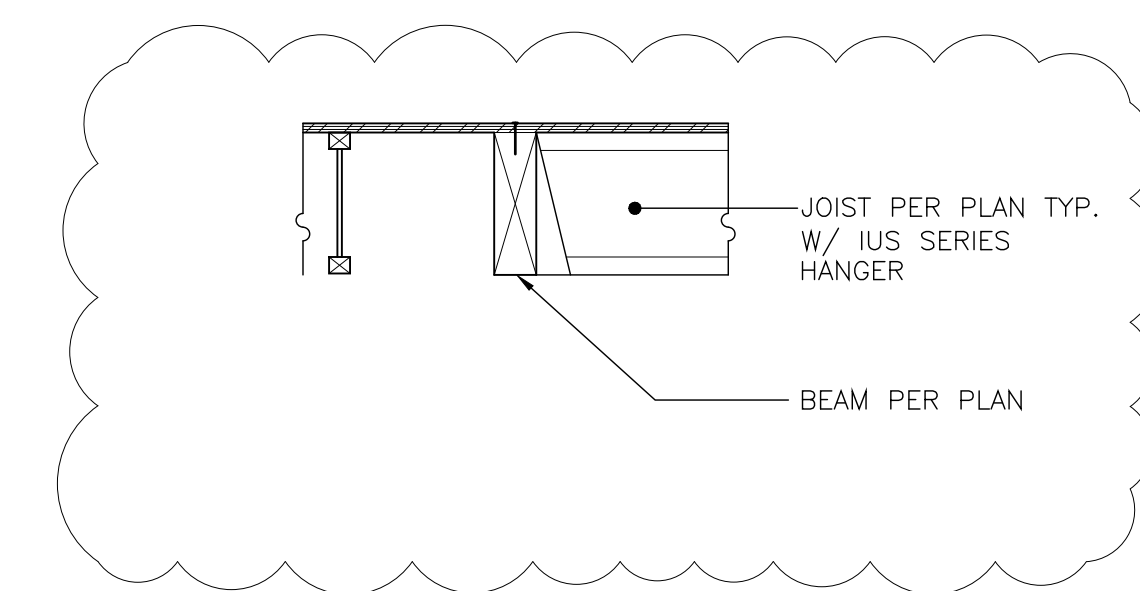

12 Flush Beam Dtl.
scale: 3/4"=1'-0"

3 NOT USED
scale: 3/4"=1'-0"



VANEY / SHINDE
New Residence
4207 West Mercer Way
Mercer Island, WA 98040

NOTE: SHEET S5.3 IS INCLUDED IN FOUNDATION PERMIT SET FOR REFERENCE ONLY.

Date:
5/27/20 Permit Sub
7/15/20 Early Comm Is
8/24/20 FND'N PERMIT
9/8/20 FND'N REVISION
10/30/20
Sub-2 2006-006

Scale:
Sheet:

Structural Details
S5.3

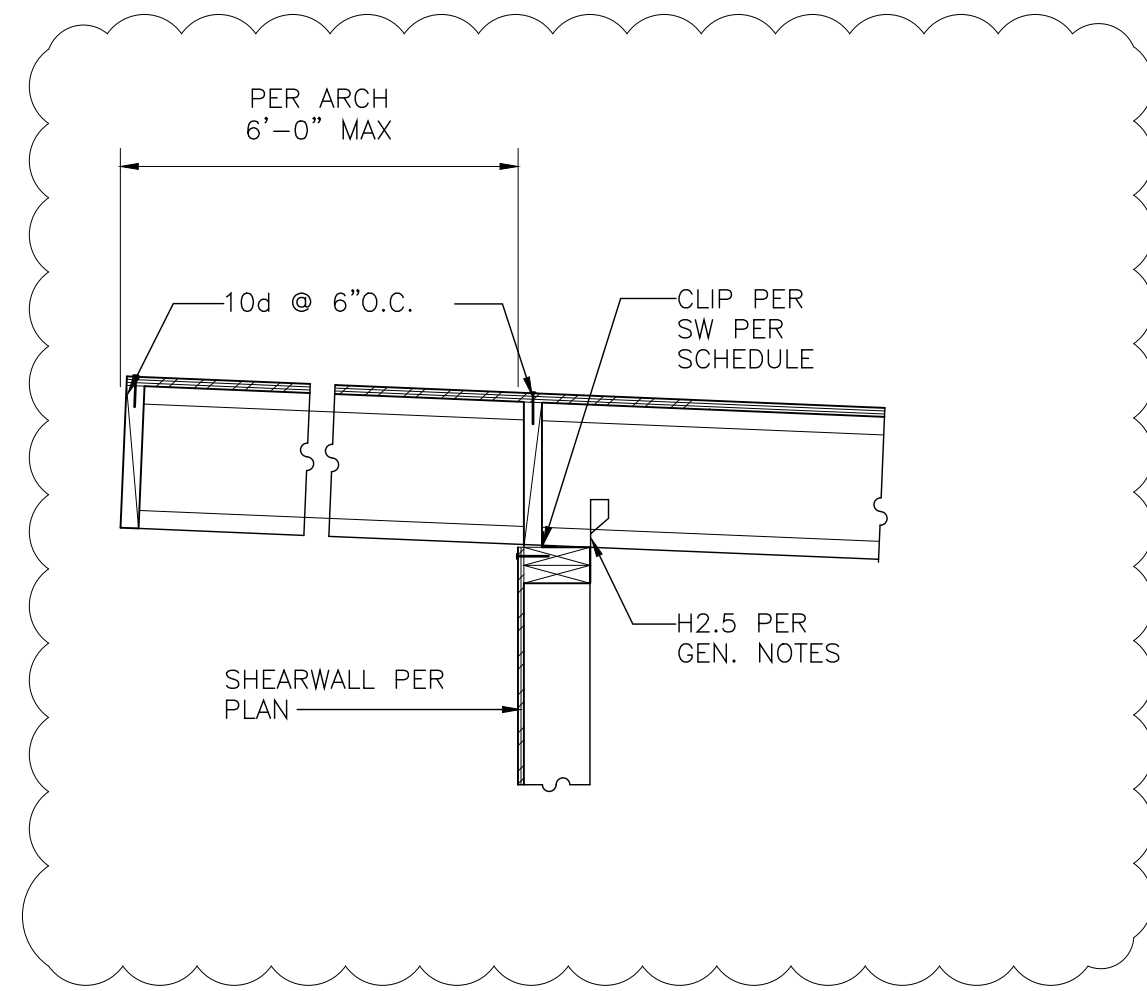

1 Section
scale: 3/4"=1'-0"

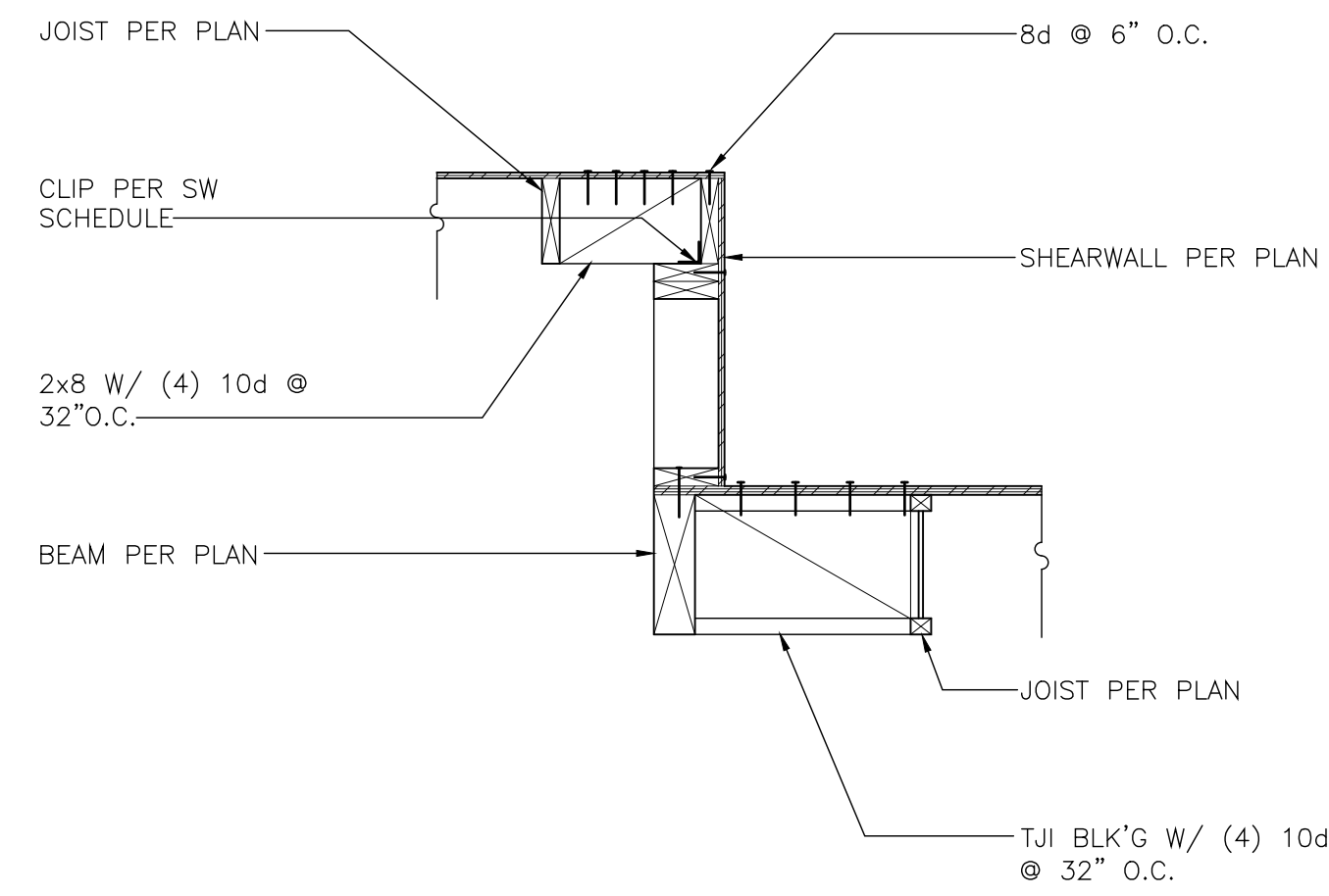

4 Section
scale: 3/4"=1'-0"

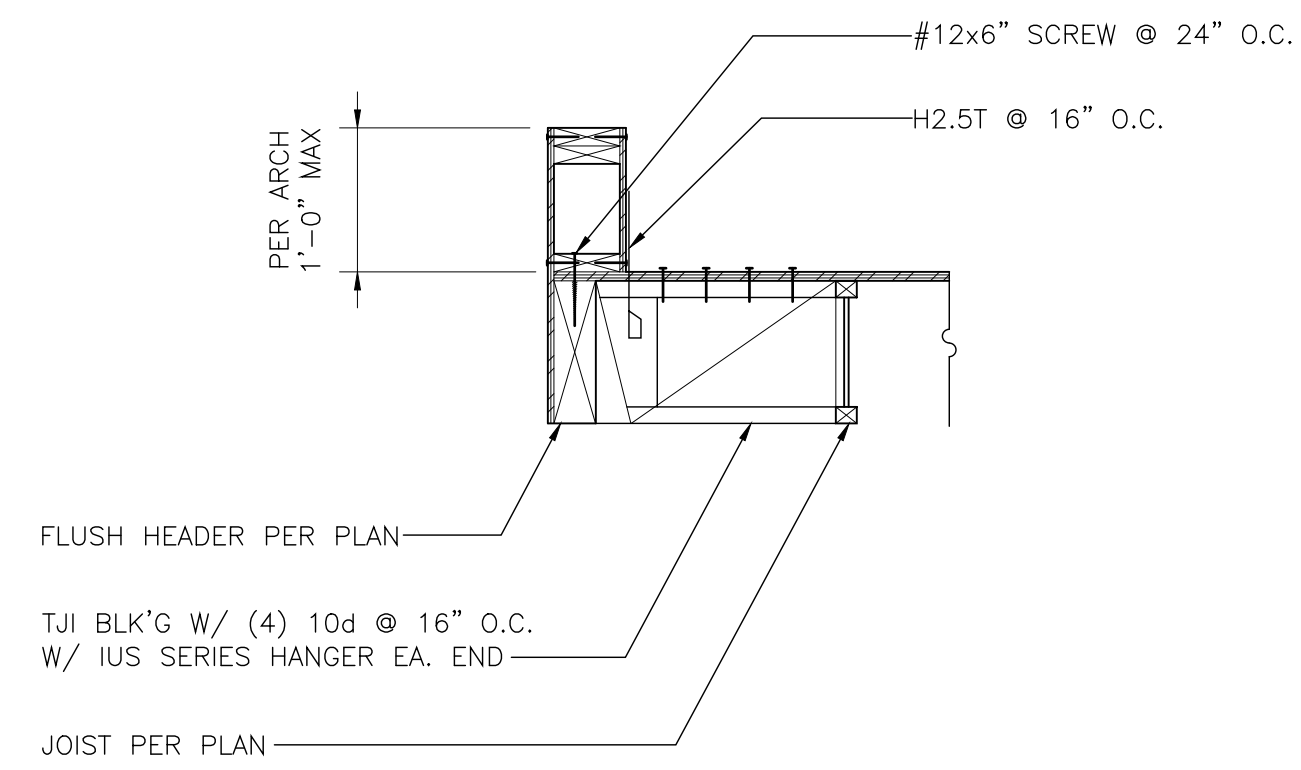

7 Section
Section

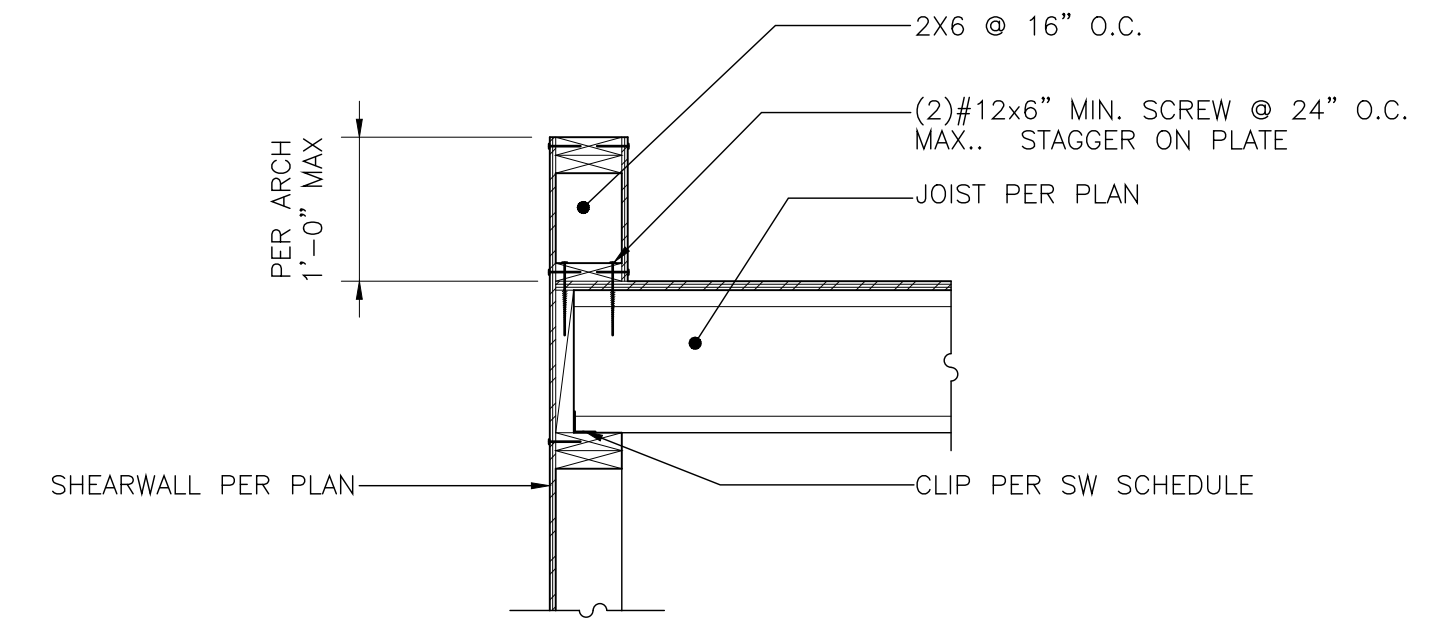

10 Section
scale: 3/4"=1'-0"

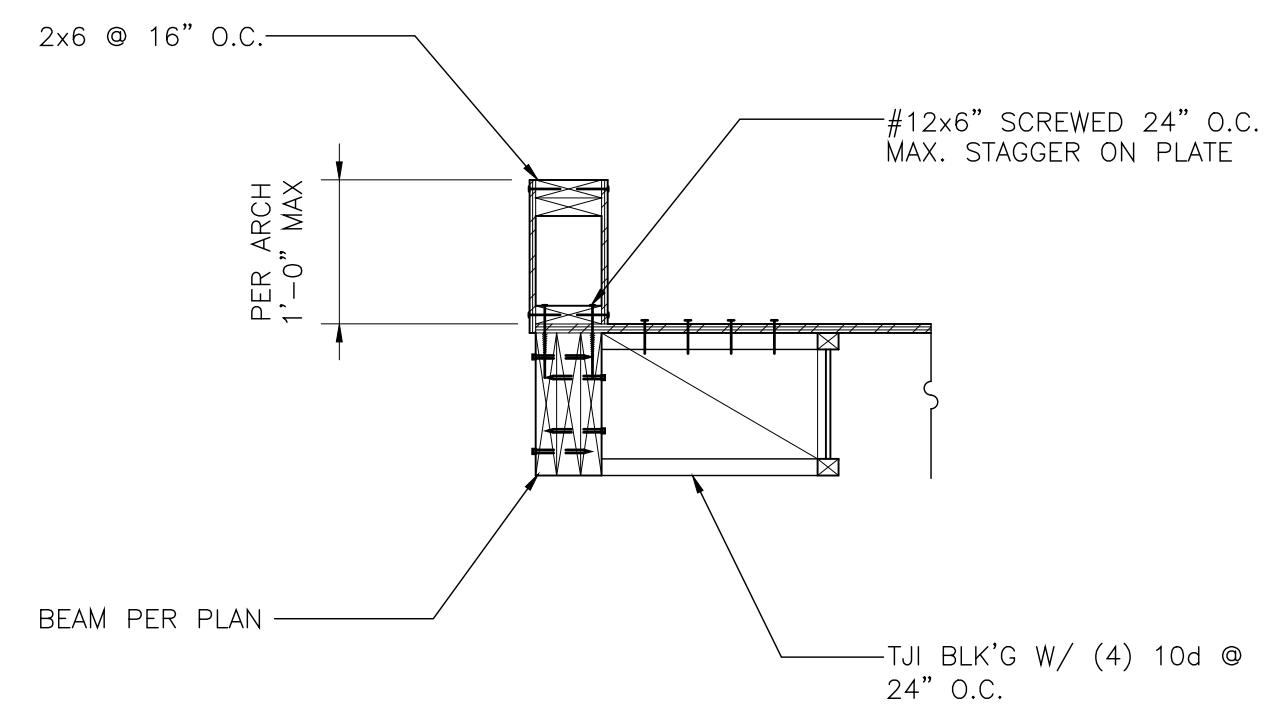

5 Section
scale: 3/4"=1'-0"

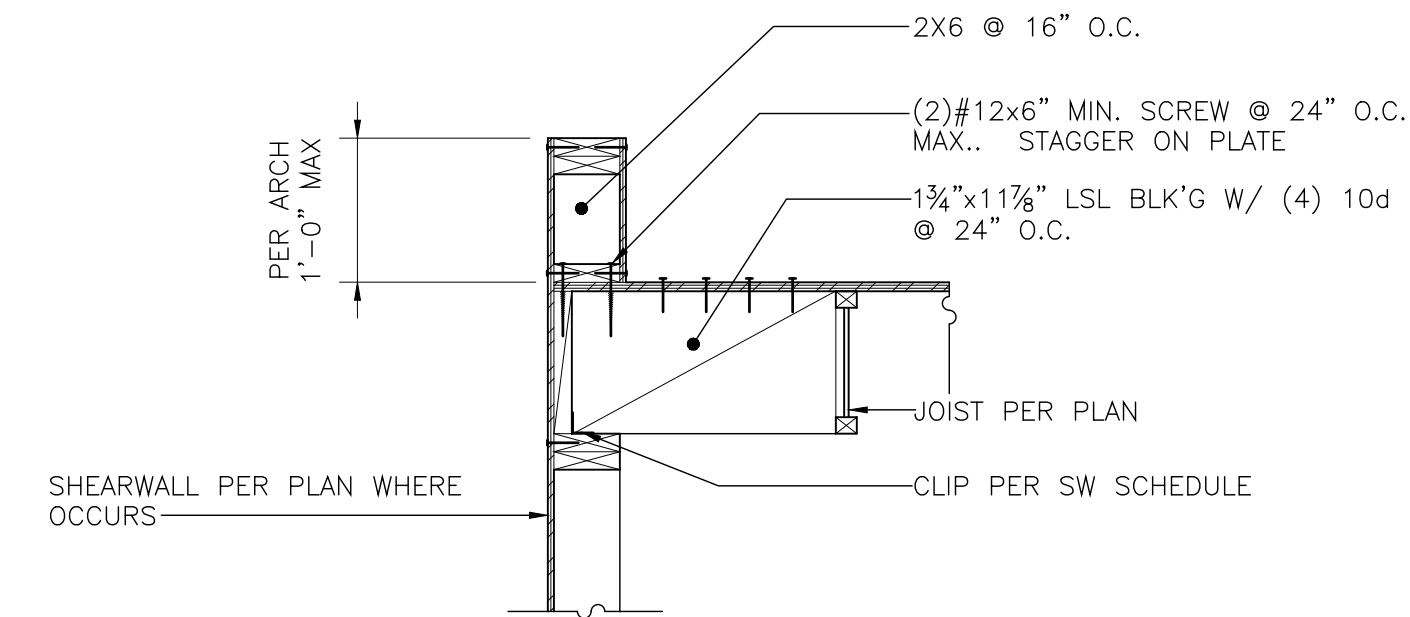

8 Section
scale: 3/4"=1'-0"

2 NOT USED
scale: 3/4"=1'-0"

11 NOT USED
scale: 3/4"=1'-0"

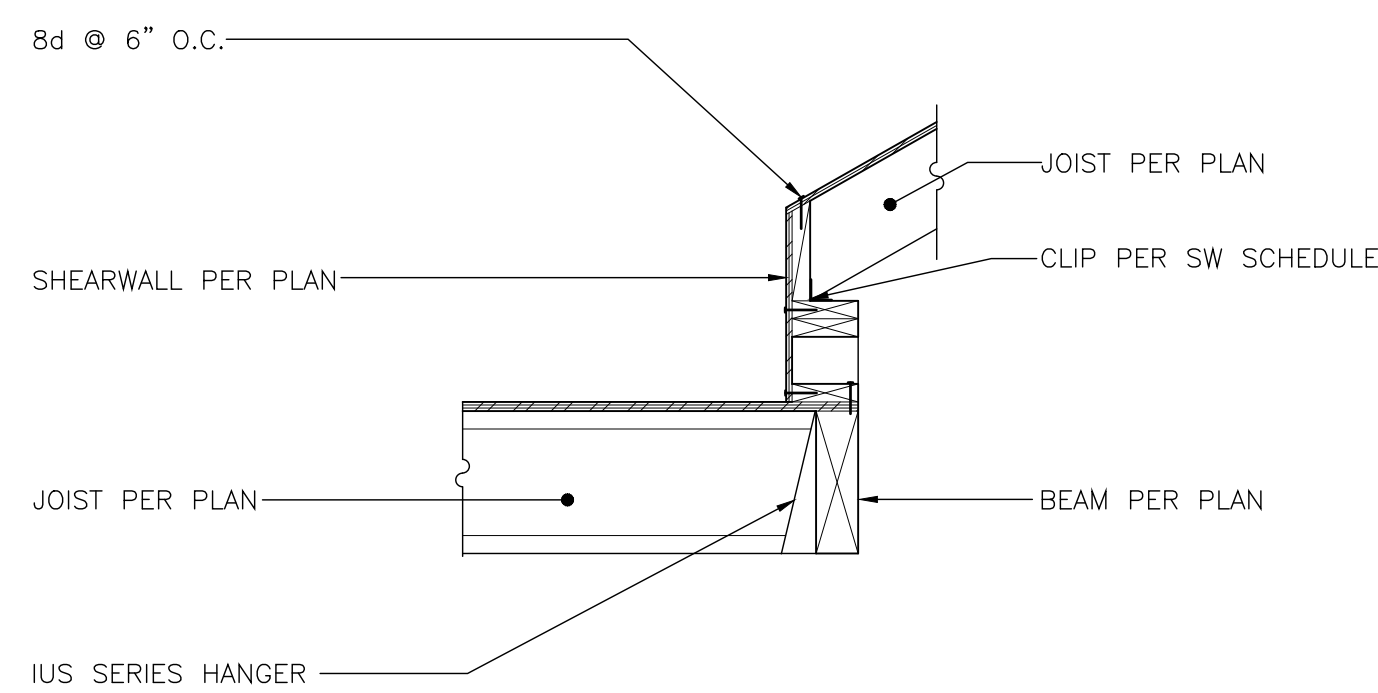

3 Section
scale: 3/4"=1'-0"

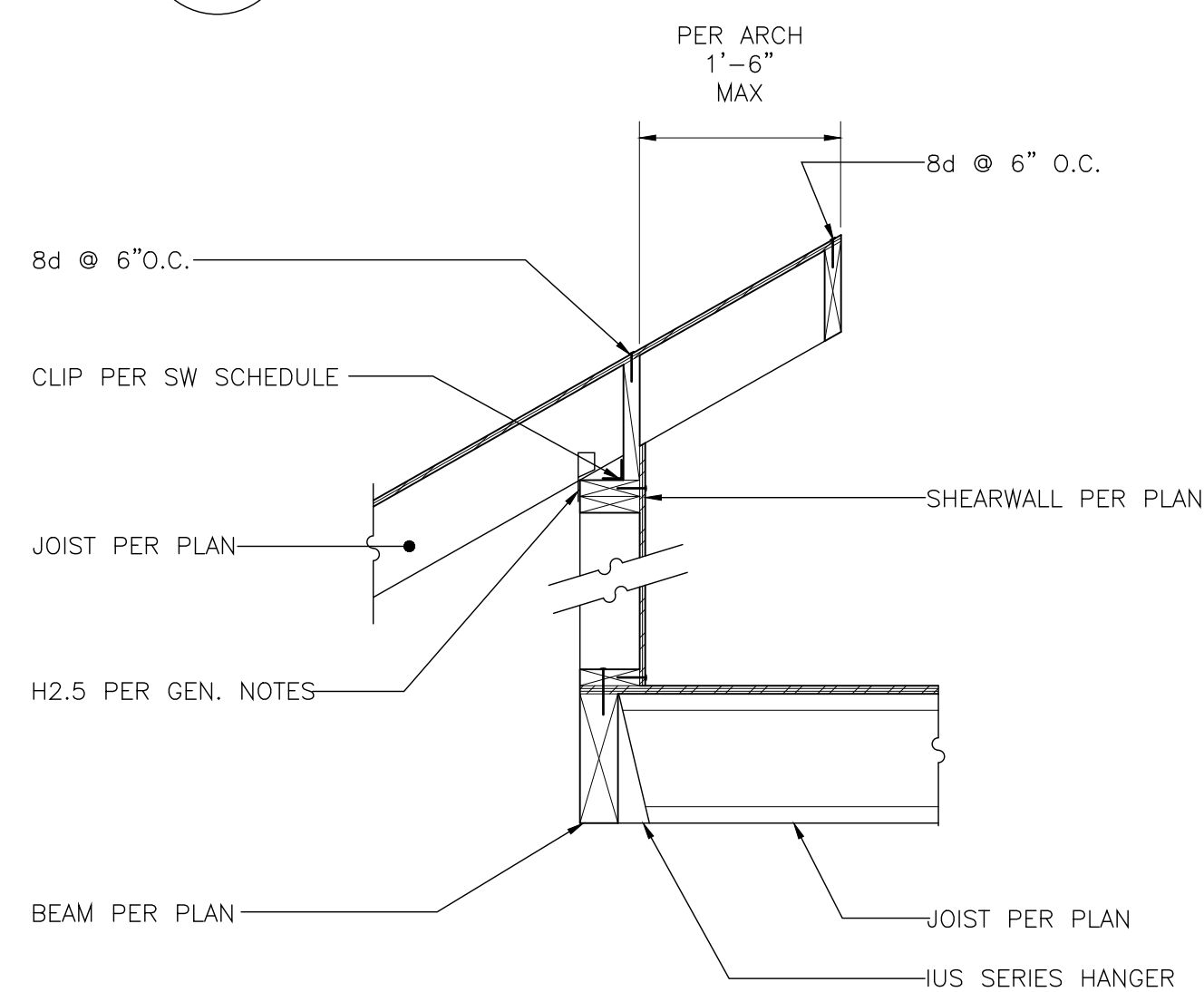

6 Section
scale: 3/4"=1'-0"

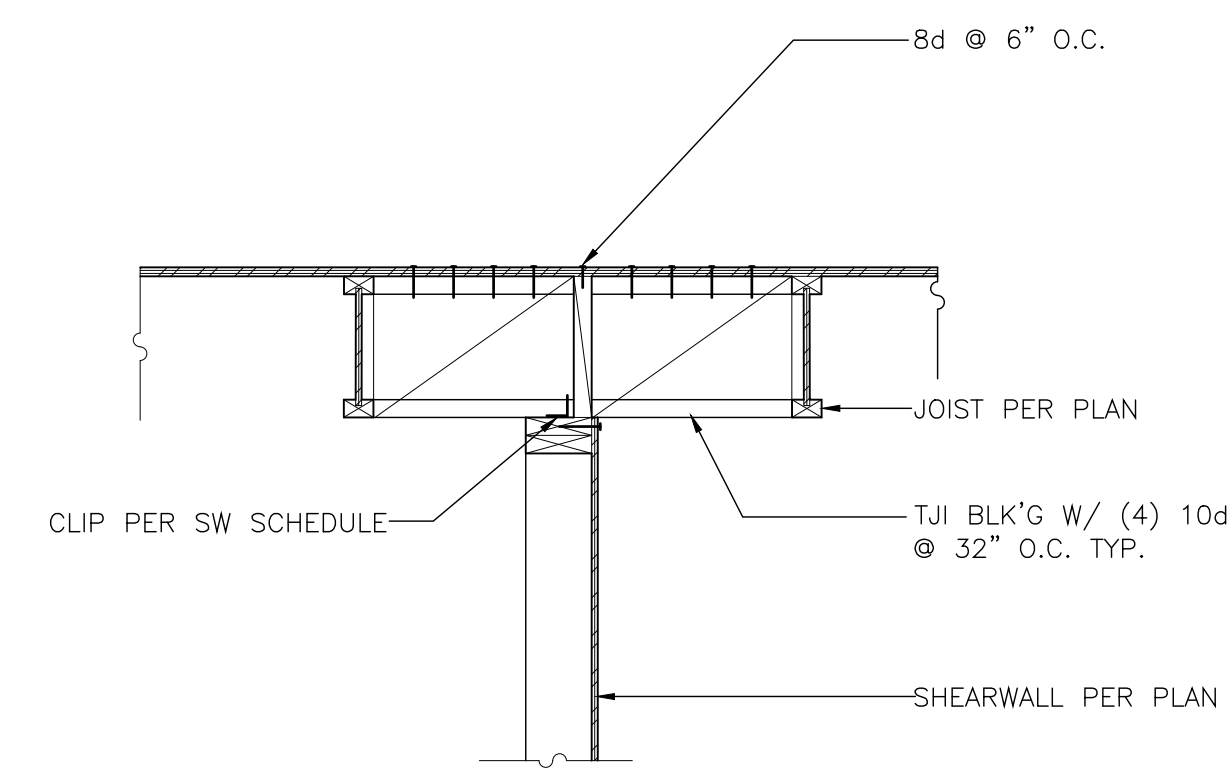

9 Section
scale: 3/4"=1'-0"

12 NOT USED
scale: 3/4"=1'-0"

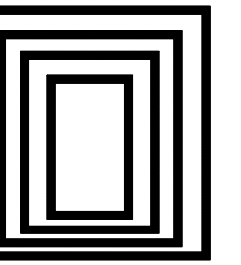

VANEY / SHINDE
New Residence
4207 West Mercer Way
Mercer Island, WA 98040

Date:
5/27/20 Permit Sub
7/15/20 Early Comm Is
8/24/20 FND'N PERMIT
9/8/20 FND'N REVISION
10/30/20
Sub-2 2006-006

Scale:
Sheet:

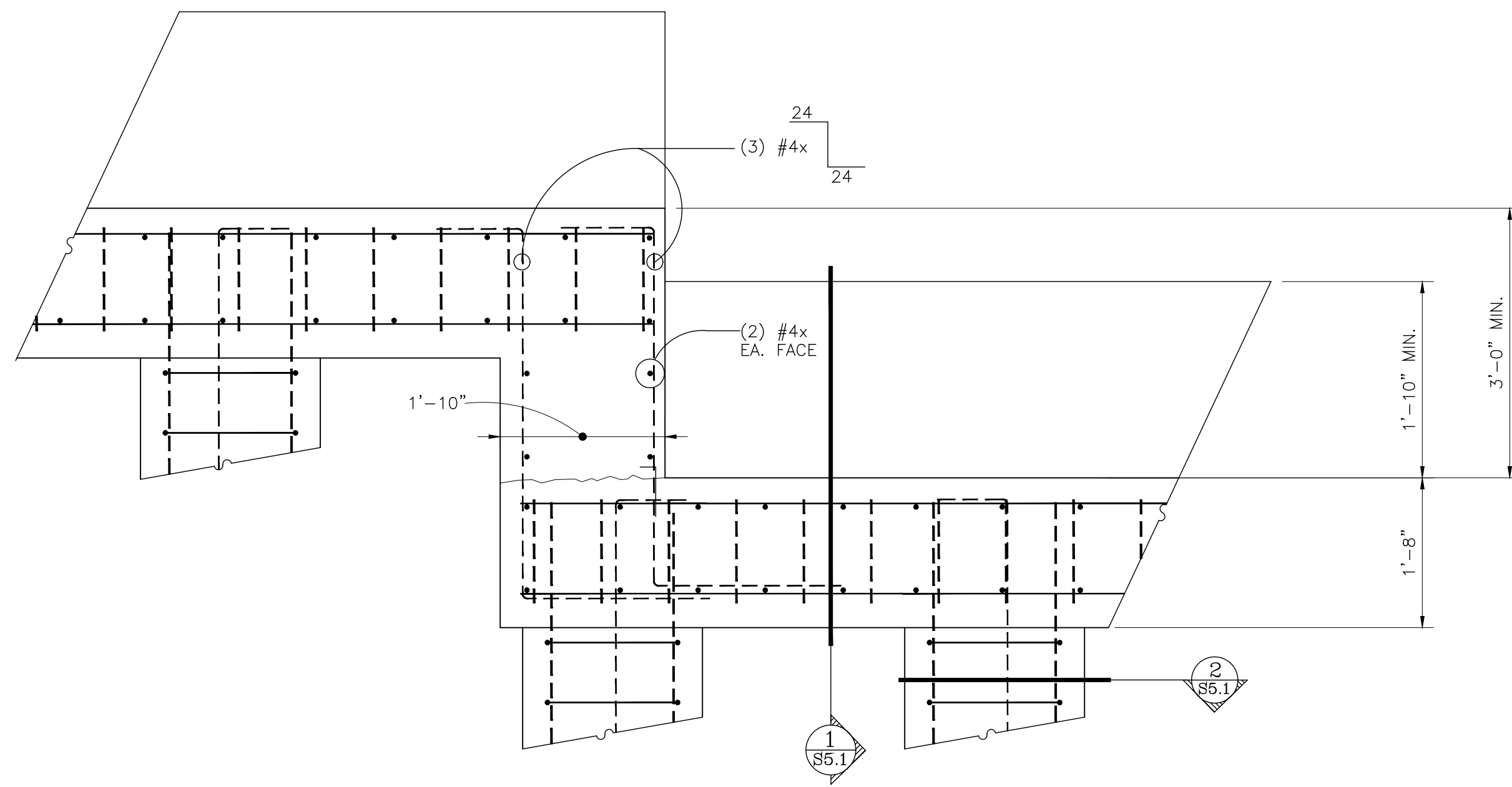
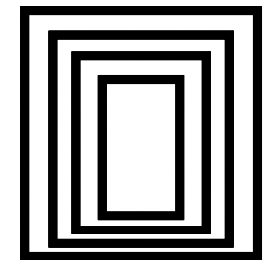

1 Auger Cast Pile Grade Beam Step
scale: 3/4"=1'-0"

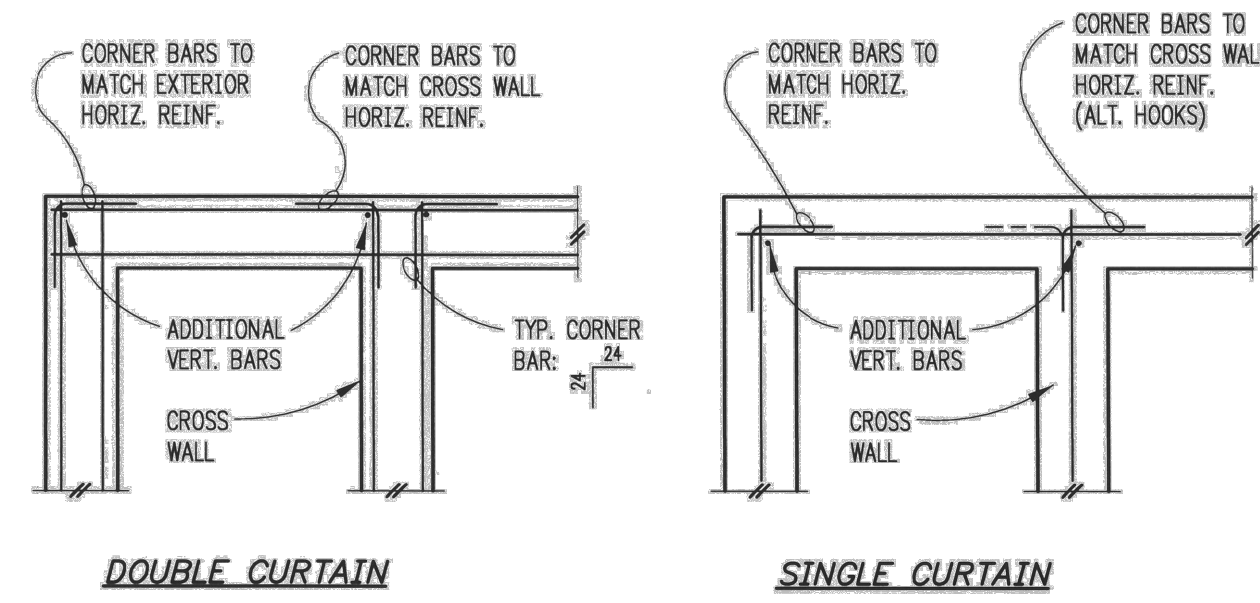

TYPICAL CORNER BARS AT CONCRETE WALLS and grade beams

NOTE: PROVIDE TIES AT GRADE BEAMS PER DETAILS 1/S5.1 AT AUGER PILES AND 5/S5.1 AT PIN-PILES (NOT SHOWN HERE FOR CLARITY)

3 Section
N.T.S.

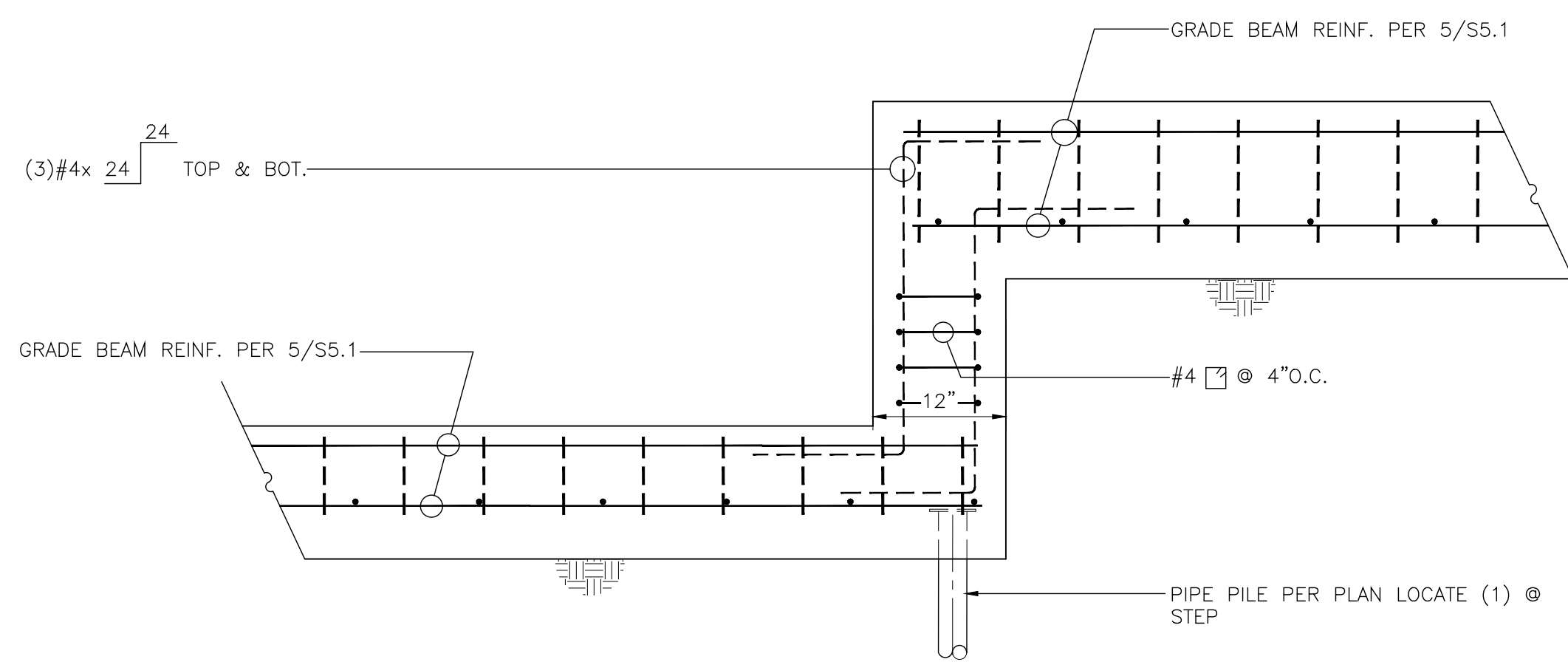

2 Pipe-Pile Grade Beam Step
scale: 3/4"=1'-0"

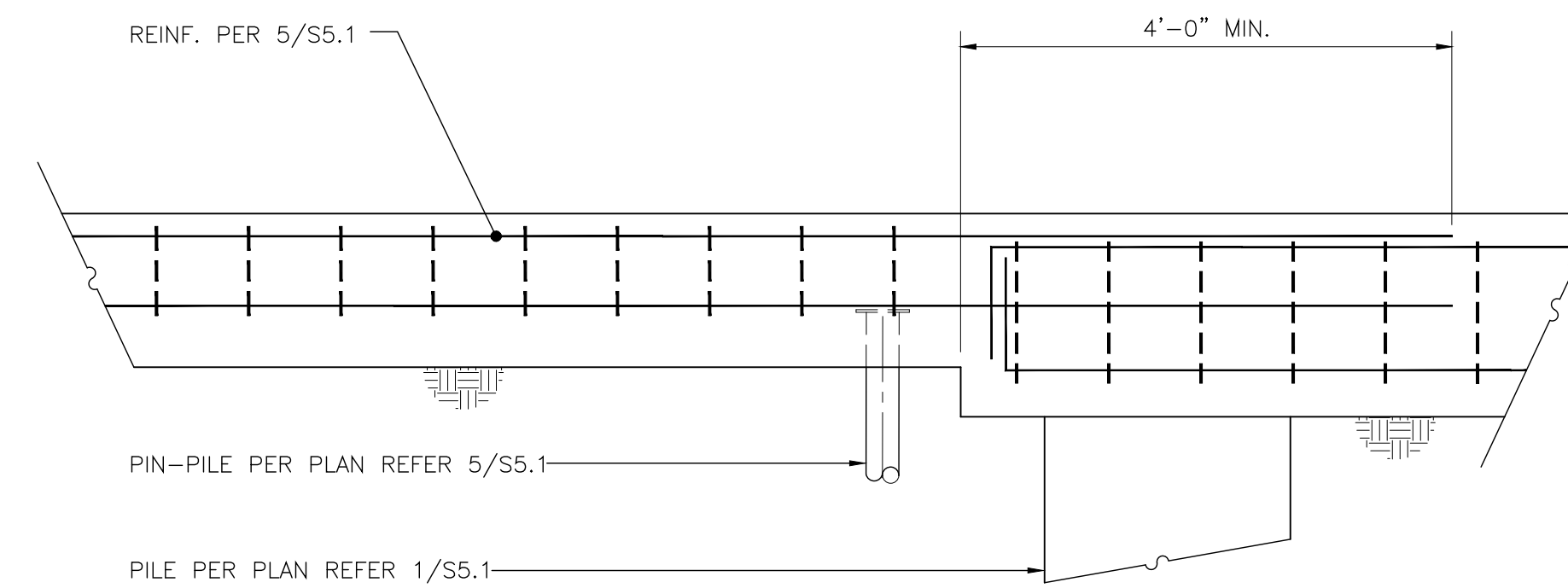

4 Transition Auger Cast Pile to Pin-Pile
scale: 3/4"=1'-0"

VANEY / SHINDE
New Residence
4207 West Mercer Way
Mercer Island, WA 98040

Date:
5/27/20 Permit Sub
7/15/20 Early Comm'ts
8/24/20 FND'N PERMIT
9/8/20 FND'N REVISION
10/30/20
Sub-2 2006-006

Scale:

Sheet:
Structural
Details

S5.5